

Р

ПРИЛОЖЕНИЕ №7

SIEMENS SIPROTEC 5 ЗАЩИТИ 7SJ82/7SJ85 ТЕХНИЧЕСКИ ДАНИИ

OK

№ 1000

Handwritten mark



**SIPROTEC 5
Overcurrent Protection 7SJ82/7SJ85**

V7.30 and higher

Technical Data

Extract from manual C53000-G5040-C017-7, chapter 12

Energy Automation

SIEMENS

Handwritten signature

**NOTE**

For your own safety, observe the warnings and safety instructions contained in this document, if available.

Disclaimer of Liability

This document has been subjected to rigorous technical review before being published. It is revised at regular intervals, and any modifications and amendments are included in the subsequent issues. The content of this document has been compiled for information purposes only. Although Siemens AG has made best efforts to keep the document as precise and up-to-date as possible, Siemens AG shall not assume any liability for defects and damage which result through use of the information contained herein.

This content does not form part of a contract or of business relations; nor does it change these. All obligations of Siemens AG are stated in the relevant contractual agreements.

Siemens AG reserves the right to revise this document from time to time.

Document version: C53000-G5040-C017-7.00

Edition: 07.2016

Version of the product described: V7.30 and higher

Copyright

Copyright © Siemens AG 2016. All rights reserved.

The disclosure, duplication, distribution and editing of this document, or utilization and communication of the content are not permitted, unless authorized in writing. All rights, including rights created by patent grant or registration of a utility model or a design, are reserved.

Registered Trademarks

SIPROTEC®, DIGSI®, SIGUARD®, SIMEAS®, and SICAM® are registered trademarks of Siemens AG. Any unauthorized use is illegal. All other designations in this document can be trademarks whose use by third parties for their own purposes can infringe the rights of the owner.



Preface

Purpose of the Manual

This manual describes the protection, automation, control, and supervision functions of the SIPROTEC 5 device functions for distance protection and line differential protection.

Target Audience

Protection system engineers, commissioning engineers, persons entrusted with the setting, testing and maintenance of automation, selective protection and control equipment, and operational crew in electrical installations and power plants.

Scope

This manual applies to the SIPROTEC 5 device family.

Further Documentation

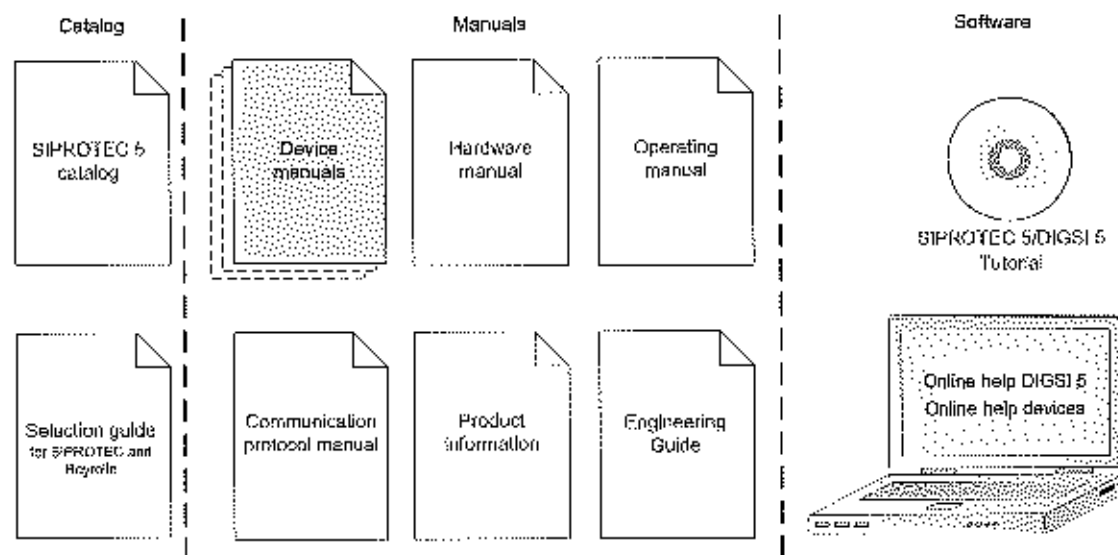

[040218-2016-01-06, 5, w_05]

- **Device manuals**
Each Device manual describes the functions and applications of a specific SIPROTEC 5 device. The printed manual and the online help for the device have the same informational structure.
- **Hardware manual**
The Hardware manual describes the hardware building blocks and device combinations of the SIPROTEC 5 device family.
- **Operating manual**
The Operating manual describes the basic principles and procedures for operating and assembling the devices of the SIPROTEC 5 range.

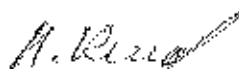
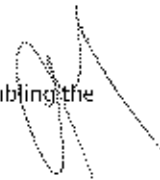

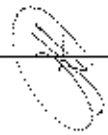

- **Communication protocol manual**
The Communication protocol manual contains a description of the protocols for communication within the SIPROTEC 5 device family and to higher-level network control centers.
- **Product information**
The Product information includes general information about device installation, technical data, limiting values for input and output modules, and conditions when preparing for operation. This document is provided with each SIPROTEC 5 device.
- **Engineering Guide**
The Engineering Guide describes the essential steps when engineering with DIGSI 5. In addition, the Engineering Guide shows you how to load a planned configuration to a SIPROTEC 5 device and update the functionality of the SIPROTEC 5 device.
- **DIGSI 5 online help**
The DIGSI 5 online help contains a help package for DIGSI 5 and CFC.
The help package for DIGSI 5 includes a description of the basic operation of software, the DIGSI principles and editors. The help package for CFC includes an introduction to CFC programming, basic examples of working with CFC, and a reference chapter with all the CFC blocks available for the SIPROTEC 5 range.
- **SIPROTEC 5/DIGSI 5 Tutorial**
The tutorial on the DVD contains brief information about important product features, more detailed information about the individual technical areas, as well as operating sequences with tasks based on practical operation and a brief explanation.
- **SIPROTEC 5 catalog**
The SIPROTEC 5 catalog describes the system features and the devices of SIPROTEC 5.
- **Selection guide for SIPROTEC and Reyrolle**
The selection guide offers an overview of the device series of the Siemens protection devices, and a device selection table.

Indication of Conformity



This product complies with the directive of the Council of the European Communities on harmonization of the laws of the Member States relating to electromagnetic compatibility (EMC Council Directive 2014/30/EU) and concerning electrical equipment for use within specified voltage limits (Low Voltage Directive 2014/35/EU).
This conformity has been proved by tests performed according to the Council Directive in accordance with the product standard EN 60255-26 (for EMC directive) and with the product standard EN 60255-27 (for Low Voltage Directive) by Siemens AG.
The device is designed and manufactured for application in an industrial environment.
The product conforms with the international standards of IEC 60255 and the German standard VDE 0435.

Other Standards

ICCE Std C 37.90
The technical data of the product is approved in accordance with UL.
For more information about the UL database, see www.ul.com
Select Online **Certifications Directory** and enter **E194016** as **UL File Number**.



IND. CONF. EQ.
B9CA

5EJ0002_0001_1

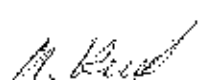

Additional Support

For questions about the system, please contact your Siemens sales partner.

Support

Our Customer Support Center provides a 24-hour service.

Phone: +49 (180) 524-7000
 Fax: +49 (180) 524-2471
 E-Mail: support.energy@siemens.com

Training Courses

Inquiries regarding individual training courses should be addressed to our Training Center:

Siemens AG
 Siemens Power Academy TD

Humboldtstraße 59
 90459 Nürnberg
 Germany

Phone: +49 (911) 433-7415
 Fax: +49 (911) 433-7929
 E-Mail: poweracademy@siemens.com
 Internet: www.siemens.com/poweracademy

Notes on Safety

This document is not a complete index of all safety measures required for operation of the equipment (module or device). However, it comprises important information that must be followed for personal safety, as well as to avoid material damage. Information is highlighted and illustrated as follows according to the degree of danger:



DANGER

DANGER means that death or severe injury will result if the measures specified are not taken.

- ◆ Comply with all instructions, in order to avoid death or severe injuries.



WARNING

WARNING means that death or severe injury may result if the measures specified are not taken.

- ◆ Comply with all instructions, in order to avoid death or severe injuries.



CAUTION

CAUTION means that medium-severe or slight injuries can occur if the specified measures are not taken.

- ◆ Comply with all instructions, in order to avoid moderate or minor injuries.

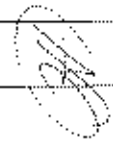

NOTICE

NOTICE means that property damage can result if the measures specified are not taken.

- ◆ Comply with all instructions, in order to avoid property damage.



NOTE

Important information about the product, product handling or a certain section of the documentation which must be given particular attention.

Qualified Electrical Engineering Personnel

Only qualified electrical engineering personnel may commission and operate the equipment (module, device) described in this document. Qualified electrical engineering personnel in the sense of this manual are people who can demonstrate technical qualifications as electrical technicians. These persons may commission, isolate, ground and label devices, systems and circuits according to the standards of safety engineering.

Proper Use

The equipment (device, module) may be used only for such applications as set out in the catalogs and the technical description, and only in combination with third-party equipment recommended and approved by Siemens.

Problem-free and safe operation of the product depends on the following:

- Proper transport
- Proper storage, setup and installation
- Proper operation and maintenance

When electrical equipment is operated, hazardous voltages are inevitably present in certain parts. If proper action is not taken, death, severe injury or property damage can result:

- The equipment must be grounded at the grounding terminal before any connections are made.
- All circuit components connected to the power supply may be subject to dangerous voltage.
- Hazardous voltages may be present in equipment even after the supply voltage has been disconnected (capacitors can still be charged).
- Operation of equipment with exposed current-transformer circuits is prohibited. Before disconnecting the equipment, ensure that the current-transformer circuits are short-circuited.
- The limiting values stated in the document must not be exceeded. This must also be considered during testing and commissioning.

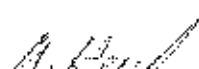

12 Technical Data

12.1	General Device Data	1329
12.2	Protection Interface and Protection Topology	1338
12.3	Date and Time Synchronization	1340
12.4	Analog Units Function Group	1341
12.5	Overcurrent Protection, Phases	1342
12.6	Voltage-Dependent Overcurrent Protection, Phases	1354
12.7	Overcurrent Protection, Ground	1357
12.8	Directional Overcurrent Protection, Phases	1367
12.9	Directional Overcurrent Protection, Ground	1373
12.10	Inrush-Current Detection	1383
12.11	Arc Protection	1384
12.12	Instantaneous High-Current Tripping	1385
12.13	Instantaneous Tripping at Switch onto Fault	1386
12.14	Overcurrent Protection, 1-Phase	1387
12.15	Overcurrent Protection, 1-Phase (Fast Stage)	1392
12.16	Non-Directional Intermittent Ground-Fault Protection	1393
12.17	Directional Intermittent Ground-Fault Protection	1395
12.18	Sensitive Ground-Fault Detection	1397
12.19	Undercurrent Protection	1405
12.20	Negative-Sequence Protection	1407
12.21	Directional Negative-Sequence Protection with Definite-Time Delay	1411
12.22	Thermal Overload Protection, 3-Phase	1413
12.23	Thermal Overload Protection, User-Defined Characteristic Curve	1416
12.24	Unbalanced-Load Protection	1417
12.25	Current-Unbalance Protection for Capacitors, 3-Phase	1419
12.26	Current-Unbalance Protection for Capacitors, 1-Phase	1421
12.27	Voltage-Differential Protection for Capacitor Banks	1423
12.28	Differential Protection for Capacitor Banks	1424
12.29	Overvoltage Protection with 3-Phase Voltage	1426
12.30	Overvoltage Protection with Zero-Sequence Voltage/Residual Voltage	1428
12.31	Overvoltage Protection with Positive-Sequence Voltage	1430
12.32	Overvoltage Protection with Negative-Sequence Voltage	1431
12.33	Overvoltage Protection with Any Voltage	1432
12.34	Peak Overvoltage Protection for Capacitors	1434



12.35	Overvoltage Protection with Negative-Sequence Voltage/Positive-Sequence Voltage	1436
12.36	Undervoltage Protection with 3-Phase Voltage	1437
12.37	Undervoltage Protection with Positive-Sequence Voltage	1440
12.38	Undervoltage Protection with Any Voltage	1442
12.39	Overfrequency Protection	1443
12.40	Underfrequency Protection	1444
12.41	Rate of Frequency Change Protection	1445
12.42	3-Phase Power Protection (P,Q)	1446
12.43	Reverse-Power Protection	1447
12.44	Overexcitation Protection	1448
12.45	Undervoltage-Controlled Reactive-Power Protection	1450
12.46	Circuit-Breaker Failure Protection	1452
12.47	Circuit-Breaker Restrike Protection	1454
12.48	Restricted Ground-Fault Protection	1455
12.49	External Trip Initiation	1457
12.50	Automatic Reclosing	1458
12.51	Fault Locator	1459
12.52	Temperature Supervision	1460
12.53	Current-Jump Detection	1461
12.54	Voltage-Jump Detection	1462
12.55	Synchronization Function	1463
12.56	Voltage Controller	1465
12.57	Current-Balance Supervision	1468
12.58	Voltage-Balance Supervision	1469
12.59	Current-Sum Supervision	1470
12.60	Voltage-Sum Supervision	1471
12.61	Current Phase-Rotation Supervision	1472
12.62	Voltage Phase-Rotation Reversal	1473
12.63	Trip-Circuit Supervision	1474
12.64	Analog Channel Supervision via Fast Current Sum	1475
12.65	Measuring Voltage Failure Detection	1476
12.66	Voltage-Transformer Circuit Breaker	1478
12.67	Operational Measured Values and Statistical Values	1479
12.68	Energy Values	1483
12.69	Phasor Measurement Unit	1484
12.70	Circuit-Breaker Wear Monitoring	1485
12.71	CFC	1486

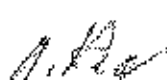

12.1 General Device Data

12.1.1 Analog Inputs

Current Inputs

All current, voltage, and power data are specified as RMS values.			
Rated frequency f_{rated}	50 Hz, 60 Hz		
Protection-class current transformers	Rated current I_{rated}	Measuring range of the modular devices	Measuring range of the non-modular devices
	5 A	0 A to 500 A	0 A to 250 A
	1 A	0 A to 100 A	0 A to 50 A
Instrument transformers	5 A	0 A to 8 A	0 A to 8 A
	1 A	0 A to 1.6 A	0 A to 1.6 A
Power consumption per current circuit at rated current	Approx. 0.3 VA		
Thermal rating (protection and instrument transformers)	500 A for 1 s		
	150 A for 10 s		
	20 A continuously		
	25 A for 3 min		
	30 A for 2 min		
Dynamic load-carrying capacity	1250 A one half wave		

Voltage Input

All current, voltage, and power data are specified as RMS values.		
Rated frequency f_{rated}	50 Hz, 60 Hz	
Input and output modules	IO202/IO208/IO211/IO214	IO215
Measuring range	0 V to 200 V	0 V to 7.07 V
Input impedance	< 0.1 VA	< 0.01 VA
Thermal rating	230 V continuously	20 V continuously

Measuring-Transducer Inputs (via Module ANAI-CA-4EL)

Connector type	8-pin multiple contact strip
Differential current input channels	4
Measuring range	DC -24 mA to +24 mA
Fault	< 0.5 % of measuring range
Input impedance	140 Ω
Conversion principle	Delta-sigma (16 bit)
Permissible potential difference between channels	DC 20 V
Galvanic separation from ground/housing	DC 700 V
Permissible overload	DC 100 mA continuously
Measurement repetition	200 ms

Measuring-Transducer Inputs (via Module ARC-CD-3FO)

Connector type	AVAGO AFBR-4526Z
Number of transceivers	3

Fiber type	Polymer Optical Fiber (POF) 1 mm
Receiver	
Maximum	-10 dBm ± 2 dBm
Minimum	-40 dBm + 2 dBm
Spectrum	400 nm to 1100 nm
Attenuation	In the case of plastic optical fibers, you can expect a path attenuation of 0.2 dB/m. Additional attenuation comes from the plug and sensor head.
Optical budget ¹	Minimal 25 dB
Analog sampling rate	16 kHz
ADC type	10-bit successive approximation
Transmitter	
Type	LED
Wavelength	$\lambda = 650 \text{ nm}$
Transmit power	Minimum 0 dBm Maximum 2 dBm
Numerical aperture	0.5 ²
Signal rate connection test	1 pulse per second
Pulse duration connection test	11 μs
Comment:	
¹ All values in combination with sensors approved by Siemens.	
² Numerical aperture (NA = $\sin \theta$ (launch angle))	

High-Speed Measuring-Transducer Inputs, Voltage/Current (via IO210, IO212)



NOTE

Current and voltage may not be connected to a measuring-transducer input at the same time; only either current or voltage may be connected. Due to EMC, no line may be connected to an input that is not used (current or voltage).
Use shielded cables.

Table 12-1 High-Speed Measuring-Transducer Inputs, Voltage

Differential voltage input channels	8 ²⁷
Measuring range	DC -10 V to +10 V
Fault	< 0.5 % of the measuring range
Input impedance	48 k Ω
Conversion principle	Delta-sigma (16 bit)
Permissible potential difference between channels	DC 3.5 kV
Galvanic separation from ground/housing	DC 3.5 kV
Permissible overload	DC 20 V continuously DC 60 V continuously (IO210 MT3 terminal point C9)
Measurement repetition	62.5 μs

Table 12-2 High-Speed Measuring-Transducer Inputs, Current

Differential current input channels	8 ²⁸
-------------------------------------	-----------------

²⁷ The IO212 has 8 high-speed measuring-transducer inputs. They can be used either as a voltage or as a current input.

²⁸ The IO212 has 8 high speed measuring-transducer inputs. They can be used either as a voltage or as a current input.

A. Reu

M

Measuring range	DC 20 mA to 120 mA
Fault	< 0.5 % of the measuring range
Input impedance, current	12 Ω
Conversion principle	Delta-sigma (16 bit)
Permissible potential difference between channels	DC 3.5 kV
Galvanic separation from ground/ housing	DC 3.5 kV
Permissible current overload	DC 100 mA continuously
Measurement repetition	62.5 μ s

12.1.2 Supply Voltage

Integrated Power Supply			
For modular devices, the following printed circuit-board assemblies have a power supply: PS201 – Power supply of the base module and of the 1st device row PS203 – Voltage supply of 2nd device row CB202 – Plug in module assembly with integrated power supply, for example, to accommodate communication modules			
Permissible voltage ranges (PS201, PS203, CB202)	DC 19 V to DC 60 V	DC 48 V to DC 300 V AC 80 V to AC 265 V, 50 Hz/60 Hz	
Auxiliary rated voltage V_H (PS201, PS203, CB202)	DC 24 V/DC 48 V	DC 60 V/DC 110 V/DC 125 V/DC 220 V DC 250 V or AC 100 V/AC 115 V/AC 230 V, 50 Hz/60 Hz	
Permissible voltage ranges (PS101)	DC 19 V to DC 60 V	DC 48 V to 150 V	DC 88 V to DC 300 V AC 80 V to AC 265 V, 50 Hz/60 Hz
Auxiliary rated voltage V_H (PS101)	DC 24 V/DC 48 V	DC 60 V/DC 110 V/DC 125 V	DC 110 V/DC 125 V/DC 220 V/DC 250 V or AC 100 V/AC 115 V/AC 230 V, 50 Hz/60 Hz
Superimposed alternating voltage, peak-to-peak, IEC 60255-11	\pm 15% of the DC auxiliary rated voltage (applies only to direct voltage)		
Inrush current	< 18 A		
Recommended external protection	Miniature circuit breaker 6 A, characteristic C according to IEC 60898		
Internal fuse			
	DC 24 V to DC 48 V	DC 60 V to DC 125 V	DC 24 V to DC 48 V AC 100 V to AC 230 V
PS101	4 A interL, AC 250 V, DC 150 V, UL recognized SIBA type 179200 or Schurter type SPT 5x20	2 A time-lag, AC 250 V, DC 300 V, UL recognized SIBA type 179200 or Schurter type SPT 5x20	
PS201, PS203, CB202	2 A time-lag, AC 250 V, DC 300 V, UL recognized SIBA type 179200 or Schurter type SPT 5x20		
Power consumption (life relay active)			
–	DC	AC 230 V/50 Hz	AC 115 V/50 Hz

Integrated Power Supply			
1/3 base module, non-modular Without plug-in modules	7.0 W	16 VA	12.5 VA
1/3 base module, modular Without plug-in modules	13 W	33 VA	24 VA
1/6 expansion module	3 W	6 VA	6 VA
1/6 plug-in module assembly without plug in modules (modules CB202)	3.5 W	14 VA	7 VA
Plug-in module for base module or plug in module assembly (for example, communication module)	< 5 W	< 6 VA	< 6 VA
Stored-energy time for auxiliary voltage outage or short circuit, modular devices	For V ≥ DC 24 V ≥ 50 ms For V ≥ DC 110 V ≥ 50 ms For V ≥ AC 115 V ≥ 50 ms		
Stored-energy time for auxiliary voltage outage or short circuit, non-modular devices	For V ≥ DC 24 V ≥ 20 ms For V ≥ DC 60 V/DC 110 V ≥ 50 ms For V ≥ AC 115 V ≥ 200 ms		

12.1.3 Binary Inputs

Rated voltage range	DC 24 V to 250 V The binary inputs of SIPROTEC 5 are bipolar with the exception of the binary inputs on the IO230 and on the IO231.	
Current consumption, excited	Approx. DC 0.6 mA to 1.8 mA (independent of the operating voltage)	
Power consumption, max.	0.6 VA	
Pickup time	Approx. 3 ms	
Dropout time	Approx. 4 ms	
Switching thresholds	Adjustable with DIGSI 5	
	Range 1 for 24 V, 48 V, and 60 V Operating voltage	$V_{low} \leq DC 10 V$ $V_{high} \geq DC 19 V$
	Range 2 for 110 V and 125 V Operating voltage	$V_{low} < DC 44 V$ $V_{high} \geq DC 88 V$
	Range 3 for 220 V and 250 V Operating voltage	$V_{low} \leq DC 88 V$ $V_{high} \geq DC 176 V$
Maximum permitted voltage	DC 300 V	
The binary inputs contain interference suppression capacitors. In order to ensure EMC, use the terminals shown in the terminal diagrams/connection diagrams to connect the binary inputs to the common potential.		

12.1.4 Relay Outputs

Standard Relay (Type S)

Switching capacity	On: 1000 W/VA Off: 30 VA; 40 W ohmic; 30 W/VA at L/R ≤ 40 ms
AC and DC contact voltage	250 V

Permissible current per contact (continuous)	5 A
Permissible current per contact (switching on and holding)	30 A for 1 s (make contact)
Short-time current across closed contact	250 A for 30 ms
Total permissible current for contacts connected to common potential	5 A
Switching time OOT (Output Operating Time) Additional delay of the output medium used	≤ 10 ms, typically 8 ms
Max. rated data of the output contacts in accordance with UL certification	DC 24 V, 8 A, General Purpose DC 48 V, 0.8 A, General Purpose DC 240 V, 0.1 A, General Purpose AC 240 V, 5 A, General Purpose AC 120 V, 1/3 hp AC 250 V, 1/2 hp B300 R300
Interference suppression capacitors across the contacts	4.7 nF, ± 20 %, AC 250 V

Fast Relay (Type F)

Switching capacity	On: 1000 W/VA Off: 30 VA; 40 W ohmic; 30 W/VA at LIR ≤ 40 ms
AC and DC contact voltage	250 V
Permissible current per contact (continuous)	5 A
Permissible current per contact (switching on and holding)	30 A for 1 s (make contact)
Short-time current across closed contact	250 A for 30 ms
Total permissible current for contacts connected to common potential	5 A
Switching time OOT (Output Operating Time) Additional delay of the output medium used	Closing time, typical: 4 ms Opening time, typical: 2 ms ≤ 5 ms
Rated data of the output contacts in accordance with UL certification	AC 120 V, 8.5 A, General Purpose AC 277 V, 6 A, General Purpose AC 277 V, 0.7 hp AC 347 V, 4.5 A, General Purpose B300 R300
Interference suppression capacitors across the contacts	4.7 nF, ± 20 %, AC 250 V
Supervision	2-channel activation with cyclic testing (only for make contact)

High-Speed Relay with Semiconductor Acceleration (Type HS)

Switching capacity	On/Off: 1000 W/VA
Contact voltage	AC 200 V, DC 250 V
Permissible current per contact (continuous)	5 A

Permissible current per contact (switching on and holding)	30 A for 1 s (make contact)
Short-time current across closed contact	250 A for 30 ms
Total permissible current for contacts connected to common potential	5 A
Switching time OOT (Output Operating Time) Additional delay of the output medium used	Closing time, typical: 0.2 ms Opening time, typical: 6 ms Maximum: ≤ 9 ms
Rated data of the output contacts in accordance with UL certification:	B150 Q300

Power Relay (for Direct Control of Motor Switches)

Switching capacity for permanent and periodic operation		
250 V/4.0 A	1000 W	In order to prevent any damage, the external protection circuit must switch off the motor in case the rotor is blocked.
220 V/4.5 A	1000 W	
110 V/5.0 A	550 W	
60 V/5.0 A	300 W	
48 V/5.0 A	240 W	
24 V/5.0 A	120 W	
Turn on switching power for 30 s, recovery time until switching on again is 15 minutes. For short-term switching operations, an impulse/pause ratio of 3 % must be considered.		
100 V/9.0 A	1000 W	Continuous and inching operation is not permitted. In order to prevent any damage, the external protection circuit must switch off the motor in case the rotor is blocked.
60 V/10.0 A	600 W	
48 V/10.0 A	480 W	
24 V/10.0 A	240 W	
AC and DC contact voltage		250 V
Permissible continuous current per contact		5 A
Permissible current per contact (switching on and holding)		30 A for 1 s
Short-time current across closed contact		250 A for 30 ms
Total permissible current for contacts connected to common potential		5 A
Switching time OOT (Output Operating Time) Additional delay of the output medium used		≤ 16 ms
Rated data of the output contacts in accordance with UL certification		DC 300 V, 10 A, Resistive DC 250 V, 1 hp motor - 30 s ON, 15 min OFF DC 110 V, 3/4 hp motor - 30 s ON, 15 min OFF DC 60 V, 1/2 hp motor - 30 s ON, 15 min OFF DC 48 V, 1/3 hp motor - 30 s ON, 15 min OFF DC 24 V, 1/6 hp motor - 30 s ON, 15 min OFF
Interference suppression capacitors across the contacts		4.7 nF, ± 20 %, AC 250 V
The power relays operate in interlocked mode, that is, only one relay of each switching pair picks up at a time thereby avoiding a power-supply short circuit.		

12.1.5 Design Data

Masses

Type of construction	Device Size Weight of the Modular Devices				
	1/3	1/2	2/3	5/6	1/1
Flush-mounting device	4.8 kg	8.1 kg	11.4 kg	14.7 kg	18.0 kg
Surface-mounted device with integrated on-site operation panel	7.8 kg	12.6 kg	17.4 kg	22.2 kg	27.0 kg
Surface-mounted device with detached on-site operation panel	5.1 kg	8.7 kg	12.3 kg	15.9 kg	19.5 kg

	Size	Weight
Detached on-site operation panel	1/3	1.9 kg
Detached on-site operation panel	1/6	1.1 kg

Type of construction	Device Size Weight of the Non-Modular Devices 7xx82
	Flush-mounting device
Bracket for non-modular surface-mounting variant	1.9 kg

Dimensions of the Basic and 1/3 Modules

Type of Construction (Maximum Dimensions)	Width over all x Height over all x Depth ²⁹ (in Inches)
Flush-mounting device	150 mm x 268 mm x 229 mm (5.91 x 10.55 x 9.02)
Surface-mounted device with integrated on-site operation panel	150 mm x 314 mm x 337 mm (5.91 x 12.36 x 13.27)
Surface-mounted device with detached on-site operation panel	150 mm x 314 mm x 230 mm (5.91 x 12.36 x 9.06)

Dimensions of Device Rows

Type of Construction (Maximum Dimensions)	Width over all x Height over all x Depth ³⁰ (in Inches)				
	1/3	1/2	2/3	5/6	1/1
Flush-mounting device	150 mm x 268 mm x 229 mm (5.91 x 10.55 x 9.02)	225 mm x 268 mm x 229 mm (8.86 x 10.55 x 9.02)	300 mm x 268 mm x 229 mm (11.81 x 10.55 x 9.02)	375 mm x 268 mm x 229 mm (14.76 x 10.55 x 9.02)	450 mm x 268 mm x 229 mm (17.72 x 10.55 x 9.02)
Surface-mounted device with integrated on-site operation panel	150 mm x 314 mm x 337 mm (5.91 x 12.36 x 13.27)	225 mm x 314 mm x 337 mm (8.86 x 12.36 x 13.27)	300 mm x 314 mm x 337 mm (11.81 x 12.36 x 13.27)	375 mm x 314 mm x 337 mm (14.76 x 12.36 x 13.27)	450 mm x 314 mm x 337 mm (17.72 x 12.36 x 13.27)

²⁹ Width and depth rounded to whole numbers in mm

³⁰ Width and depth rounded to whole numbers in mm

Type of Construction (Maximum Dimensions)	Width over all x Height over all x Depth ³⁰ (in Inches)				
	Surface mounted device with detached on-site operation panel	150 mm x 314 mm x 230 mm (5.91 x 12.36 x 9.06)	225 mm x 314 mm x 230 mm (8.86 x 12.36 x 9.06)	300 mm x 314 mm x 230 mm (11.81 x 12.36 x 9.06)	375 mm x 314 mm x 230 mm (14.76 x 12.36 x 9.06)

Expansion Module Dimensions

Type of Construction (Maximum Dimensions)	Width x Height x Depth ³¹ (in Inches)
Flush-mounting device	75 mm x 268 mm x 229 mm (2.95 x 10.55 x 9.02)
Surface-mounted device with integrated on-site operation panel	75 mm x 314 mm x 337 mm (2.95 x 12.36 x 13.27)
Surface-mounted device with detached on-site operation panel	75 mm x 314 mm x 230 mm (2.95 x 12.36 x 9.06)

Plug-In Module Dimensions

Type of Construction (Maximum Dimensions)	Width x Height x Depth (in Inches)
USART-Ax-xEL, ETH-Bx-xEL	61 mm x 45 mm x 120,5 mm (2.4 x 1.77 x 4.74)
USART-Ax-xFO, ETH-Bx-xFO (without protection cover)	61 mm x 45 mm x 132,5 mm (2.4 x 1.77 x 5.22)
ANAL-CA-4EL	61 mm x 45 mm x 119,5 mm (2.4 x 1.77 x 4.7)
ARC-CD-3FO	61 mm x 45 mm x 120,5 mm (2.4 x 1.77 x 4.74)

Minimum Bending Radii of the Connecting Cables Between the On-Site Operation Panel and the Base Module

Fiber-optic cable	R = 50 mm Pay attention to the length of the cable protection sleeve, which you must also include in calculations.
D-Sub cable	R = 50 mm (minimum bending radius)

Degree of Protection to IEC 60529

For equipment in the surface-mounting housing	IP50
For equipment in the flush-mounting housing	Front IP51 Back side of the modular devices IP50 Back side of the non-modular devices IP40
For operator protection	IP2x for current terminal (installed/removed) IP1x for voltage terminal (removed/without cover) IP2x for voltage terminal (removed/with cover) IP7x for voltage terminal (installed)
Degree of pollution, IEC 60255-27	2
Maximum altitude above sea level	2000 m (6561.68 ft)

³⁰ Width and depth rounded to whole numbers in mm

³¹ Width and depth rounded to whole numbers in mm

A. Beck

M

UL Note

Type 1 if mounted into a door or front cover of an enclosure.
When expanding the device with the 2nd device row, then they must be mounted completely inside an enclosure.

Tightening Torques for Terminal Screws

Type of Line	Current Terminal	Voltage Terminal with Spring-Loaded Terminals	Voltage Terminal with Screw Connection
Litz wire with ring-type lug	2.7 Nm	No ring-type lug	No ring-type lug
Stranded wires with boot-lace ferrules or pin-type lugs	2.7 Nm	1.0 Nm	0.6 Nm
Solid conductor, bare (2 mm ²)	2.0 Nm	1.0 Nm	-



NOTE

Use copper cables only.

Torques for Other Screw Types

Screw Type	Torque
M4 x 20	1.2 Nm
M4 x 8	1.2 Nm
M2.5 x 6	0.39 Nm
Countersunk screw, M2.5 x 6	0.39 Nm
Countersunk screw, M2.5 x 8	0.39 Nm
Collar screw, M4 x 20	0.7 Nm

A. R. [Signature]

[Handwritten mark]

12.2 Protection Interface and Protection Topology



Setting Values

Mode	On Off	
PPS Synchronization	Telegr. and PPS Telegr. or PPS PPS synchronization off	
Blocking of the unbalanced runtimes	Yes No	
Maximum signal runtime threshold	0.1 ms to 30.0 ms	Increments of 0.1 ms
Maximum runtime difference	0.000 ms to 3.000 ms	Increments of 0.001 ms
Failure indication after	0.05 s to 2.00 s	Increments of 0.01 s
Failure indication after	0.0 s to 6.0 s	Increments of 0.1 s
Max. error rate/h	0.000 % to 100.000 %	Increments of 0.001 %
Max. error rate/min	0.000 % to 100.000 %	Increments of 0.001 %
PPS failure indication after	0.5 s to 60.0 s	Increments of 0.1 s

Transmission Rate

Direct connection:	
Transmission rate	2048 kbit/s
Connection via communication networks:	
Supported network interfaces	G703.1 with 64 kBit/s G703-T1 with 1.455 MBit/s G703-E1 with 2.048 MBit/s X.21 with 64 kbit/s or 128 kbit/s or 512 kbit/s Pilot wires with 128 kbit/s
Transmission rate	64 kBit/s at G703.1 1.455 MBit/s at G703-T1 2.048 MBit/s at G703-E1 512 kbit/s or 128 kbit/s or 64 kbit/s at X.21 128 kbit/s for pilot wires

Transmission Times

Priority 1		
Response time, total approx.		
For 2 ends	Minimum	8 ms
	Typical	10 ms
For 3 ends	Minimum	10 ms
	Typical	14 ms
For 6 ends	Minimum	15 ms
	Typical	18 ms
Dropout times, total approx.		
For 2 ends	Typical	20 ms
For 3 ends	Typical	20 ms
For 6 ends	Typical	26 ms



A. D. ...

Priority 2		
Response time, total approx.		
For 2 ends	Minimum	9 ms
	Typical	16 ms
For 3 ends	Minimum	12 ms
	Typical	18 ms
For 6 ends	Minimum	17 ms
	Typical	23 ms
Dropout times, total approx.		
For 2 ends	Typical	24 ms
For 3 ends	Typical	25 ms
For 6 ends	Typical	32 ms
Priority 3³²		
Response time, total approx.		
For 2 ends	Minimum	
	Typical	100 ms
For 3 ends	Minimum	
	Typical	150 ms
For 6 ends	Minimum	
	Typical	200 ms
Dropout times, total approx.		
For 2 ends	Typical	100 ms
For 3 ends	Typical	150 ms
For 6 ends	Typical	200 ms

³²Times cannot be determined because the signals are transmitted in fragments.



12.3 Date and Time Synchronization

Date format	DD.MM.YYYY (Europe)
	MM/DD/YYYY (USA)
	YYYY-MM-DD (China)
Time source 1, time source 2	None
	IRIG-B 002(003)
	IRIG-B 006(007)
	IRIG-B 005(004) with extension according to IEEE C37.118-2005
	DCF77
	PI (protection interface) ²³
	SNTP
	IEC 60870-5-103
	DNP3
IEEE 1588	
Time zone 1, time zone 2	Local
	UTC
Failure indication after	0 s to 3600 s
Time zone and daylight saving time	Transfer of PC settings
	Manually setting the time zones
Time zone offset with respect to GMT	-720 min to 840 min
Switching over to daylight saving time	Active
	Inactive
Beginning of daylight saving time	Input: day and time
End of daylight saving time	Input: day and time
Offset daylight saving time	-120 to 120 [steps of 15]

²³ If provided

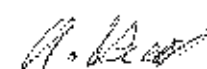

12.4 Analog-Units Function Group

20-mA Unit Ether. 7XV5674-DKK00-1AA1

Max. number of connected 20-mA units	4
Max. number of channels per 20-mA unit	12

20-mA Unit Serial 7XV5674-DKK30-1AA1 (RS485) and 7XV5674-DKK40-1AA1 (fiberglass)

Max. number of connected 20-mA units	4
Max. number of channels per 20-mA unit	12

RTD Unit (Ziehl TR1200) 7XV5662-6AD10

Max. number of connected RTD units	4
Max. number of sensors per RTD unit	12
Sensor type	Pl 100 as per EN 60751

RTD Unit (Ziehl TR1200 IP) 7XV5662-8AD10

Max. number of connected RTD units	4
Max. number of sensors per RTD unit	12
Sensor type	Pl 100 as per EN 60751; connection of Ni 100 and Ni 320 sensors possible. The measured values must be converted in the evaluation unit.

Temperature Measured Values

Unit of measurement for temperature	°C or °F, can be adjusted
Pl 100	199 °C to 800 °C (376 °F to 1472 °F)
Resolution	1 °C or 1 °F
Tolerance	±0.5 % of the measured value ±1 K



12.5 Overcurrent Protection, Phases

12.5.1 Stage with Definite-Time Characteristic Curve

Setting Value for the Function Block Filter

h(0)	-100.000 to 100.000	Increments of 0.001
h(1)	-100.000 to 100.000	Increments of 0.001
h(2)	-100.000 to 100.000	Increments of 0.001
h(3)	-100.000 to 100.000	Increments of 0.001
h(4)	-100.000 to 100.000	Increments of 0.001

Setting Values for Protection Stage

Method of measurement		Fundamental component RMS value	..
Threshold value ²⁴	1 A @ 50 and 100 Irated	0.030 A to 35.000 A	Increments of 0.001 A
	5 A @ 50 and 100 Irated	0.15 A to 175.00 A	Increments of 0.01 A
	1 A @ 1.6 Irated	0.001 A to 1.600 A	Increments of 0.001 A
	5 A @ 1.6 Irated	0.005 A to 8.000 A	Increments of 0.001 A
Dropout ratio		0.90 to 0.99	Increments of 0.01
Time delay		0.00 s to 60.00 s	Increments of 0.01 s
Dropout delay		0.00 s to 60.00 s	Increments of 0.01 s
Pickup delay		0.00 s to 60.00 s	Increments of 0.01 s

Dropout

The greater dropout differential ($= | \text{pickup value} - \text{dropout value} |$) of the following 2 criteria applies:

Dropout differential derived from the parameter Dropout ratio	
If this parameter is not available, a dropout ratio of 95 % applies for overcurrent and of 105 % for undercurrent functionality.	
Minimum absolute dropout differential	
Protection-class current transformer	35 mA sec. ($I_{\text{rated}} = 1 \text{ A}$) or 75 mA sec. ($I_{\text{rated}} = 5 \text{ A}$)
Instrument current transformer	0.5 mA sec. ($I_{\text{rated}} = 1 \text{ A}$) or 2.5 mA sec. ($I_{\text{rated}} = 5 \text{ A}$)

Times

Operate time with time delay = 0 ms	Approx. 25 ms + OOT ²⁵ at 50 Hz Approx. 22 ms + OOT at 60 Hz
Extension of the operate time during operation with transformer inrush-current detection	Approx. 10 ms
Dropout time	Approx. 20 ms + OOT

²⁴ If you have selected the method of measurement = RMS value, do not set the threshold value under 0.1 I_{rated} .

²⁵ OOT (Output Operating Time) additional delay of the output medium used, for example 5 ms with fast relays

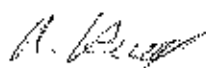

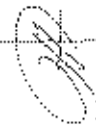

Frequency Operating Range

$0.9 \leq (f/f_{rated} \leq 1.1)$	According to specified tolerances
$10 \text{ Hz} \leq f < 0.9 f_{rated}$ $1.1 f_{rated} < f \leq 80 \text{ Hz}$	Slightly expanded tolerances
$f < 10 \text{ Hz}$ $f > 80 \text{ Hz}$	Active

Tolerances

Currents, method of measurement = fundamental component	\pm % of the setting value or 5 mA ($I_{rated} = 1 \text{ A}$) or 25 mA ($I_{rated} = 5 \text{ A}$), ($f_{rated} \pm 10 \%$)
Currents, method of measurement = RMS value, no filter applied (33 % harmonics, in relation to fundamental component)	
Up to 30th harmonic	1 % of the setting value or 5 mA ($I_{rated} = 1 \text{ A}$) or 25 mA ($I_{rated} = 5 \text{ A}$), ($f_{rated} \pm 10 \%$)
Up to 50th harmonic, $f_{max} = 50 \text{ Hz}$	3 % of the setting value or 20 mA ($I_{rated} = 1 \text{ A}$) or 100 mA ($I_{rated} = 5 \text{ A}$), ($f_{rated} \pm 10 \%$)
Up to 50th harmonic, $f_{max} = 60 \text{ Hz}$	4 % of the setting value or 20 mA ($I_{rated} = 1 \text{ A}$) or 100 mA ($I_{rated} = 5 \text{ A}$), ($f_{rated} \pm 10 \%$)
Currents, method of measurement = RMS value with filter for the compensation of the amplitude attenuation due to the anti-aliasing filter (33 % harmonics, in relation to the fundamental component)	
Up to 30 harmonic	1 % of the setting value or 5 mA ($I_{rated} = 1 \text{ A}$) or 25 mA ($I_{rated} = 5 \text{ A}$), ($f_{rated} \pm 10 \%$)
Up to 50th harmonic, $f_{max} = 50 \text{ Hz}$	2 % of the setting value or 10 mA ($I_{rated} = 1 \text{ A}$) or 50 mA ($I_{rated} = 5 \text{ A}$), ($f_{rated} \pm 10 \%$)
Up to 50th harmonic, $f_{max} = 60 \text{ Hz}$	3 % of the setting value or 20 mA ($I_{rated} = 1 \text{ A}$) or 100 mA ($I_{rated} = 5 \text{ A}$), ($f_{rated} \pm 10 \%$)
Currents, method of measurement = RMS value with filter for the gain of harmonics (including compensation of the amplitude attenuation) ³⁶ (33 % harmonics, in relation to the fundamental component)	
Up to 30 harmonic	1.5 % of the setting value or 10 mA ($I_{rated} = 1 \text{ A}$) or 50 mA ($I_{rated} = 5 \text{ A}$), ($f_{rated} \pm 10 \%$) ³⁷
Up to 50th harmonic, $f_{max} = 50 \text{ Hz}$	3 % of the setting value or 20 mA ($I_{rated} = 1 \text{ A}$) or 100 mA ($I_{rated} = 5 \text{ A}$), ($f_{rated} \pm 10 \%$) ³⁸
Up to 50th harmonic, $f_{max} = 60 \text{ Hz}$	4 % of the setting value or 20 mA ($I_{rated} = 1 \text{ A}$) or 100 mA ($I_{rated} = 5 \text{ A}$), ($f_{rated} \pm 10 \%$) ³⁹
Time delays	1 % of the setting value or 10 ms

³⁶ In case that the filter response exactly matches the user-defined gain factors

³⁷ In case that the user-defined gain factor is set below 3. The tolerance increases, if the gain factor is larger.

³⁸ In case that the user-defined gain factor is set below 7. The tolerance increases, if the gain factor is larger.

³⁹ In case that the user-defined gain factor is set below 7. The tolerance increases, if the gain factor is larger.

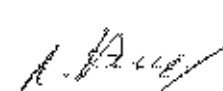
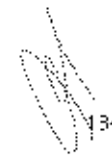

Influencing Variables for Thresholds

Transient excess pickup in method of measurement = fundamental component, for $t > 100$ ms (with complete unbalance)	< 5 %
--	-------

12.5.2 Stage with Inverse-Time Characteristic Curve

Setting Value for the Function Block Filter

h(0)	-100.000 to 100.000	Increments of 0.001
h(1)	100.000 to 100.000	Increments of 0.001
h(2)	-100.000 to 100.000	Increments of 0.001
h(3)	-100.000 to 100.000	Increments of 0.001
h(4)	-100.000 to 100.000	Increments of 0.001

Setting Values for Protection Stage

Method of measurement		Fundamental component RMS value	
Threshold value	1 A @ 50 and 100 Irated	0.030 A to 35.000 A	increments of 0.001 A
	5 A @ 50 and 100 Irated	0.15 A to 175.00 A	Increments of 0.01 A
	1 A @ 1.6 Irated	0.001 A to 1.600 A	increments of 0.001 A
	5 A @ 1.6 Irated	0.005 A to 8.000 A	increments of 0.001 A
Dropout		Disk emulation Instantaneous	
Time multiplier		0.00 to 15.00	increments of 0.01
Pickup delay		0.00 s to 60.00 s	increments of 0.01 s
Minimum time of the curve		0.00 s to 1.00 s	increments of 0.01 s
Additional time delay		0.00 s to 60.00 s	increments of 0.01 s

Dropout

The greater dropout differential (= | pickup value - dropout value |) of the following 2 criteria applies:

Dropout	95 % of 1.1 · threshold value
Minimum absolute dropout differential	
Protection-class current transformer	±5 mA sec. ($I_{rated} = 1$ A) or 75 mA sec. ($I_{rated} = 5$ A)
Instrument current transformer	0.5 mA sec. ($I_{rated} = 1$ A) or 2.5 mA sec. ($I_{rated} = 5$ A)

Reset of the Integration Timer

Instantaneous	With dropout
Disk emulation	Approx. < 0.90 · threshold value

Operate Curves and Dropout-Time Characteristic Curves according to IEC

Extension of the operate time during operation with transformer inrush-current detection	Approx. 10 ms
--	---------------

M. Kopp

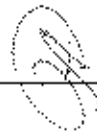

NORMAL INVERSE: Type A

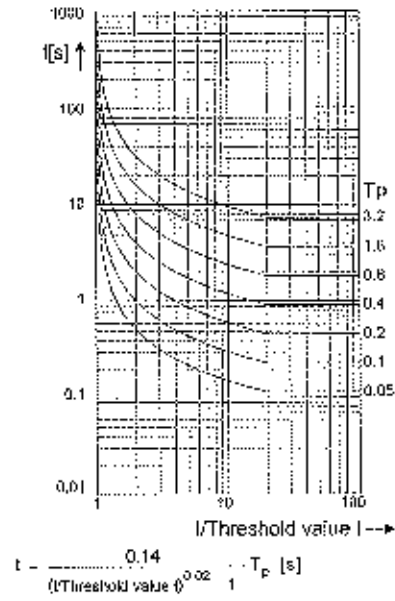

RESET NORMAL INVERSE: Type A

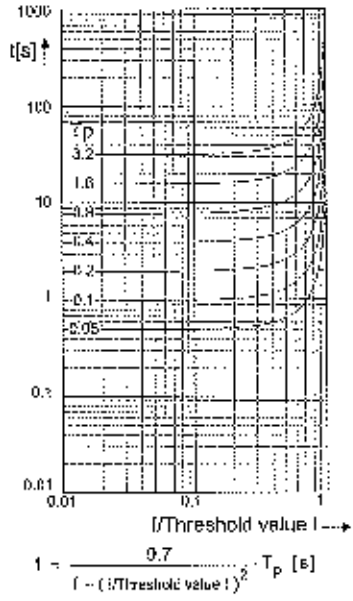

VERY INVERSE: Type B

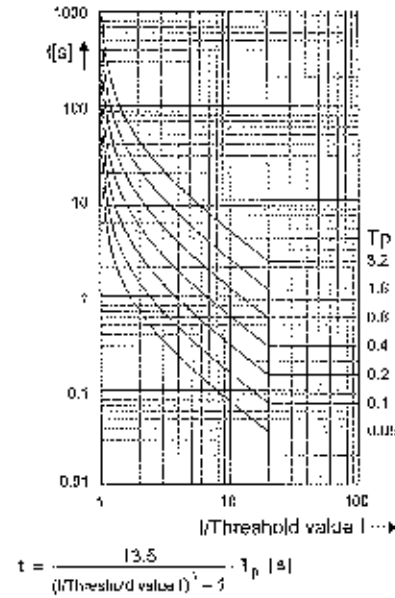

RESET VERY INVERSE: Type B

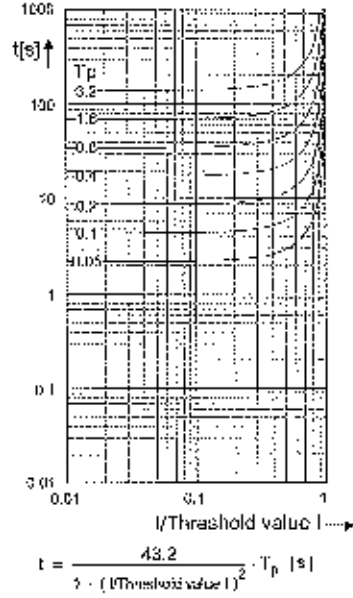

(see also IEC 60898-1, 60947)

Figure 12-1 Operate Curves and Dropout Time Characteristic Curves According to IEC

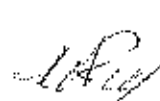

EXTREMELY INVERSE: Type C

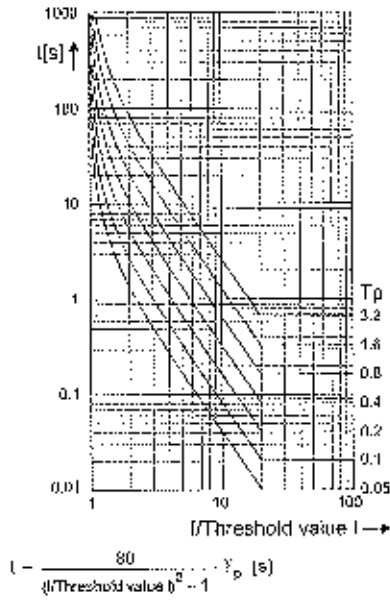

RESET EXTREMELY INVERSE: Type C

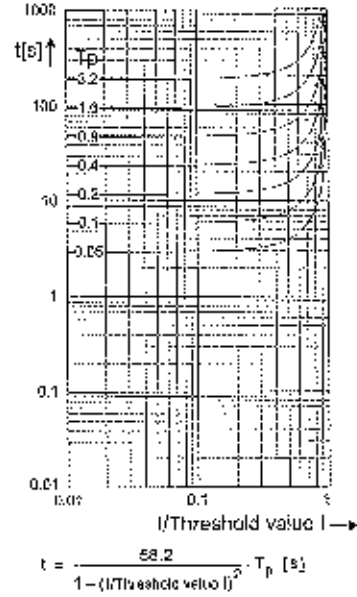

LONG-TIME INVERSE: Type B

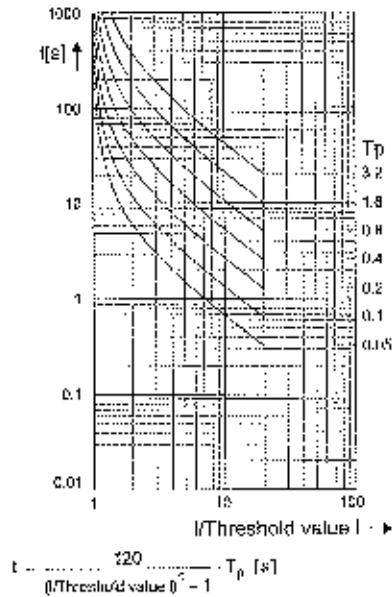

RESET LONG-TIME INVERSE: Type B

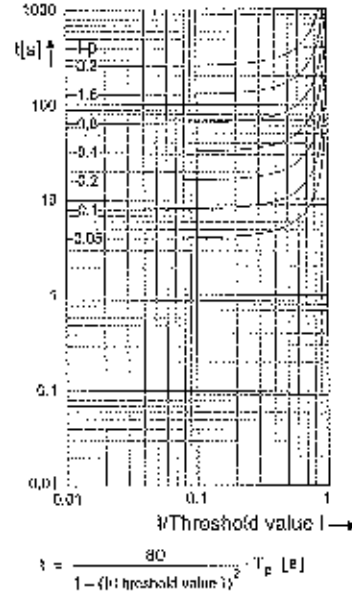

[03Sep12:300213 CI.M 1.00.00]

Figure 12-2 Operate Curves and Dropout-Time Characteristic Curves According to IFC

Operate Curves and Dropout-Time Characteristic Curves According to ANSI/IEEE

Inverse: Type C

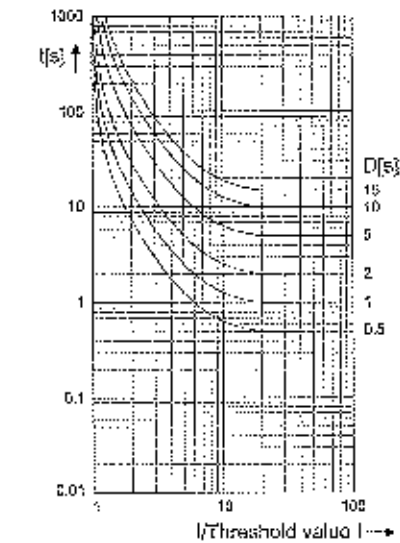

$$t = \left(\frac{44.6705}{(I/Threshold\ value\ I)^{2.22220}} + 0.8983 \right) \cdot D \quad [s]$$

RESET INVERSE: Type C

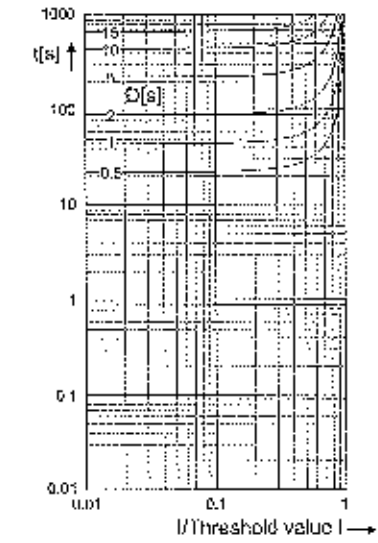

$$t = \frac{44}{1 - (I/Threshold\ value\ I)^{2.00000}} \cdot D \quad [s]$$

SHORT INVERSE

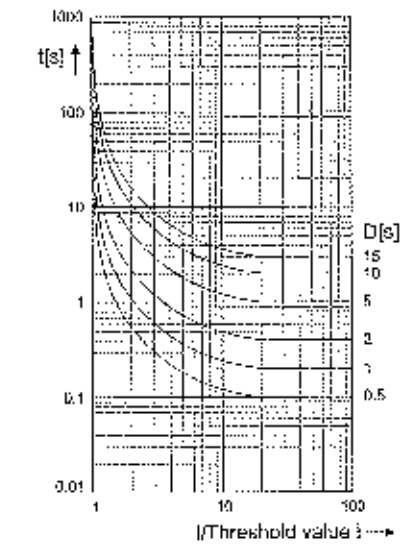

$$t = \left(\frac{3.3916}{(I/Threshold\ value\ I)^{1.25000}} + 0.16935 \right) \cdot D \quad [s]$$

RESET SHORT INVERSE

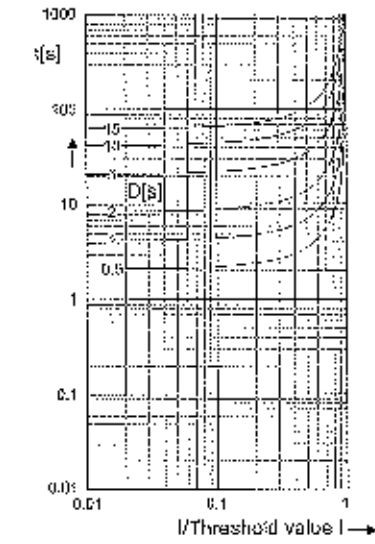

$$t = \frac{4.155}{1 - (I/Threshold\ value\ I)^{1.25000}} \cdot D \quad [s]$$

Idex:0410: 020213-01.01.7. en_051

Figure 12-3 Operate Curves and Dropout-Time Characteristic Curves According to ANSI/IEEE

LONG INVERSE

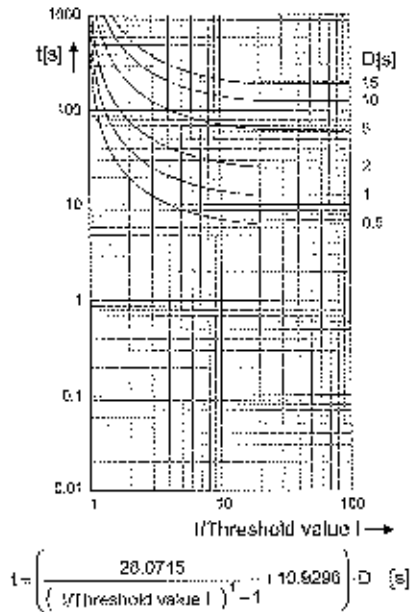

RESET LONG INVERSE

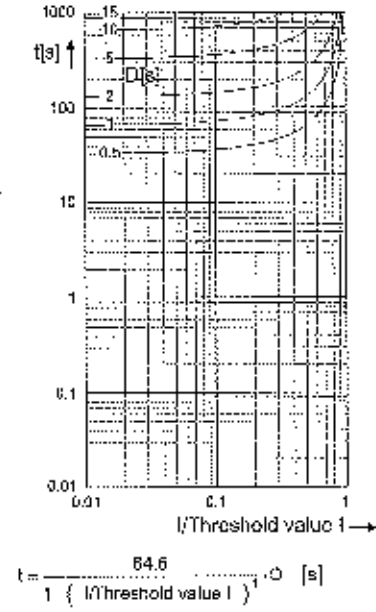

MODERATELY INVERSE

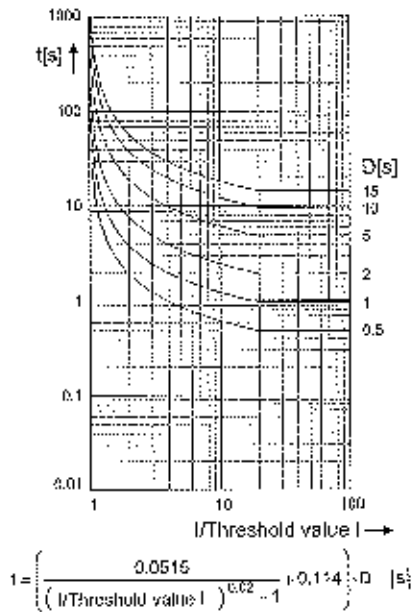

RESET MODERATELY INVERSE

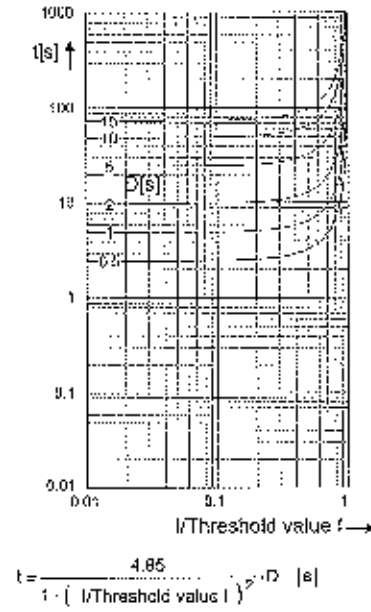

[www.siprotec.com/pdf/2_en/04]

Figure 12-4 Operate Curves and Dropout-Time Characteristic Curves According to ANSI/IEEE

A. P. ...

B

VERY INVERSE

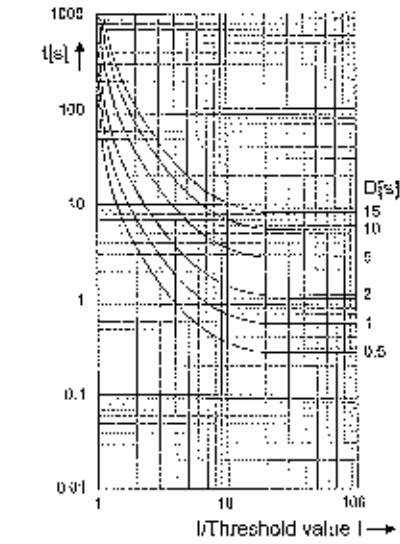

$$t = \left(\frac{19.61}{\left(\frac{I}{\text{Threshold value } I} \right)^2 - 1} + 0.491 \right) \cdot D \quad [s]$$

RESET VERY INVERSE

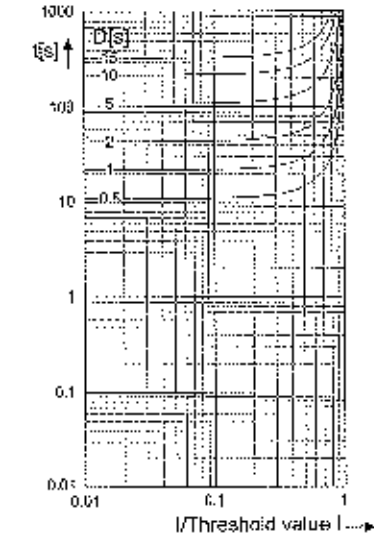

$$t = \frac{21.6}{1 - \left(\frac{I}{\text{Threshold value } I} \right)^2} \cdot D \quad [s]$$

EXTREMELY INVERSE

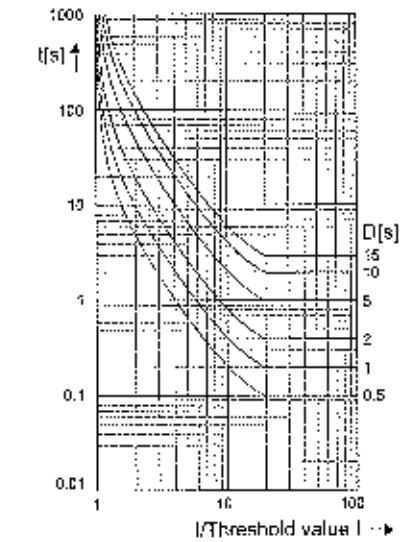

$$t = \left(\frac{26.2}{\left(\frac{I}{\text{Threshold value } I} \right)^2 - 1} + 0.1217 \right) \cdot D \quad [s]$$

RESET EXTREMELY INVERSE

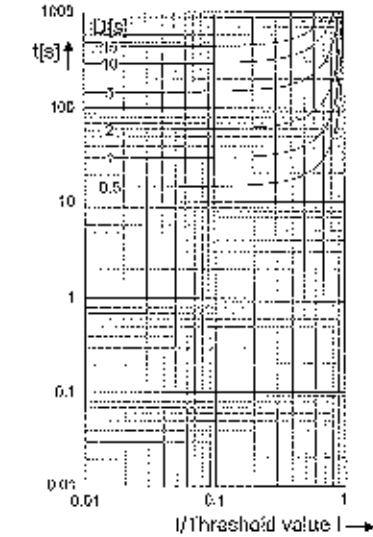

$$t = \frac{29.1}{1 - \left(\frac{I}{\text{Threshold value } I} \right)^2} \cdot D \quad [s]$$

Downloaded 09/21/2016 12:01:01 (2. en, W)

Figure 12-5 Tripping Characteristic Curves and Dropout Characteristic Curves According to ANSI/IEEE

DEFINITE INVERSE

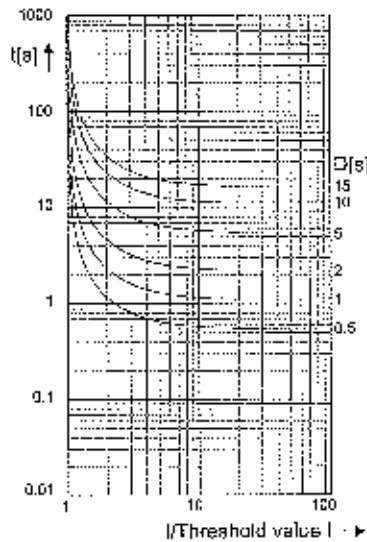

$$t = \left(\frac{2.3985}{\left(\frac{I}{\text{Threshold value } I} \right)^{1.5625} - 1} + 1.09795 \right) \cdot D \quad [s]$$

RESET DEFINITE INVERSE

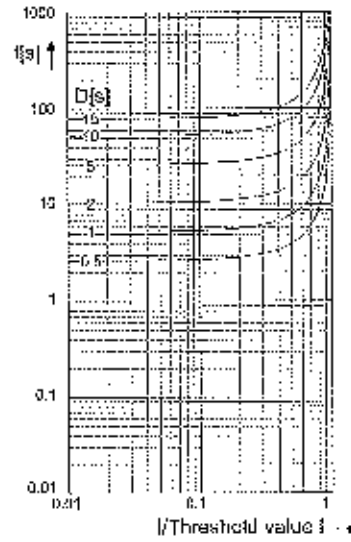

$$t = \frac{5.197}{1 - \left(\frac{I}{\text{Threshold value } I} \right)^{1.5625}} \cdot D \quad [s]$$

Note: IGrd threshold stands for ground fault instead of the I threshold.

(document 080213 01.01.2_en_US)

Figure 12-6 Operate Curves and Dropout-Time Characteristic Curves According to ANSI/IEEE

Frequency Operating Range

$0.9 \leq f/f_{rated} \leq 1.1$	According to specified tolerances
$10 \text{ Hz} < f < 0.9 f_{rated}$	Slightly expanded tolerances
$1.1 f_{rated} < f \leq 80 \text{ Hz}$	
$f < 10 \text{ Hz}$	Active
$f > 80 \text{ Hz}$	

Tolerances

Currents, method of measurement = fundamental component	1 % of the setting value or 5 mA ($I_{rated} = 1 \text{ A}$) or 25 mA ($I_{rated} = 5 \text{ A}$), ($f_{rated} \pm 10 \%$)
Currents, method of measurement = RMS value, no filter applied (33 % harmonics, in relation to fundamental component)	
Up to 30th harmonic	1 % of the setting value or 5 mA ($I_{rated} = 1 \text{ A}$) or 25 mA ($I_{rated} = 5 \text{ A}$), ($f_{rated} \pm 10 \%$)
Up to 50th harmonic, $f_{rated} = 50 \text{ Hz}$	3 % of the setting value or 20 mA ($I_{rated} = 1 \text{ A}$) or 100 mA ($I_{rated} = 5 \text{ A}$), ($f_{rated} \pm 10 \%$)
Up to 50th harmonic, $f_{rated} = 60 \text{ Hz}$	4 % of the setting value or 20 mA ($I_{rated} = 1 \text{ A}$) or 100 mA ($I_{rated} = 5 \text{ A}$), ($f_{rated} \pm 10 \%$)
Currents, method of measurement = RMS value with filter for the compensation of the amplitude attenuation due to the anti-aliasing filter (33 % harmonics, in relation to the fundamental component)	
Up to 30 harmonic	1 % of the setting value or 5 mA ($I_{rated} = 1 \text{ A}$) or 25 mA ($I_{rated} = 5 \text{ A}$), ($f_{rated} \pm 10 \%$)

P. Dery

[Handwritten signature]

Up to 50th harmonic, $f_{rated} = 50$ Hz	2 % of the setting value or 10 mA ($I_{rated} = 1$ A) or 50 mA ($I_{rated} = 5$ A), ($f_{rated} + 10$ %)
Up to 50th harmonic, $f_{rated} = 60$ Hz	3 % of the setting value or 20 mA ($I_{rated} = 1$ A) or 100 mA ($I_{rated} = 5$ A), ($f_{rated} + 10$ %)
Currents, method of measurement = RMS value with filter for the gain of harmonics (including compensation of the amplitude attenuation ⁴⁰) (33 % harmonics, in relation to the fundamental component)	
Up to 30 harmonic	1.5 % of the setting value or 10 mA ($I_{rated} = 1$ A) or 50 mA ($I_{rated} = 5$ A), ($f_{rated} \pm 10$ %) ⁴¹
Up to 50th harmonic, $f_{rated} = 50$ Hz	3% of the setting value or 20 mA ($I_{rated} = 1$ A) or 100 mA ($I_{rated} = 5$ A), ($f_{rated} \pm 10$ %) ⁴²
Up to 50th harmonic, $f_{rated} = 60$ Hz	4 % of the setting value or 20 mA ($I_{rated} = 1$ A) or 100 mA ($I_{rated} = 5$ A), ($f_{rated} + 10$ %) ⁴³
Operate time for $2 \leq I/I$ threshold value ≤ 20	5 % of the reference (calculated) value +2 % current tolerance or 30 ms
Dropout time for I/I threshold value ≤ 0.90	5 % of the reference (calculated) value +2 % current tolerance or 30 ms
Time delays	1 % of the setting value or 10 ms

Influencing Variables for Thresholds

Transient excess pickup in method of measurement – fundamental component, for $\tau > 100$ ms (with complete unbalance)	< 5 %
---	-------

12.5.3 Stage with User-Defined Characteristic Curve

Setting Value for the Function Block Filter

h(0)	-100.000 to 100.000	Increments of 0.001
h(1)	-100.000 to 100.000	Increments of 0.001
h(2)	-100.000 to 100.000	Increments of 0.001
h(3)	-100.000 to 100.000	Increments of 0.001
h(4)	-100.000 to 100.000	Increments of 0.001

Setting Values for Protection Stage

Method of measurement		Fundamental component RMS value	--
Threshold value	1 A @ 50 and 100 Irated	0.030 A to 35.000 A	Increments of 0.001 A
	5 A @ 50 and 100 Irated	0.15 A to 175.00 A	Increments of 0.01 A
	1 A @ 1.6 Irated	0.001 A to 1.600 A	Increments of 0.001 A
	5 A @ 1.6 Irated	0.005 A to 8.000 A	Increments of 0.001 A
Dropout		Disk emulation Instantaneous	--

⁴⁰ in case that the filter response exactly matches the user-defined gain factors

⁴¹ in case that the user-defined gain factor is set below 3. The tolerance increases, if the gain factor is larger.

⁴² in case that the user-defined gain factor is set below 7. The tolerance increases, if the gain factor is larger.

⁴³ in case that the user-defined gain factor is set below 7. The tolerance increases, if the gain factor is larger.

Technical Data

12.5 Overcurrent Protection, Phases

Time multiplier	0.05 to 15.00	Increments of 0.01
Number of value pairs for the operate curve	2 to 30	Increments of 1
X values of the operate curve	1.00 p.u. to 66.67 p.u.	Increments of 0.01 p.u.
Y values of the operate curve	0.00 s to 999.00 s	Increments of 0.01 s
Number of value pairs for the dropout characteristic curve	2 to 30	Increments of 1
X values of the dropout characteristic curve	0.05 p.u. to 0.95 p.u.	Increments of 0.01 p.u.
Y values of the dropout characteristic curve	0.00 s to 999.00 s	Increments of 0.01 s

Dropout

The greater dropout differential (= | pickup value - dropout value |) of the following 2 criteria applies:

Dropout	95 % of $1.1 \cdot$ threshold value
Minimum absolute dropout differential	
Protection-class current transformer	15 mA sec. ($I_{rated} = 1$ A) or 75 mA sec. ($I_{rated} = 5$ A)
Instrument current transformer	0.5 mA sec. ($I_{rated} = 1$ A) or 2.5 mA sec. ($I_{rated} = 5$ A)

Reset of the Integration Timer

Instantaneous	With dropout
Disk emulation	Approx. $< 0.90 \cdot$ threshold value

Frequency Operating Range

$0.9 < f/f_{rated} \leq 1.1$	According to specified tolerances
$10 \text{ Hz} \leq f < 0.9 f_{rated}$	Slightly expanded tolerances
$1.1 f_{rated} < f \leq 80 \text{ Hz}$	
$f < 10 \text{ Hz}$	Active
$f > 80 \text{ Hz}$	

Tolerances

Currents, method of measurement = fundamental component	1 % of the setting value or 5 mA ($I_{rated} = 1$ A) or 25 mA ($I_{rated} = 5$ A), ($f_{rated} \pm 10$ %)
Currents, method of measurement = RMS value, no filter applied (33 % harmonics, in relation to fundamental component)	
Up to 30th harmonic	1 % of the setting value or 5 mA ($I_{rated} = 1$ A) or 25 mA ($I_{rated} = 5$ A), ($f_{rated} \pm 10$ %)
Up to 50th harmonic, $f_{rated} = 50$ Hz	3 % of the setting value or 20 mA ($I_{rated} = 1$ A) or 100 mA ($I_{rated} = 5$ A), ($f_{rated} \pm 10$ %)
Up to 50th harmonic, $f_{rated} = 60$ Hz	4 % of the setting value or 20 mA ($I_{rated} = 1$ A) or 100 mA ($I_{rated} = 5$ A), ($f_{rated} \pm 10$ %)

Currents, method of measurement = RMS value with filter for the compensation of the amplitude attenuation due to the anti-aliasing filter (33 % harmonics, in relation to the fundamental component)	
Up to 30 harmonic	1 % of the setting value or 5 mA ($I_{rated} = 1 \text{ A}$) or 25 mA ($I_{rated} = 5 \text{ A}$), ($f_{rated} \pm 10 \%$)
Up to 50th harmonic, $f_{rated} = 50 \text{ Hz}$	2 % of the setting value or 10 mA ($I_{rated} = 1 \text{ A}$) or 50 mA ($I_{rated} = 5 \text{ A}$), ($f_{rated} + 10 \%$)
Up to 50th harmonic, $f_{rated} = 60 \text{ Hz}$	3 % of the setting value or 20 mA ($I_{rated} = 1 \text{ A}$) or 100 mA ($I_{rated} = 5 \text{ A}$), ($f_{rated} + 10 \%$)
Currents, method of measurement = RMS value with filter for the gain of harmonics (including compensation of the amplitude attenuation ⁴⁴) (33 % harmonics, in relation to the fundamental component)	
Up to 30 harmonic	1.5 % of the setting value or 10 mA ($I_{rated} = 1 \text{ A}$) or 50 mA ($I_{rated} = 5 \text{ A}$), ($f_{rated} \pm 10 \%$) ⁴⁵
Up to 50th harmonic, $f_{rated} = 50 \text{ Hz}$	3 % of the setting value or 20 mA ($I_{rated} = 1 \text{ A}$) or 100 mA ($I_{rated} = 5 \text{ A}$), ($f_{rated} \pm 10 \%$) ⁴⁶
Up to 50th harmonic, $f_{rated} = 60 \text{ Hz}$	4 % of the setting value or 20 mA ($I_{rated} = 1 \text{ A}$) or 100 mA ($I_{rated} = 5 \text{ A}$), ($f_{rated} \pm 10 \%$) ⁴⁷
Operate time for $2 \leq I/I$ threshold value ≤ 20	5 % of the reference (calculated) value +2 % current tolerance or 30 ms
Dropout time for I/I threshold value ≤ 0.90	5 % of the reference (calculated) value +2 % current tolerance or 30 ms
Time delays	1 % of the setting value or 10 ms

Influencing Variables for Thresholds

Transient excess pickup in method of measurement = fundamental component, for $\tau > 100 \text{ ms}$ (with complete unbalance)	< 5 %
---	-------

Operate Curves and Dropout-Time Characteristic Curves according to IEC

Extension of the operate time during operation with transformer inrush-current detection	Approx. 10 ms
---	---------------

⁴⁴ In case that the filter response exactly matches the user-defined gain factors

⁴⁵ In case that the user-defined gain factor is set below 3. The tolerance increases, if the gain factor is larger.

⁴⁶ In case that the user-defined gain factor is set below 7. The tolerance increases, if the gain factor is larger.

⁴⁷ In case that the user-defined gain factor is set below 7. The tolerance increases, if the gain factor is larger.

M. Key

M



12.6 Voltage-Dependent Overcurrent Protection, Phases

Setting Values for All Stage Types

Method of measurement	Fundamental component RMS value	-
Overcurrent threshold value	For $I_{rated} = 1 \text{ A}$	0.030 A to 35.000 A Increments of 0.001 A
	For $I_{rated} = 5 \text{ A}$	0.15 A to 175.00 A Increments of 0.01 A
Time delay	0.10 s to 60.00 s	Increments of 0.01 s

Setting Values for Inverse Time-Overcurrent Stages

Method of measurement	Fundamental component RMS value	-
Dropout ratio of undervoltage ⁴⁸	1.01 to 1.20	Increments of 0.01
Undervoltage threshold value ⁴⁹	0.300 V to 175.000 V	Increments of 0.001 V
Dropout	Disk emulation Instantaneous	-
Time multiplier	0.05 to 15.00	Increments of 0.01

Setting Values for Definite Time-Overcurrent Stages

Seal-in voltage	0.300 V to 175.000 V	Increments of 0.001 V
Phase-to-phase voltage	0.300 V to 175.000 V	Increments of 0.001 V
Negative-sequence voltage V2	0.300 V to 200.000 V	Increments of 0.001 V
Time delay	0.00 s to 60.00 s	Increments of 0.01 s
Duration of V-seal-in time	0.10 s to 60.00 s	Increments of 0.01 s

Dropout for Inverse Time-Overcurrent Stages

The greater dropout differential (= | pickup value - dropout value |) of the following 2 criteria applies:

Dropout	
Current	95 % of $1.1 \cdot \text{threshold value}$
Voltage ⁴⁸	105 % of threshold value
Minimum absolute dropout differential	
Protection-class current transformer	15 mA sec. ($I_{rated} = 1 \text{ A}$) or 75 mA sec. ($I_{rated} = 5 \text{ A}$)
Instrument current transformer	0.5 mA sec. ($I_{rated} = 1 \text{ A}$) or 2.5 mA sec. ($I_{rated} = 5 \text{ A}$)
Voltage transformer ⁴⁸	150 mV sec.

Reset of the Integration Timer for Inverse Time-Overcurrent Stages

Instantaneous	With dropout
Disk emulation	Approx. $< 0.90 \cdot \text{threshold value}$



⁴⁸The value is for the inverse time-overcurrent voltage-released stage.

Handwritten mark at the bottom left of the page.



Dropout for Definite Time-Overcurrent Stages

Dropout differential derived from the parameter Dropout ratio If this parameter is not available, a dropout ratio of 95 % applies for overcurrent/overvoltage and of 105 % for undervoltage functionality.	
Minimum absolute dropout differential	
Protection-class current transformer	15 mA sec. ($I_{rated} = 1 A$) or 75 mA sec. ($I_{rated} = 5 A$)
Instrument current transformer	0.5 mA sec. ($I_{rated} = 1 A$) or 2.5 mA sec. ($I_{rated} = 5 A$)
Voltage transformer	150 mV sec.

Operate Curves and Dropout-Time Characteristic Curves According to IEC

Extension of the operate time during operation with inrush current detection	Approx. 30 ms
--	---------------

The operate curves and dropout-time characteristic curves according to IEC can be found in the chapter Technical Data under Inverse-Time Overcurrent Protection.

Operate Curves and Dropout-Time Characteristic Curves According to ANSI/IEEE

The operate curves and dropout-time characteristic curves according to IEC can be found in the chapter Technical Data under Inverse Time Overcurrent Protection.

Frequency Operating Range

$0.9 < f/f_{rated} \leq 1.1$	According to specified tolerances
$10 \text{ Hz} \leq f < 0.9 f_{rated}$	Slightly expanded tolerances
$1.1 f_{rated} < f \leq 80 \text{ Hz}$	
$f < 10 \text{ Hz}$ $f > 80 \text{ Hz}$	Inactive

Tolerances

Currents, method of measurement = fundamental component	1 % of the setting value or 5 mA ($I_{rated} = 1 A$) or 25 mA ($I_{rated} = 5 A$), ($f_{rated} \pm 10 \%$)
Currents, method of measurement = RMS value (33 % part of harmonic in relation to fundamental component)	
Up to 30th harmonic	1 % of the setting value or 5 mA ($I_{rated} = 1 A$) or 25 mA ($I_{rated} = 5 A$), ($f_{rated} \pm 10 \%$)
Up to 50th harmonic, $f_{rated} = 50 \text{ Hz}$	3 % of the setting value or 20 mA ($I_{rated} = 1 A$) or 100 mA ($I_{rated} = 5 A$), ($f_{rated} \pm 10 \%$)
Up to 50th harmonic, $f_{rated} = 60 \text{ Hz}$	4 % of the setting value or 20 mA ($I_{rated} = 1 A$) or 100 mA ($I_{rated} = 5 A$), ($f_{rated} \pm 10 \%$)
Voltage	0.5 % of the setting value or 0.05 V
Operate time for 2 ≤ III threshold value ≤ 20	5 % of the reference (calculated) value – 2 % current tolerance or 30 ms
Dropout time for III threshold value ≤ 0.90	5 % of the reference (calculated) value + 2 % current tolerance or 30 ms

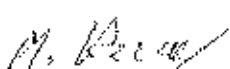

Influencing Variables for Thresholds

Transient excess pickup in method of measurement = fundamental component, for $\tau > 100$ ms (with complete unbalance)	< 5 %
---	-------

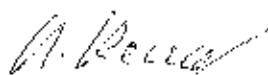

12.7 Overcurrent Protection, Ground

12.7.1 Stage with Definite-Time Characteristic Curve

Setting Values

Method of measurement		Fundamental component RMS value	-
Threshold value ⁴⁹⁾	1 A @ 50 and 100 Irated	0.030 A to 35.000 A	Increments of 0.001 A
	5 A @ 50 and 100 Irated	0.15 A to 175.00 A	Increments of 0.01 A
	1 A @ 1.6 Irated	0.001 A to 1.600 A	Increments of 0.001 A
	5 A @ 1.6 Irated	0.005 A to 8.000 A	Increments of 0.001 A
Dropout ratio		0.90 to 0.99	Increments of 0.01
Time delay		0.00 s to 60.00 s	Increments of 0.01 s
Dropout delay		0.00 s to 60.00 s	Increments of 0.01 s

Dropout

The greater dropout differential (= | pickup value - dropout value |) of the following 2 criteria applies:

Dropout differential derived from the parameter Dropout ratio	
If this parameter is not available, a dropout ratio of 95 % applies for overcurrent and of 105 % for undercurrent functionality.	
Minimum absolute dropout differential	
Protection-class current transformer	15 mA sec. (I _{rated} = 1 A) or 75 mA sec. (I _{rated} = 5 A)
Instrument current transformer	0.5 mA sec. (I _{rated} = 1 A) or 2.5 mA sec. (I _{rated} = 5 A)

Times

Operate time with time delay = 0 ms	Approx. 25 ms + OOT ⁵⁰⁾ at 50 Hz Approx. 22 ms + OOT at 60 Hz
Extension of the operate time during operation with transformer inrush-current detection	Approx. 10 ms
Dropout time	Approx. 20 ms + OOT

Frequency Operating Range

$0.9 \leq f/f_{rated} \leq 1.1$	According to specified tolerances
$10 \text{ Hz} \leq f < 0.9 f_{rated}$	Slightly expanded tolerances
$1.1 f_{rated} < f \leq 80 \text{ Hz}$	
$f < 10 \text{ Hz}$	Active
$f > 80 \text{ Hz}$	

⁴⁹⁾ If you have selected the method of measurement = RMS value, do not set the threshold value under 0.1 I_{rated,sec}.

⁵⁰⁾ OOT (Output Operating Time) additional delay of the output medium used, see Chapter 12.1.4 Relay Outputs.



Tolerances

3I0 measured via I4 ⁵¹ , method of measurement = fundamental component	1 % of the setting value or 5 mA ($I_{rated} = 1 A$) or 25 mA ($I_{rated} = 5 A$), ($f_{rated} \pm 10 \%$)
3I0 measured via I4 ⁵² , method of measurement = RMS value (33 % harmonics, in relation to fundamental component)	
Up to 30th harmonic	1 % of the setting value or 5 mA ($I_{rated} = 1 A$) or 25 mA ($I_{rated} = 5 A$), ($f_{rated} \pm 10 \%$)
Up to 50th harmonic, $f_{rated} = 50 Hz$	3 % of the setting value or 20 mA ($I_{rated} = 1 A$) or 100 mA ($I_{rated} = 5 A$), ($f_{rated} \pm 10 \%$)
Up to 50th harmonic, $f_{rated} = 60 Hz$	4 % of the setting value or 20 mA ($I_{rated} = 1 A$) or 100 mA ($I_{rated} = 5 A$), ($f_{rated} \pm 10 \%$)
Time delays	± % of the setting value or 10 ms

Influencing Variables for Thresholds

Transient excess pickup in method of measurement = fundamental component, for $t > 100 ms$ (with complete unbalance)	< 5 %
--	-------

12.7.2 Stage with Inverse-Time Characteristic Curve

Setting Values

Method of measurement	Fundamental component	–
	RMS value	
Threshold value ⁵³	1 A @ 50 and 100 Irated	0.030 A to 35.000 A Increments of 0.001 A
	5 A @ 50 and 100 Irated	0.15 A to 175.00 A Increments of 0.01 A
	1 A @ 1.6 Irated	0.001 A to 1.600 A Increments of 0.001 A
	5 A @ 1.6 Irated	0.005 A to 8.000 A Increments of 0.001 A
Dropout	Disk emulation	–
	Instantaneous	
Time multiplier	0.00 to 15.00	Increments of 0.01
Minimum time of the curve	0.00 s to 1.00 s	Increments of 0.01 s
Additional time delay	0.00 s to 60.00 s	increments of 0.01 s

Dropout

The greater dropout differential (= | pickup value – dropout value |) of the following 2 criteria applies:

Dropout	95 % of 1.1 · threshold value
Minimum absolute dropout differential	
Protection class current transformer	15 mA sec. ($I_{rated} = 1 A$) or 75 mA sec. ($I_{rated} = 5 A$)
Instrument current transformer	0.5 mA sec. ($I_{rated} = 1 A$) or 2.5 mA sec. ($I_{rated} = 5 A$)

⁵¹ Slightly expanded tolerances will occur during the calculation of 3I0, maximum factor of 2

⁵² Slightly expanded tolerances will occur during the calculation of 3I0, maximum factor of 2

⁵³ If you have selected the method of measurement = RMS value, do not set the threshold value under 0.1 I_{rated}



As Reich

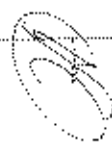

Reset of the Integration Timer

Instantaneous	With dropout
Disk emulation	Approx. < 0.90 · threshold value

Operate Curves and Dropout-Time Characteristic Curves According to IEC

Extension of the operate time during operation with transformer inrush-current detection	Approx. 10 ms
--	---------------

NORMAL INVERSE: Type A

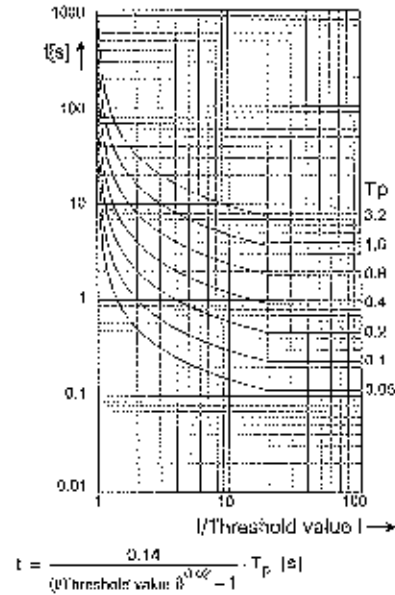

RESET NORMAL INVERSE: Type A

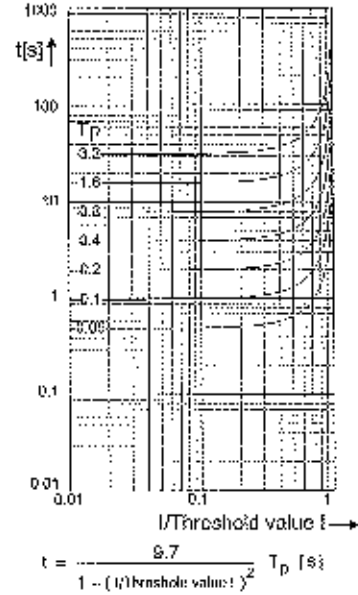

VERY INVERSE: Type B

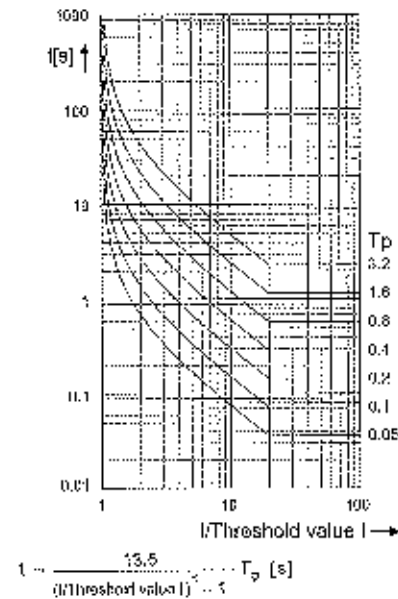

RESET VERY INVERSE: Type B

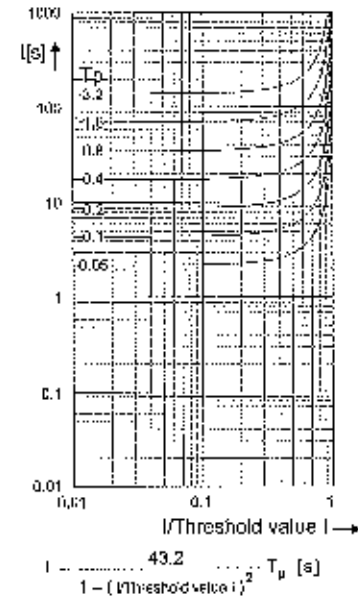

CS2000-65040-017-7, 1. en, 05/16

Figure 12-7 Operate Curves and Dropout-time Characteristic Curves According to IEC

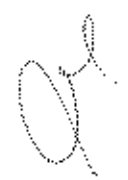

Handwritten mark at the bottom left of the page.



EXTREMELY INVERSE: Type C

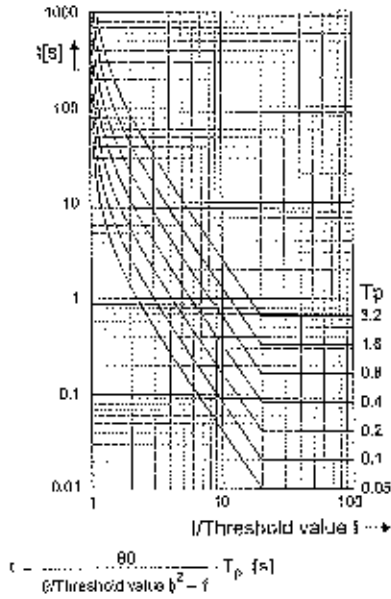

RESET EXTREMELY INVERSE: Type C

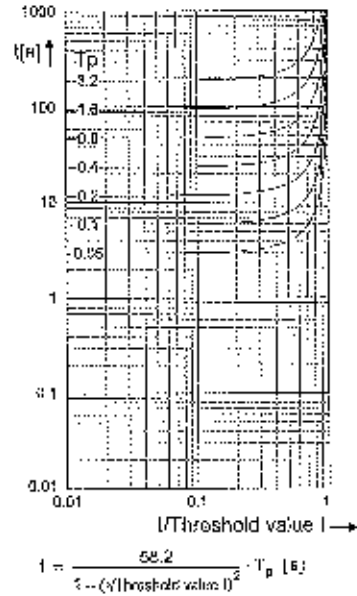

LONG-TIME INVERSE: Type B

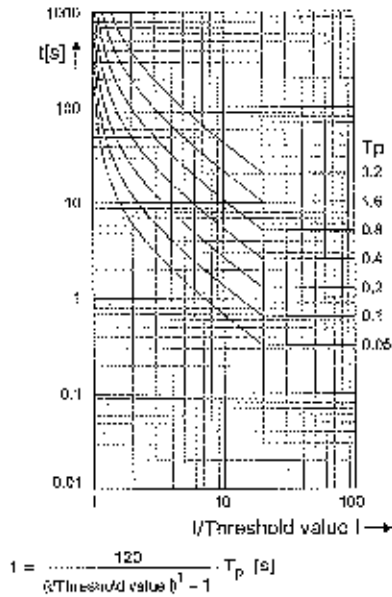

RESET LONG-TIME INVERSE: Type B

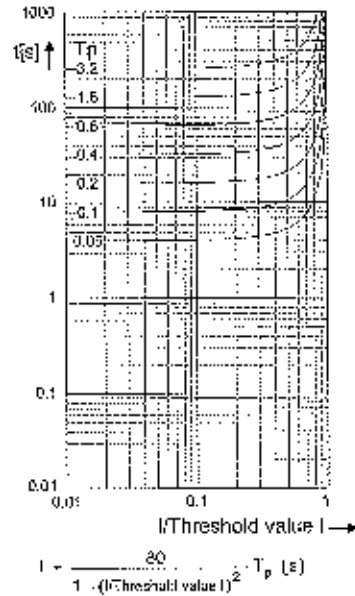

Idavocp2-CB0212-09 Rev. 1.0 (1/2014)

Figure 12.8 Operate Curves and Dropout-Time Characteristic Curves According to IEC



A. P. ...

Operate Curves and Dropout-Time Characteristic Curves According to ANSI/IEEE

Inverse: Type C

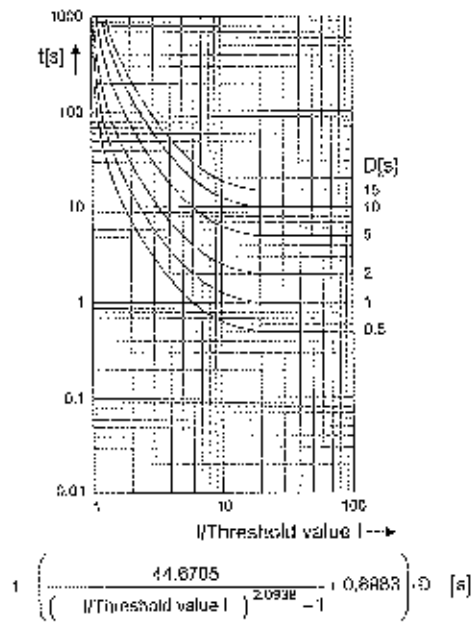

RESET INVERSE: Type C

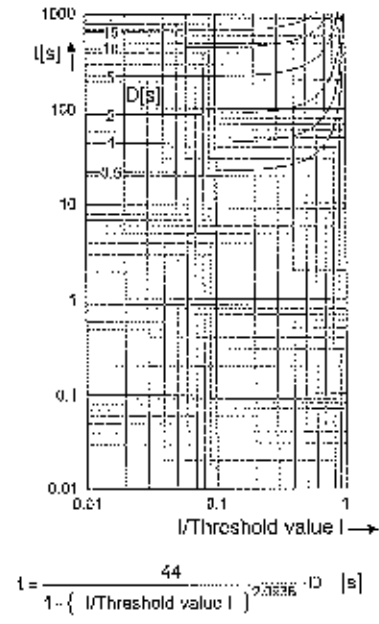

SHORT INVERSE

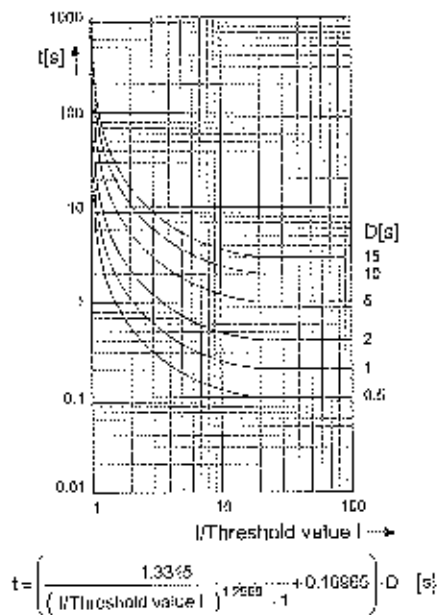

RESET SHORT INVERSE

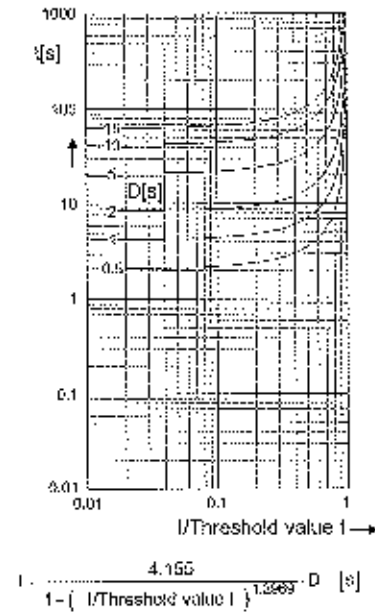

Microlog 680213 D1 cr 2, en, 101

Figure 12-9 Operate Curves and Dropout-Time Characteristic Curves According to ANSI/IEEE



LONG INVERSE

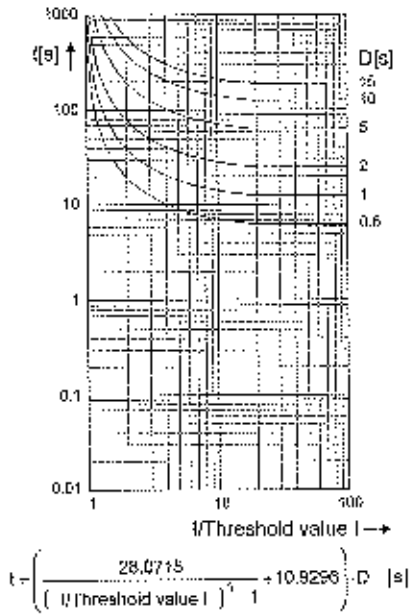

RESET LONG INVERSE

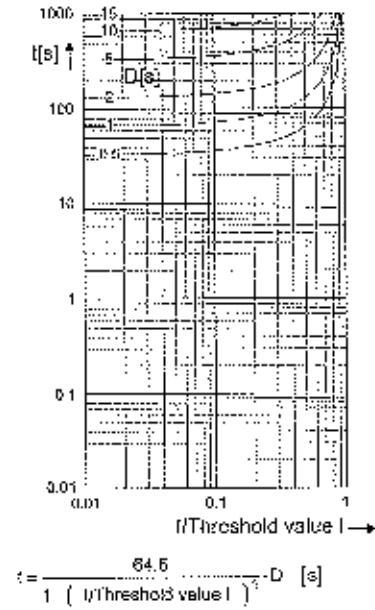

MODERATELY INVERSE

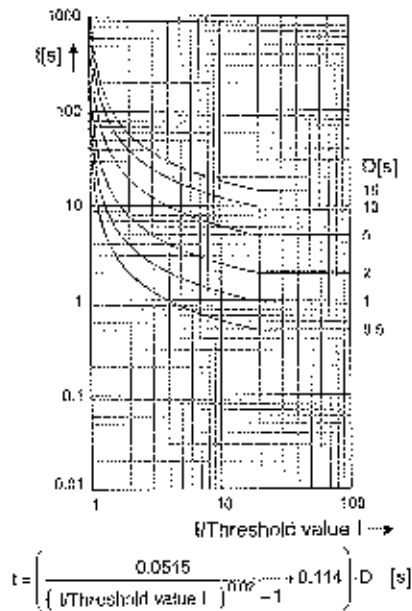

RESET MODERATELY INVERSE

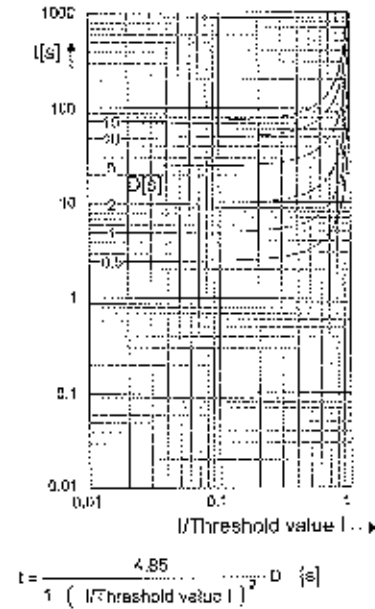

3AWG0012-000017401.00.2.00_314

Figure 12-10 Operate Curves and Dropout-Time Characteristic Curves According to ANSI/IEEE

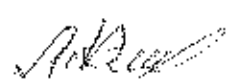



VERY INVERSE

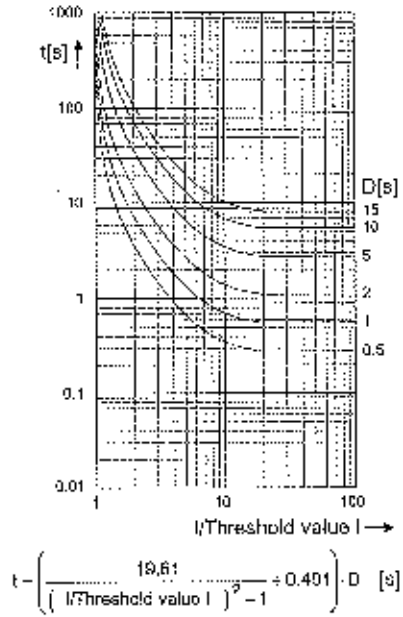

RESET VERY INVERSE

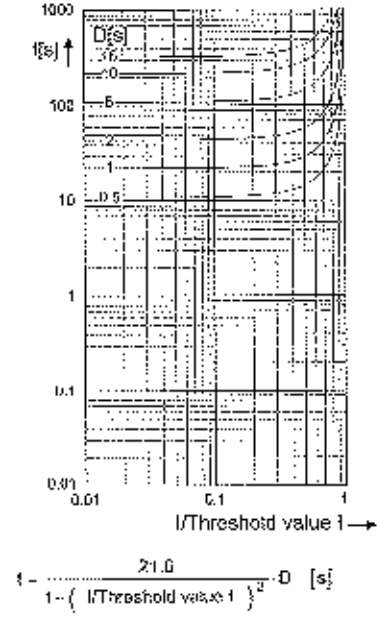

EXTREMELY INVERSE

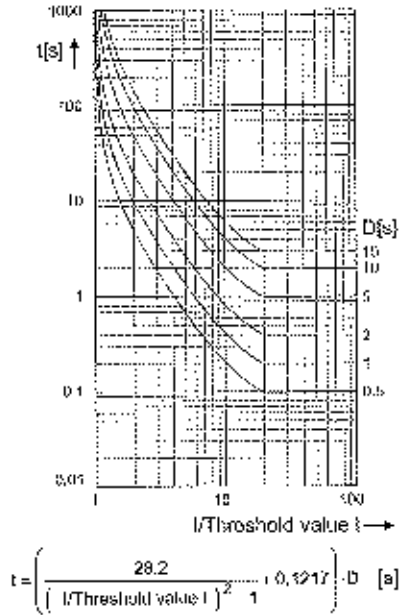

RESET EXTREMELY INVERSE

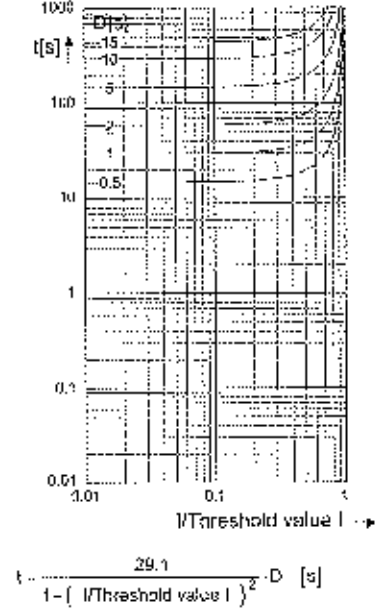

© 2016 Schneider Electric, All Rights Reserved

Figure 12-11 Operate Curves and Dropout-Time Characteristic Curves According to ANSI/IEEE

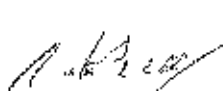

DEFINITE INVERSE

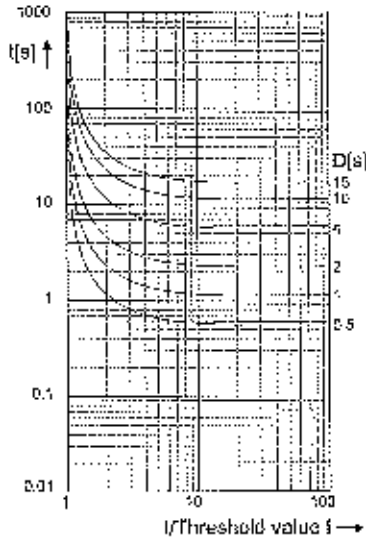

$$t = \left(\frac{2.3985}{\left(\frac{I}{I_{\text{Threshold value I}}} \right)^{1.5625} - 1} + 1.06705 \right) \cdot D \quad [s]$$

RESET DEFINITE INVERSE

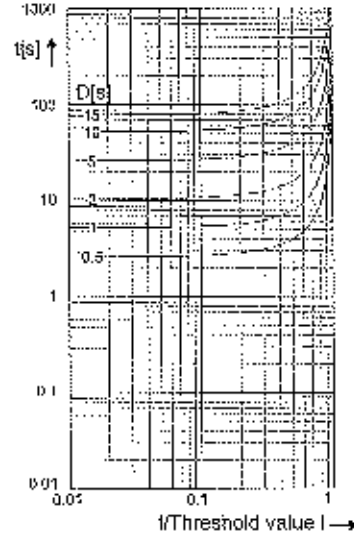

$$t = \frac{5.197}{1 - \left(\frac{I}{I_{\text{Threshold value I}}} \right)^{1.5625}} \cdot D \quad [s]$$

Note: I_{GNd} threshold stands for ground fault instead of the I threshold.

[Max: 9004-060210-01-NF 2. es: 1/14]

Figure 12-12 Operate Curves and Dropout-Time Characteristic Curves According to ANSI/IEEE

Frequency Operating Range

$0.9 \leq f/f_{\text{rated}} \leq 1.1$	According to specified tolerances
$10 \text{ Hz} < f < 0.9 f_{\text{rated}}$	Slightly expanded tolerances
$1.1 f_{\text{rated}} < f \leq 80 \text{ Hz}$	
$f < 10 \text{ Hz}$	Active
$f > 80 \text{ Hz}$	

Tolerances

3I0 measured via I4 ⁵⁴ , method of measurement = fundamental component	1 % of the setting value or 5 mA ($I_{\text{rated}} = 1 \text{ A}$) or 25 mA ($I_{\text{rated}} = 5 \text{ A}$), ($I_{\text{rated}} \pm 10 \%$)
3I0 measured via I4 ⁵⁵ , method of measurement = RMS value (33 % harmonics, in relation to fundamental component)	
Up to 30th harmonic	1 % of the setting value or 5 mA ($I_{\text{rated}} = 1 \text{ A}$) or 25 mA ($I_{\text{rated}} = 5 \text{ A}$), ($I_{\text{rated}} \pm 10 \%$)
Up to 50th harmonic, $f_{\text{rated}} = 50 \text{ Hz}$	3 % of the setting value or 20 mA ($I_{\text{rated}} = 1 \text{ A}$) or 100 mA ($I_{\text{rated}} = 5 \text{ A}$), ($I_{\text{rated}} \pm 10 \%$)
Up to 50th harmonic, $f_{\text{rated}} = 60 \text{ Hz}$	4 % of the setting value or 20 mA ($I_{\text{rated}} = 1 \text{ A}$) or 100 mA ($I_{\text{rated}} = 5 \text{ A}$), ($I_{\text{rated}} \pm 10 \%$)
Operate time for $2 \leq I/I_{\text{threshold value}} \leq 20$	5 % of the reference (calculated) value +2 % current tolerance or 30 ms

⁵⁴ Insignificantly increased tolerances will occur during the calculation of 3I0, maximum factor of 2

⁵⁵ Insignificantly increased tolerances will occur during the calculation of 3I0, maximum factor of 2

M. Pees

BA

[Handwritten signature]

Dropout time for $2 \leq I_{\text{threshold value}} \leq 0.90$	5 % of the reference (calculated) value ±2 % current tolerance or 30 ms
--	--

Influencing Variables for Thresholds

Transient excess pickup in method of measurement = fundamental component, for $\tau > 100$ ms (with complete unbalance)	< 5 %
---	-------

12.7.3 Stage with User-Defined Characteristic Curve

Setting Values

Method of measurement	Fundamental component	–
	RMS value	
Threshold value	1 A @ 50 and 100 Irated	0.030 A to 35.000 A Increments of 0.005 A
	5 A @ 50 and 100 Irated	0.15 A to 175.00 A Increments of 0.01 A
	1 A @ 1.6 Irated	0.001 A to 1.600 A Increments of 0.001 A
	5 A @ 1.6 Irated	0.005 A to 8.000 A Increments of 0.001 A
Dropout	Disk emulation Instantaneous	–
Time multiplier	0.05 to 15.00	Increments of 0.01
Number of value pairs for the operate curve	2 to 30	Increments of 1
X values of the operate curve	1.00 p.u. to 66.67 p.u.	Increments of 0.01 p.u.
Y values of the operate curve	0.00 s to 999.00 s	Increments of 0.01 s
Number of value pairs for the dropout characteristic curve	2 to 30	Increments of 1
X values of the dropout characteristic curve	0.05 p.u. to 0.95 p.u.	Increments of 0.01 p.u.
Y values of the dropout characteristic curve	0.00 s to 999.00 s	Increments of 0.01 s

Dropout

The greater dropout differential ($= | \text{pickup value} - \text{dropout value} |$) of the following 2 criteria applies:

Dropout	95 % of 1.1 · threshold value
Minimum absolute dropout differential	
Protection-class current transformer	15 mA sec. ($I_{\text{rated}} = 1$ A) or 75 mA sec. ($I_{\text{rated}} = 5$ A)
Instrument current transformer	0.5 mA sec. ($I_{\text{rated}} = 1$ A) or 2.5 mA sec. ($I_{\text{rated}} = 5$ A)

Reset of the Integration Timer

Instantaneous	With dropout
Disk emulation	Approx. < 0.90 · threshold value

Frequency Operating Range

$0.9 \leq f/f_{\text{rated}} \leq 1.1$	According to specified tolerances
$10 \text{ Hz} \leq f < 0.9 f_{\text{rated}}$	Slightly expanded tolerances
$1.1 f_{\text{rated}} < f \leq 80 \text{ Hz}$	

f < 10 Hz f > 80 Hz	Active
------------------------	--------

Tolerances

3I0 measured via I4 ⁵⁶ , method of measurement = fundamental component	± 1 % of the setting value or 5 mA (I _{rated} = 1 A) or 25 mA (I _{rated} = 5 A), (f _{rated} ± 10 %)
3I0 measured via I4 ⁵⁷ , method of measurement = RMS value (33 % harmonics, in relation to fundamental component)	
Up to 30th harmonic	1 % of the setting value or 5 mA (I _{rated} = 1 A) or 25 mA (I _{rated} = 5 A), (f _{rated} ± 10 %)
Up to 50th harmonic, f _{rated} = 50 Hz	3 % of the setting value or 20 mA (I _{rated} = 1 A) or 100 mA (I _{rated} = 5 A), (f _{rated} ± 10 %)
Up to 50th harmonic, f _{rated} = 60 Hz	4 % of the setting value or 20 mA (I _{rated} = 1 A) or 100 mA (I _{rated} = 5 A), (f _{rated} ± 10 %)
Operate time for I < I _l threshold value ≤ 20	5 % of the reference (calculated) value +2 % current tolerance or 30 ms
Dropout time for I _l threshold value ≤ 0,90	5 % of the reference (calculated) value +2 % current tolerance or 30 ms

Influencing Variables for Thresholds

Transient excess pickup in method of measurement = fundamental component, for τ > 100 ms (with complete unbalance)	< 5 %
--	-------

Operate Curves and Dropout-Time Characteristic Curves According to IEC

Extension of the operate time during operation with transformer inrush-current detection	Approx. 10 ms
--	---------------

⁵⁶ Insignificantly increased tolerances will occur during the calculation of 3I0, maximum factor of 2

⁵⁷ Insignificantly increased tolerances will occur during the calculation of 3I0, maximum factor of 2

A. Reed

12.8 Directional Overcurrent Protection, Phases



12.8.1 Stage with Definite-Time Characteristic Curve

Setting Values

Rotation angle of the reference voltage		-180° to +180°	Increments of 1°
Directional mode		Forward Reverse	-
Method of measurement		Fundamental component RMS value	--
Threshold value ⁵⁸	1 A @ 50 and 100 Irated	0.030 A to 35.000 A	Increments of 0.001 A
	5 A @ 50 and 100 Irated	0.15 A to 175.00 A	Increments of 0.01 A
	1 A @ 1.6 Irated	0.001 A to 1.600 A	Increments of 0.001 A
	5 A @ 1.6 Irated	0.005 A to 8.000 A	Increments of 0.001 A
Dropout ratio		0.90 to 0.99	Increments of 0.01
Time delay		0.00 s to 60.00 s	Increments of 0.01 s
Dropout delay		0.00 s to 60.00 s	Increments of 0.01 s

Dropout

The greater dropout differential (= | pickup value - dropout value |) of the following 2 criteria applies:

Dropout differential derived from the parameter Dropout ratio	
If this parameter is not available, a dropout ratio of 95 % applies for overcurrent and of 105 % for undercurrent functionality.	
Minimum absolute dropout differential	
Protection-class current transformer	15 mA sec. (I _{rated} = 1 A) or 75 mA sec. (I _{rated} = 5 A)
Instrument current transformer	0.5 mA sec. (I _{rated} = 1 A) or 2.5 mA sec. (I _{rated} = 5 A)

Direction Determination

Type	With externally generated voltages With voltage memory 2 s
Forward range	$V_{ref,rect} \pm 88^\circ$
Dropout differential forward/reverse range	1°
Directional sensitivity	Unlimited for 1 and 2-phase short circuits Dynamically unlimited, stationary for 3-phase short circuits Approx. 13 V phase-to-phase

Times

Operate time with Time Delay = 0 ms	Approx. 37 ms + OOT ⁵⁹ at 50 Hz Approx. 22 ms + OOT at 60 Hz
-------------------------------------	--



⁵⁸ If you have selected the method of measurement = RMS value, do not set the threshold value under $0.1 I_{rated,sec}$.

⁵⁹ OOT (Output Operating Time) additional delay of the output medium used, for example 5 ms with fast relays

A. Beck



Extension of the operate time during operation with transformer inrush-current detection	Approx. 10 ms
Dropout time	Approx. 20 ms + OOT

Frequency Operating Range

$0.9 \leq f/f_{rated} \leq 1.1$	According to specified tolerances
$10 \text{ Hz} \leq f < 0.9 f_{rated}$ $1.1 f_{rated} < f \leq 80 \text{ Hz}$	Slightly expanded tolerances
$f < 10 \text{ Hz}$ $f > 80 \text{ Hz}$	Active

Tolerances

Currents, method of measurement = fundamental component	1 % of the setting value or 5 mA ($I_{rated} = 1 \text{ A}$) or 25 mA ($I_{rated} = 5 \text{ A}$), ($f_{rated} \pm 10 \%$)
Currents, method of measurement = RMS value (33 % harmonics, in relation to fundamental component)	
Up to 30th harmonic	1 % of the setting value or 5 mA ($I_{rated} = 1 \text{ A}$) or 25 mA ($I_{rated} = 5 \text{ A}$), ($f_{rated} \pm 10 \%$)
Up to 50th harmonic, $f_{rated} = 50 \text{ Hz}$	3 % of the setting value or 20 mA ($I_{rated} = 1 \text{ A}$) or 100 mA ($I_{rated} = 5 \text{ A}$), ($f_{rated} \pm 10 \%$)
Up to 50th harmonic, $f_{rated} = 60 \text{ Hz}$	4 % of the setting value or 20 mA ($I_{rated} = 1 \text{ A}$) or 100 mA ($I_{rated} = 5 \text{ A}$), ($f_{rated} \pm 10 \%$)
Time delay	1 % of the setting value or 10 ms
Direction-determination angle error	1 °

Influencing Variables for Thresholds

Transient excess pickup in method of measurement = fundamental component, for $t > 100 \text{ ms}$ (with complete unbalance)	< 5 %
--	-------

12.8.2 Stage with Inverse-Time Characteristic Curve

Setting Values

Rotation angle of the reference voltage	-180° to +180°	Increments of 1°	
Directional mode	Forward Backward	-	
Method of measurement	Fundamental component RMS value	-	
Threshold value ⁶²	1 A @ 50 and 100 Irated	0.030 A to 35.000 A	Increments of 0.001 A
	5 A @ 50 and 100 Irated	0.15 A to 175.00 A	Increments of 0.01 A
	1 A @ 1.6 Irated	0.001 A to 1.600 A	Increments of 0.001 A
	5 A @ 1.6 Irated	0.005 A to 8.000 A	Increments of 0.001 A
Dropout	Disk emulation	-	
	Instantaneous	-	

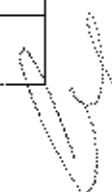

⁶² If you have selected the method of measurement = RMS value, do not set the threshold value under $0.1 I_{rated,sec}$

A. P. ...

Time multiplier	0.00 to 15.00	Increments of 0.01
Minimum time of the curve	0.00 s to 1.00 s	Increments of 0.01 s
Additional time delay	0.00 s to 60.00 s	Increments of 0.01 s

Dropout

The greater dropout differential (= | pickup value - dropout value |) of the following 2 criteria applies:

Dropout	95 % of 1.1 · threshold value
Minimum absolute dropout differential	
Protection-class current transformer	35 mA sec. ($I_{rated} = 1 \text{ A}$) or 75 mA sec. ($I_{rated} = 5 \text{ A}$)
Instrument current transformer	0.5 mA sec. ($I_{rated} = 1 \text{ A}$) or 2.5 mA sec. ($I_{rated} = 5 \text{ A}$)

Reset of the Integration Timer

Instantaneous	With dropout
Disk emulation	Approx. $< 0.90 \cdot$ threshold value

Operate Curves and Dropout-Time Characteristic Curves according to IEC

Normal inverse: type A	See chapter 12.5.2 Stage with Inverse-Time Characteristic Curve, Figure 12-1
Very inverse: type B	
Extremely inverse: type C	See chapter 12.5.2 Stage with inverse-Time Characteristic Curve, Figure 12-2
Long-time inverse: type B	

Operate Curves and Dropout-Time Characteristic Curves according to ANSI/IEEE

Inverse: type C	See chapter 12.5.2 Stage with Inverse-Time Characteristic Curve, Figure 12-3
Short inverse	
Long Inverse	See chapter 12.5.2 Stage with Inverse-Time Characteristic Curve, Figure 12-4
Moderately inverse	
Very Inverse	See chapter 12.5.2 Stage with Inverse-Time Characteristic Curve, Figure 12-5
Extremely inverse	
Definite Inverse	See chapter 12.5.2 Stage with Inverse-Time Characteristic Curve, Figure 12-6

Direction Determination

Type	With externally generated voltages With voltage memory 2 s
Forward range	$V_{ref,rot} + 88^\circ$
Dropout differential forward/reverse range	1°
Directional sensitivity	Unlimited for 1 and 2-phase short circuits Dynamically unlimited, stationary for 3-phase short circuits Approx. 13 V phase-to-phase

Times

Operate time with time delay = 0 ms	Approx. 37 ms + OOT ⁶¹ at 50 Hz Approx. 22 ms + OOT at 60 Hz
Extension of the operate time during operation with transformer inrush-current detection	Approx. 10 ms
Dropout time	Approx. 20 ms + OOT

Frequency Operating Range

$0.9 \leq f/f_{rated} \leq 1.1$	According to specified tolerances
$10 \text{ Hz} \leq f < 0.9 f_{rated}$ $1.1 f_{rated} < f \leq 80 \text{ Hz}$	Slightly expanded tolerances
$f < 10 \text{ Hz}$ $f > 80 \text{ Hz}$	Active

Tolerances

Currents, method of measurement = fundamental component	± % of the setting value or 5 mA ($I_{rated} = 1 \text{ A}$) or 25 mA ($I_{rated} = 5 \text{ A}$), ($f_{rated} \pm 10 \%$)
Currents, method of measurement = RMS value (33 % harmonics, in relation to fundamental component)	
Up to 30th harmonic	1 % of the setting value or 5 mA ($I_{rated} = 1 \text{ A}$) or 25 mA ($I_{rated} = 5 \text{ A}$), ($f_{rated} \pm 10 \%$)
Up to 50th harmonic, $f_{rated} = 50 \text{ Hz}$	3 % of the setting value or 20 mA ($I_{rated} = 1 \text{ A}$) or 100 mA ($I_{rated} = 5 \text{ A}$), ($f_{rated} \pm 10 \%$)
Up to 50th harmonic, $f_{rated} = 60 \text{ Hz}$	4 % of the setting value or 20 mA ($I_{rated} = 1 \text{ A}$) or 100 mA ($I_{rated} = 5 \text{ A}$), ($f_{rated} \pm 10 \%$)
Operate time for $2 \leq I/I$ threshold value ≤ 20	5 % of the reference (calculated) value +2 % current tolerance or 10 ms
Dropout time for I/I threshold value ≤ 0.90	5 % of the reference (calculated) value +2 % current tolerance or 10 ms
Direction-determination angle error	1°

Influencing Variables for Thresholds

Transient excess pickup in method of measurement – fundamental component, for $t > 100 \text{ ms}$ (with complete unbalance)	< 5 %
--	-------

12.8.3 Stage with User-Defined Characteristic Curve

Setting Values

Rotation angle of the reference voltage	-180° to +180°	Increments of 1°
Directional mode	Forward Reverse	–
Method of measurement	Fundamental component RMS value	–

⁶¹ OOT (Output Operating Time) additional delay of the output medium used, for example 5 ms with fast relays



Threshold value ⁶²	1 A @ 50 and 100 Irated	0.030 A to 35.000 A	Increments of 0.001 A
	5 A @ 50 and 100 Irated	0.15 A to 175.00 A	Increments of 0.01 A
	1 A @ 1.6 Irated	0.001 A to 1.600 A	Increments of 0.001 A
	5 A @ 1.6 Irated	0.005 A to 8.000 A	increments of 0.001 A
Dropout		Disk emulation Instantaneous	
Time multiplier		0.05 to 15.00	Increments of 0.01
Number of value pairs for the operate characteristic curve		2 to 30	Increments of 1
X values of the operate curve		1.00 p.u. to 66.67 p.u.	Increments of 0.01 p.u.
Y values of the operate curve		0.00 s to 999.00 s	Increments of 0.01 s
Number of value pairs for the dropout characteristic curve		2 to 30	Increments of 1
X values of the dropout characteristic curve		0.05 p.u. to 0.95 p.u.	Increments of 0.01 p.u.
Y values of the dropout characteristic curve		0.00 s to 999.00 s	Increments of 0.01 s

Dropout

The greater dropout differential (= | pickup value - dropout value |) of the following 2 criteria applies:

Dropout	95 % of 1.1 · threshold value
Minimum absolute dropout differential	
Protection-class current transformer	15 mA sec. ($I_{rated} = 1 A$) or 75 mA sec. ($I_{rated} = 5 A$)
Instrument current transformer	0.5 mA sec. ($I_{rated} = 1 A$) or 2.5 mA sec. ($I_{rated} = 5 A$)

Reset of the Integration Timer

instantaneous	With dropout
Disk emulation	Approx. < 0.90 · threshold value

Direction Determination

Type	With externally generated voltages With voltage memory 2 s
Forward range	$V_{rel,act} \pm 88^\circ$
Dropout differential forward/reverse range	1°
Directional sensitivity	Unlimited for 1 and 2-phase short circuits Dynamically unlimited, stationary for 3-phase short circuits Approx. 13 V phase-to-phase

Times

Operate time with time delay = 0 ms	Approx. 37 ms + OOT ⁶³ at 50 Hz Approx. 22 ms + OOT at 60 Hz
Extension of the operate time during operation with transformer inrush-current detection	Approx. 10 ms

⁶² If you have selected the method of measurement – RMS value, do not set the threshold value under $0.1 I_{rated,sec}$

⁶³ OOT (Output Operating Time) additional delay of the output medium used, for example 5 ms with fast relays

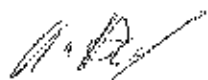
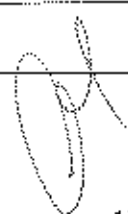

Dropout time	Approx. 20 ms + OOT
--------------	---------------------

Frequency Operating Range

$0.9 \leq f/f_{rated} \leq 1.1$	According to specified tolerances
$10 \text{ Hz} \leq f < 0.9 f_{rated}$ $1.1 f_{rated} < f \leq 80 \text{ Hz}$	Slightly expanded tolerances
$f < 10 \text{ Hz}$ $f > 80 \text{ Hz}$	Active

Tolerances

Currents, method of measurement = fundamental component	1 % of the setting value or 5 mA ($I_{rated} = 1 \text{ A}$) or 25 mA ($I_{rated} = 5 \text{ A}$), ($f_{rated} \pm 10 \%$)
Currents, method of measurement = RMS value (33 % harmonics, in relation to fundamental component)	
Up to 30th harmonic	3 % of the setting value or 5 mA ($I_{rated} = 1 \text{ A}$) or 25 mA ($I_{rated} = 5 \text{ A}$), ($f_{rated} \pm 10 \%$)
Up to 50th harmonic, $f_{rated} = 50 \text{ Hz}$	3 % of the setting value or 20 mA ($I_{rated} = 1 \text{ A}$) or 100 mA ($I_{rated} = 5 \text{ A}$), ($f_{rated} \pm 10 \%$)
Up to 50th harmonic, $f_{rated} = 60 \text{ Hz}$	4 % of the setting value or 20 mA ($I_{rated} = 1 \text{ A}$) or 100 mA ($I_{rated} = 5 \text{ A}$), ($f_{rated} \pm 10 \%$)
Operate time for $2 \leq I/I$ threshold value ≤ 20	5 % of the reference (calculated) value +2 % current tolerance or 10 ms
Dropout time for I/I threshold value ≤ 0.90	5 % of the reference (calculated) value +2 % current tolerance or 10 ms
Direction determination angle error	$\leq 0^\circ$

Influencing Variables for Thresholds

Transient excess pickup in method of measurement = fundamental component, for $\tau > 100 \text{ ms}$ (with complete unbalance)	$< 5 \%$
---	----------

12.9 Directional Overcurrent Protection, Ground



12.9.1 Stage with Definite-Time Characteristic Curve

Setting Values for the Function Direction Determination

Method for direction determination	Zero sequence Negative sequence	–
Minimum V0 or V2 threshold	0.150 V to 20.000 V	0.001 V
Rotation angle of the reference voltage	-180° to 180°	1°
Forward range	0° to 180°	1°

Setting Values

Direction mode	Forward Reverse	–	
Method of measurement	Fundamental component RMS value	–	
Threshold value	1 A @ 50 and 100 Irated	0.030 A to 35.000 A	Increments of 0.001 A
	5 A @ 50 and 100 Irated	0.15 A to 175.00 A	Increments of 0.01 A
	1 A @ 1.6 Irated	0.001 A to 1.600 A	Increments of 0.001 A
	5 A @ 1.6 Irated	0.005 A to 8.000 A	Increments of 0.001 A
Dropout ratio	0.90 to 0.99	Increments of 0.01	
Operate delay	0.00 s to 60.00 s	Increments of 0.01 s	
Dropout delay	0.00 s to 60.00 s	Increments of 0.01 s	

Dropout

The greater dropout differential (– | pickup value – dropout value |) of the following 2 criteria applies:

Dropout differential derived from the parameter Dropout ratio If this parameter is not available, a dropout ratio of 95 % applies for overcurrent and of 105 % for undercurrent functionality.	
Minimum absolute dropout differential	
Protection-class current transformer	15 mA sec. (I _{rated} = 1 A) or 75 mA sec. (I _{rated} = 5 A)
Instrument current transformer	0.5 mA sec. (I _{rated} = 1 A) or 2.5 mA sec. (I _{rated} = 5 A)

Times

The maximum pickup time with operate delay = 0 ms	Approx. 30 ms + OOT at 50 Hz Approx. 25 ms + OOT at 60 Hz
Extension of the operate time during operation with inrush-current detection	Approx. 10 ms
Dropout time	Approx. 20 ms + OOT

Frequency Operating Range

$0.9 < f/f_{rated} \leq 1.1$	According to specified tolerances
------------------------------	-----------------------------------

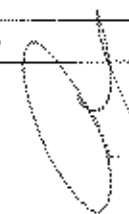

Handwritten signature or mark at the bottom left corner.

$10 \text{ Hz} \leq f < 0.9 f_{\text{rated}}$ $1.1 f_{\text{rated}} < f \leq 80 \text{ Hz}$	Slightly expanded tolerances
$f < 10 \text{ Hz}$ $f > 80 \text{ Hz}$	Active with reduced sensitivity

Tolerances

Currents, method of measurement = fundamental component	1 % of the setting value or 5 mA ($I_{\text{rated}} = 1 \text{ A}$) or 25 mA ($I_{\text{rated}} = 5 \text{ A}$)
Currents, method of measurement = RMS value (33 % part of harmonic, referring to fundamental component)	
Up to 30th harmonic	1 % of the setting value or 5 mA ($I_{\text{rated}} = 1 \text{ A}$) or 25 mA ($I_{\text{rated}} = 5 \text{ A}$), ($f_{\text{rated}} \pm 10 \%$)
Up to 50th harmonic, $f_{\text{rated}} = 50 \text{ Hz}$	3 % of the setting value or 20 mA ($I_{\text{rated}} = 1 \text{ A}$) or 100 mA ($I_{\text{rated}} = 5 \text{ A}$), ($f_{\text{rated}} \pm 10 \%$)
Up to 50th harmonic, $f_{\text{rated}} = 60 \text{ Hz}$	4 % of the setting value or 20 mA ($I_{\text{rated}} = 1 \text{ A}$) or 100 mA ($I_{\text{rated}} = 5 \text{ A}$), ($f_{\text{rated}} \pm 10 \%$)
Time delays	1 % of the setting value or 10 ms
Direction-determination angle error	1°

Influencing Variables for Thresholds

Transient excess pickup in method of measurement = fundamental component, for $\tau > 100 \text{ ms}$ (with complete unbalance)	< 5 %
---	-------

12.9.2 Stage with Inverse-Time Characteristic Curve

Setting Values for the Function Direction Determination

Method for direction determination	Zero sequence Negative sequence	
Minimum V0 or V2 threshold	0.150 V to 20.000 V	0.001 V
Rotation angle of the reference voltage	-180° to 180°	1°
Forward range	0° to 180°	1°

Setting Values

Direction mode	Forward Reverse	-	
Method of measurement	Fundamental component RMS value	-	
Threshold value	1 A @ 50 and 100 Irated	0.030 A to 35.000 A	Increments of 0.001 A
	5 A @ 50 and 100 Irated	0.15 A to 175.00 A	increments of 0.01 A
	1 A @ 1.6 Irated	0.001 A to 1.600 A	increments of 0.001 A
	5 A @ 1.6 Irated	0.005 A to 8.000 A	increments of 0.001 A
Type of characteristic curve	Characteristic curves according to IEC and ANSI		
Dropout	Disk emulation Instantaneous		
Time multiplier	0.00 to 15.00	increments of 0.01	

Minimum time of the curve	0.00 s to 1.00 s	Increments of 0.01 s
Additional time delay	0.00 s to 60.00 s	Increments of 0.01 s

Dropout

The greater dropout differential (= | pickup value - dropout value |) of the following 2 criteria applies:

Dropout	95 % of 1.1 · threshold value
Minimum absolute dropout differential	
Protection-class current transformer	15 mA sec. ($I_{rated} = 1\text{ A}$) or 75 mA sec. ($I_{rated} = 5\text{ A}$)
Instrument current transformer	0.5 mA sec. ($I_{rated} = 1\text{ A}$) or 2.5 mA sec. ($I_{rated} = 5\text{ A}$)

Reset of the Integration Timer

Instantaneous	With dropout
Disk emulation	Approx. $< 0.90 \cdot$ threshold value

Operate Curves and Dropout-Time Characteristic Curves according to IEC

Normal inverse: type A	Refer to the respective figure of the technical data for the non-dir-OC-ground function 12.7.2 Stage with Inverse-Time Characteristic Curve
Very inverse: type B	
Extremely inverse: type C	
Long-time inverse: type D	

Operate Curves and Dropout-Time Characteristic Curves according to ANSI/IEEE

Inverse: type C	Refer to the respective figure of the technical data for the non-dir-OC-ground function 12.7.2 Stage with Inverse-Time Characteristic Curve
Short inverse	
Long inverse	
Moderately inverse	
Very inverse	
Extremely inverse	
Definite inverse	

Times

The maximum pickup time with operate delay = 0 ms	Approx. 30 ms + OOT at 50 Hz Approx. 25 ms + OOT at 60 Hz
Extension of the operate time during operation with inrush-current detection	Approx. 10 ms
Dropout time	Approx. 20 ms + OOT

Frequency Operating Range

$0.9 \leq f/f_{rated} \leq 1.1$	According to specified tolerances
$10\text{ Hz} \leq f < 0.9 f_{rated}$	Slightly expanded tolerances
$1.1 f_{rated} < f < 80\text{ Hz}$	Active with reduced sensitivity
$f < 10\text{ Hz}$ $f > 80\text{ Hz}$	

A. Roux



Tolerances

Currents, method of measurement = fundamental component	1 % of the setting value or 5 mA ($I_{rated} = 1 A$) or 25 mA ($I_{rated} = 5 A$)
Currents, method of measurement = RMS value (33 % part of harmonic, referring to fundamental component)	
Up to 30th harmonic	1 % of the setting value or 5 mA ($I_{rated} = 1 A$) or 25 mA ($I_{rated} = 5 A$), ($f_{rated} \pm 10 \%$)
Up to 50th harmonic, $f_{rated} = 50 Hz$	3 % of the setting value or 20 mA ($I_{rated} = 1 A$) or 100 mA ($I_{rated} = 5 A$), ($f_{rated} \pm 10 \%$)
Up to 50th harmonic, $f_{rated} = 60 Hz$	4 % of the setting value or 20 mA ($I_{rated} = 1 A$) or 100 mA ($I_{rated} = 5 A$), ($f_{rated} \pm 10 \%$)
Operate time for $2 < I/I$ threshold value ≤ 20	5 % of the reference (calculated) value + 2 % current tolerance or 30 ms
Dropout time for I/I threshold value ≤ 0.90	5 % of the reference (calculated) value + 2 % current tolerance or 30 ms
Direction-determination angle error	1°

Influencing Variables for Thresholds

Transient excess pickup in method of measurement = fundamental component, for $\tau > 100 ms$ (with complete unbalance)	$< 5 \%$
---	----------

12.9.3 Stage with Inverse Time-Overcurrent Protection with Logarithmic-Inverse Characteristic Curve

Setting Values for the Function Direction Determination

Method for direction determination	Zero sequence Negative sequence	--
Minimum V0 or V2 threshold	0.150 V to 20.000 V	0.001 V
Rotation angle of the reference voltage	-180° to 180°	1°
Forward range	0° to 180°	1°

Setting Values

Direction mode	Forward Reverse	--	
Method of measurement	Fundamental component RMS value	--	
Threshold value	1 A @ 50 and 100 Irated	0.030 A to 35.000 A	increments of 0.001 A
	5 A @ 50 and 100 Irated	0.15 A to 175.00 A	increments of 0.01 A
	1 A @ 1.6 Irated	0.001 A to 1.600 A	increments of 0.001 A
	5 A @ 1.6 Irated	0.005 A to 8.000 A	increments of 0.001 A
Characteristic curve: see <i>Figure 12-13</i>			
Threshold value multiplier	1.00 to 4.00	increments of 0.01	
Time multiplier	0.000 s to 60.000 s	increments of 0.001 s	
Minimum time of the characteristic curve	0.000 s to 60.000 s	increments of 0.001 s	
Maximum time of the characteristic curve	0.000 s to 60.000 s	increments of 0.001 s	

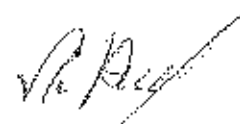
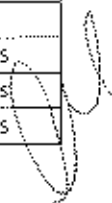

Additional time delay	0.000 s to 60.000 s	Increments of 0.001 s
-----------------------	---------------------	-----------------------

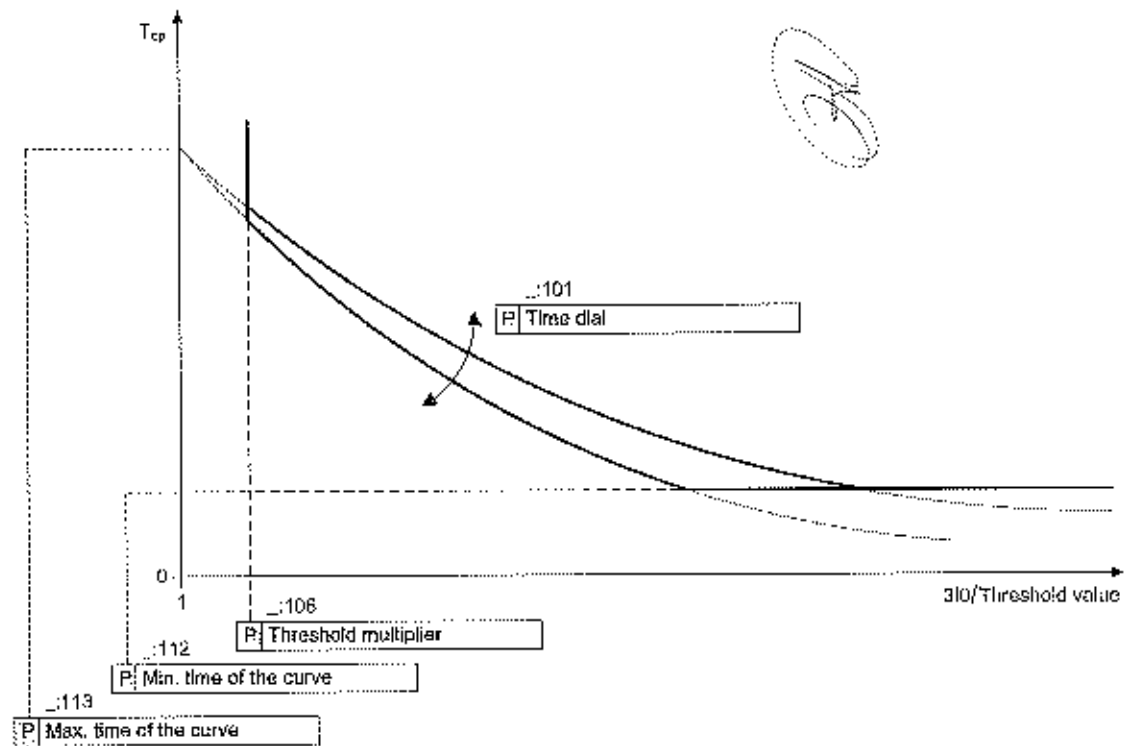

[Note: for 3DDE/3, 3, on_06]

Figure 12-13 Operate Curve of Logarithmic Inverse-Time Characteristic

Dropout

The greater dropout differential ($= | \text{pickup value} - \text{dropout value} |$) of the following 2 criteria applies:

Dropout differential derived from the parameter Dropout ratio	
If this parameter is not available, a dropout ratio of 95 % applies for overcurrent and of 105 % for undercurrent functionality.	
Minimum absolute dropout differential	
Protection-class current transformer	15 mA sec. ($I_{rated} = 1 \text{ A}$) or 75 mA sec. ($I_{rated} = 5 \text{ A}$)
Instrument current transformer	0.5 mA sec. ($I_{rated} = 1 \text{ A}$) or 2.5 mA sec. ($I_{rated} = 5 \text{ A}$)

Times

The maximum pickup time with operate delay $\approx 0 \text{ ms}$	Approx. 30 ms + OOT at 50 Hz Approx. 25 ms + OOT at 60 Hz
Extension of the operate time during operation with inrush-current detection	Approx. 30 ms
Dropout time	Approx. 20 ms + OOT

Frequency Operating Range

$0.9 < f/f_{rated} \leq 1.1$	According to specified tolerances
------------------------------	-----------------------------------

Handwritten signature

Handwritten signature

$10 \text{ Hz} \leq f < 0.9 f_{\text{rated}}$ $1.1 f_{\text{rated}} < f \leq 80 \text{ Hz}$	Slightly expanded tolerances
$f < 10 \text{ Hz}$ $f > 80 \text{ Hz}$	Active with reduced sensitivity

Tolerances

Currents, method of measurement = fundamental component	1 % of the setting value or 5 mA ($I_{\text{rated}} = 1 \text{ A}$) or 25 mA ($I_{\text{rated}} = 5 \text{ A}$)
Currents, method of measurement = RMS value (33 % part of harmonic, referring to fundamental component)	
Up to 30th harmonic	1 % of the setting value or 5 mA ($I_{\text{rated}} = 1 \text{ A}$) or 25 mA ($I_{\text{rated}} = 5 \text{ A}$), ($f_{\text{rated}} \pm 10 \%$)
Up to 50th harmonic, $f_{\text{rated}} = 50 \text{ Hz}$	3 % of the setting value or 20 mA ($I_{\text{rated}} = 1 \text{ A}$) or 100 mA ($I_{\text{rated}} = 5 \text{ A}$), ($f_{\text{rated}} \pm 10 \%$)
Up to 50th harmonic, $f_{\text{rated}} = 60 \text{ Hz}$	4 % of the setting value or 20 mA ($I_{\text{rated}} = 1 \text{ A}$) or 100 mA ($I_{\text{rated}} = 5 \text{ A}$), ($f_{\text{rated}} \pm 10 \%$)
Inverse-time operate time to logarithmic inverse-time characteristic	5 % of the reference (calculated) value + 2 % current tolerance or 30 ms
Inverse-time dropout time to logarithmic inverse-time characteristic	5 % of the reference (calculated) value + 2 % current tolerance or 30 ms
Direction-determination angle error	1°

Influencing Variables for Thresholds

Transient excess pickup in method of measurement – fundamental component, for $t > 100 \text{ ms}$ (with complete unbalance)	< 5 %
--	-------

12.9.4 Stage with Knee-Point Characteristic Curve

Setting Values for the Function Direction Determination

Method for direction determination	Zero sequence Negative sequence	–
Minimum V0 or V2 threshold	0.150 V to 20.000 V	0.001 V
Rotation angle of the reference voltage	-180° to 180°	1°
Forward range	0° to 180°	1°

Setting Values

Direction mode	Forward Reverse	–	
Method of measurement	Fundamental component RMS value		
Threshold value	1 A @ 50 and 100 Irated	0.030 A to 35.000 A	Increments of 0.001 A
	5 A @ 50 and 100 Irated	0.15 A to 175.00 A	Increments of 0.01 A
	1 A @ 1.6 Irated	0.001 A to 1.600 A	Increments of 0.001 A
	5 A @ 1.6 Irated	0.005 A to 8.000 A	Increments of 0.001 A

Handwritten signature

Handwritten signature

Characteristic curve; see Figure 12-14		
Minimum time of the characteristic curve	0.00 s to 30.00 s	Increments of 0.01 s
Knee-point time of the curve	0.00 s to 100.00 s	Increments of 0.01 s
Maximum time of the characteristic curve	0.00 s to 200.00 s	Increments of 0.01 s
Knee-point value	0.030 A to 35.000 A	Increments of 0.001 A
Current at minimum time of the curve	0.030 A to 35.000 A	Increments of 0.001 A
Time multiplier	0.05 to 1.50	Increments of 0.01

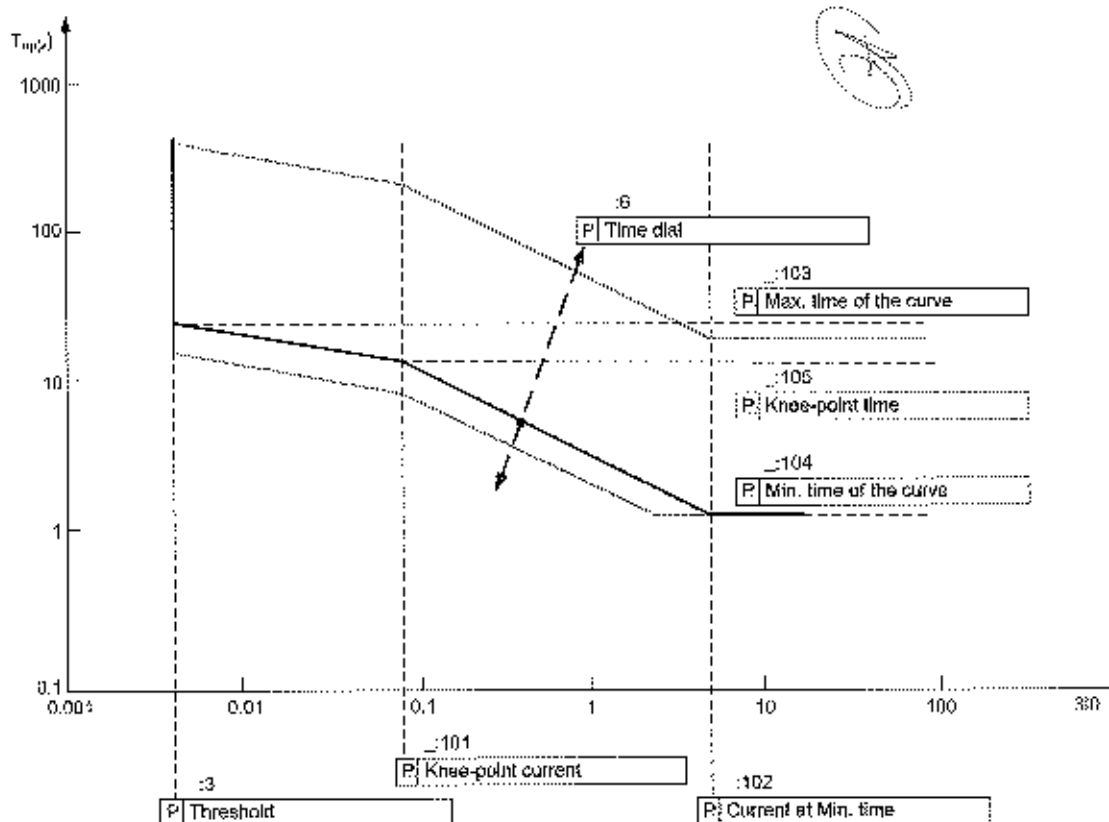

Legend: (1) 1013, 1, on US

Figure 12-14 Operate Curve of the Logarithmic Inverse Time with Knee-Point Characteristic (In the Example of **Threshold = 0.004 A**)

Dropout

The greater dropout differential (= | pickup value - dropout value |) of the following 2 criteria applies:

Dropout differential derived from the parameter Dropout ratio	
If this parameter is not available, a dropout ratio of 95 % applies for overcurrent and of 105 % for undercurrent functionality.	
Minimum absolute dropout differential	
Protection-class current transformer	15 mA sec. ($I_{rated} = 1 A$) or 75 mA sec. ($I_{rated} = 5 A$)
Instrument current transformer	0.5 mA sec. ($I_{rated} = 1 A$) or 2.5 mA sec. ($I_{rated} = 5 A$)

A. Riedel

Times

The maximum pickup time with operate delay = 0 ms	Approx. 30 ms + OOT at 50 Hz Approx. 25 ms + OOT at 60 Hz
Extension of the operate time during operation with inrush-current detection	Approx. 10 ms
Dropout time	Approx. 20 ms + OOT

Frequency Operating Range

$0.9 < f/f_{rated} \leq 1.1$	According to specified tolerances
$10 \text{ Hz} \leq f < 0.9 f_{rated}$ $1.1 f_{rated} < f \leq 80 \text{ Hz}$	Slightly expanded tolerances
$f < 10 \text{ Hz}$ $f > 80 \text{ Hz}$	Active with reduced sensitivity

Tolerances

Currents, method of measurement – fundamental component	± % of the setting value or 5 mA ($I_{rated} = 1 \text{ A}$) or 25 mA ($I_{rated} = 5 \text{ A}$)
Currents, method of measurement – RMS value (33 % part of harmonic, referring to fundamental component)	
Up to 30th harmonic	1 % of the setting value or 5 mA ($I_{rated} = 1 \text{ A}$) or 25 mA ($I_{rated} = 5 \text{ A}$), ($f_{rated} \pm 10 \%$)
Up to 50th harmonic, $f_{rated} = 50 \text{ Hz}$	3 % of the setting value or 20 mA ($I_{rated} = 1 \text{ A}$) or 100 mA ($I_{rated} = 5 \text{ A}$), ($f_{rated} \pm 10 \%$)
Up to 50th harmonic, $f_{rated} = 60 \text{ Hz}$	4 % of the setting value or 20 mA ($I_{rated} = 1 \text{ A}$) or 100 mA ($I_{rated} = 5 \text{ A}$), ($f_{rated} \pm 10 \%$)
Inverse time operate time to logarithmic inverse time with knee-point characteristic	5 % of the reference (calculated) value + 2 % current tolerance or 30 ms
Inverse-time dropout time to logarithmic inverse time with knee-point characteristic	5 % of the reference (calculated) value + 2 % current tolerance or 30 ms
Direction-determination angle error	1°

Influencing Variables for Thresholds

Transient excess pickup in method of measurement – fundamental component, for $t > 100 \text{ ms}$ (with complete unbalance)	< 5 %
--	-------

12.9.5 Stage with User-Defined Characteristic Curve

Setting Values for the Function Direction Determination

Method for direction determination	Zero sequence Negative sequence	–
Minimum V0 or V2 threshold	0.150 V to 20.000 V	0.001 V
Rotation angle of the reference voltage	-180° to 180°	1°
Forward range	0° to 180°	1°

Setting Values

Direction mode		Forward Reverse	–
Method of measurement		Fundamental component RMS value	–
Threshold value	1 A @ 50 and 100 Irated	0.030 A to 35.000 A	Increments of 0.001 A
	5 A @ 50 and 100 Irated	0.15 A to 175.00 A	Increments of 0.01 A
	3 A @ 1.6 Irated	0.001 A to 1.600 A	Increments of 0.001 A
	5 A @ 1.6 Irated	0.005 A to 8.000 A	Increments of 0.001 A
Dropout		Disk emulation Instantaneous	–
Time multiplier		0.05 to 15.00	Increments of 0.01
X values of the operate curve		1.00 p. u. to 66.67 p. u.	Increments of 0.01 p. u.
Y values of the operate curve		0.00 s to 999.00 s	Increments of 0.01 s
Number of value pairs for the dropout characteristic curve		2 to 30	increments of 1
X values of the dropout characteristic curve		0.05 p. u. to 0.95 p. u.	Increments of 0.01 p. u.
Y values of the dropout characteristic curve		0.00 s to 999.00 s	Increments of 0.01 s

Dropout

The greater dropout differential (– pickup value – dropout value) of the following 2 criteria applies:

Dropout	95 % of 1.1 · threshold value
Minimum absolute dropout differential	
Protection-class current transformer	15 mA sec. ($I_{rated} = 1 A$) or 75 mA sec. ($I_{rated} = 5 A$)
Instrument current transformer	0.5 mA sec. ($I_{rated} = 3 A$) or 2.5 mA sec. ($I_{rated} = 5 A$)

Reset of the Integration Timer

Instantaneous	With dropout
Disk emulation	Approx. $< 0.90 \cdot$ threshold value

Times

The maximum pickup time with operate delay = 0 ms	Approx. 30 ms + OOT at 50 Hz Approx. 25 ms + OOT at 60 Hz
Extension of the operate time during operation with inrush-current detection	Approx. 10 ms
Dropout time	Approx. 20 ms + OOT

Frequency Operating Range

$0.9 \leq f/f_{rated} \leq 1.1$	According to specified tolerances
$10 \text{ Hz} \leq f < 0.9 f_{rated}$ $1.1 f_{rated} < f \leq 80 \text{ Hz}$	Slightly expanded tolerances
$f < 10 \text{ Hz}$ $f > 80 \text{ Hz}$	Active with reduced sensitivity

Handwritten signature

Handwritten signature



Tolerances

Currents, method of measurement = fundamental component	1 % of the setting value or 5 mA ($I_{rated} = 1 A$) or 25 mA ($I_{rated} = 5 A$)
Currents, method of measurement = RMS value (33 % part of harmonic, referring to fundamental component)	
Up to 30th harmonic	1 % of the setting value or 5 mA ($I_{rated} = 1 A$) or 25 mA ($I_{rated} = 5 A$), ($f_{rated} \pm 10 \%$)
Up to 50th harmonic, $f_{rated} = 50 Hz$	3 % of the setting value or 20 mA ($I_{rated} = 1 A$) or 100 mA ($I_{rated} = 5 A$), ($f_{rated} \pm 10 \%$)
Up to 50th harmonic, $f_{rated} = 60 Hz$	4 % of the setting value or 20 mA ($I_{rated} = 1 A$) or 100 mA ($I_{rated} = 5 A$), ($f_{rated} \pm 10 \%$)
Operate time for $2 \leq I/I$ threshold value ≤ 20	5 % of the reference (calculated) value + 2 % current tolerance or 30 ms
Dropout time for I/I threshold value ≤ 0.90	5 % of the reference (calculated) value + 2 % current tolerance or 30 ms
Direction-determination angle error	1°

Influencing Variables for Thresholds

Transient excess pickup in method of measurement = fundamental component, for $\tau > 100 ms$ (with complete unbalance)	< 5 %
---	-------



12.10 Inrush-Current Detection

Setting Values

Operat. range limit I_{max}	1 A @ 50 and 100 Irated	0.030 A to 35.000 A	Increments of 0.001 A
	5 A @ 50 and 100 Irated	0.15 A to 175.00 A	Increments of 0.01 A
	1 A @ 1.6 Irated	0.001 A to 1.600 A	Increments of 0.001 A
	5 A @ 1.6 Irated	0.005 A to 8.000 A	Increments of 0.001 A
Component of 2nd harmonic		10 % to 45 %	Increments of 1 %
Duration of the crossblock function		0.03 s to 200.00 s	Increments of 0.01 s

Times

Pickup times	Approx. 29 ms
--------------	---------------

Dropout Ratios

Harmonic: $I_{2nd\ harm} / I_{1st\ harm}$	0.95
--	------

Dropout

The greater dropout differential (= | pickup value - dropout value |) of the following 2 criteria applies:

Dropout differential derived from the parameter Dropout ratio If this parameter is not available, a dropout ratio of 95 % applies for overcurrent and of 105 % for undercurrent functionality.	
Minimum absolute dropout differential	
Protection-class current transformer	15 mA sec. ($I_{rated} = 1\ A$) or 75 mA sec. ($I_{rated} = 5\ A$)
Instrument current transformer	0.5 mA sec. ($I_{rated} = 1\ A$) or 2.5 mA sec. ($I_{rated} = 5\ A$)

Frequency Operating Range

$0.9 < f / f_{rated} \leq 1.1$	According to specified tolerances
$10\ Hz \leq f < 0.9 f_{rated}$ $1.1 f_{rated} < f \leq 80\ Hz$	Slightly expanded tolerances
$f < 10\ Hz$ $f > 80\ Hz$	Inactive

Tolerances

Current measurement I_{max}	1 % of the setting value or 5 mA
Harmonic: $I_{2nd\ harm} / I_{1st\ harm}$	± 3 % of the setting value for settings of $I_{2nd\ harm} / I_{1st\ harm}$
Time delays	1 % of the setting value or 10 ms

12.11 Arc Protection



Setting Values

Threshold I>	1 A @ 50 and 100 Irated	0.030 A to 35.000 A	Increments of 0.001 A
	5 A @ 50 and 100 Irated	0.15 A to 175.00 A	Increments of 0.01 A
	1 A @ 1.6 Irated	0.001 A to 1.600 A	Increments of 0.001 A
	5 A @ 1.6 Irated	0.005 A to 8.000 A	Increments of 0.001 A
Threshold 3I0>>	1 A @ 50 and 100 Irated	0.030 A to 35.000 A	Increments of 0.001 A
	5 A @ 50 and 100 Irated	0.15 A to 175.00 A	Increments of 0.01 A
	1 A @ 1.6 Irated	0.001 A to 1.600 A	Increments of 0.001 A
	5 A @ 1.6 Irated	0.005 A to 8.000 A	Increments of 0.001 A
External trip initiation	yes no		
Operating mode	Light only Current and light		
Sensor	Point sensor Line sensor Custom		
Threshold light	-28.00 dB to 0.00 dB	Increments of 0.01	
Channel	Possible settings, application-dependent		

Dropout

The larger dropout differential ($- | \text{pickup threshold} - \text{dropout threshold} |$) of the following 2 criteria is used:

Dropout differential derived from the Dropout ratio parameter	
If this parameter is not available, a dropout ratio of 95 % applies to the overcurrent protection and a dropout ratio of 105 % applies to the undercurrent protection.	
Minimum absolute dropout differential	
Protection-class current transformers	15 mA sec. ($I_{rated} = 1 \text{ A}$) or 75 mA sec. ($I_{rated} = 5 \text{ A}$)
Instrument transformers	0.5 mA sec. ($I_{rated} = 1 \text{ A}$) or 2.5 mA sec. ($I_{rated} = 5 \text{ A}$)

Times

Shortest operate time Operating mode = light only	Approx. 2.6 ms + OOT ⁶⁾
Shortest operate time Operating mode = Current and light	Approx. 4.0 ms + OOT at 50 Hz Approx. 3.8 ms + OOT at 60 Hz

⁶⁾ OOT (Output Operating Time) Additional delay of the output medium used, for example 5 ms with a fast relay, see Chapter 12.1.4 Relay Outputs

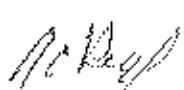

12.12 Instantaneous High-Current Tripping

Setting Values

Threshold value	1 A @ 100 I _{rated}	0.030 A to 35.000 A	Increments of 0.001 A
	5 A @ 100 I _{rated}	0.15 A to 175.00 A	Increments of 0.01 A
	1 A @ 50 I _{rated}	0.030 A to 35.000 A	Increments of 0.001 A
	5 A @ 50 I _{rated}	0.15 A to 175.00 A	Increments of 0.01 A
	1 A @ 1.6 I _{rated}	0.001 A to 1.600 A	Increments of 0.001 A
	5 A @ 1.6 I _{rated}	0.005 A to 8.000 A	Increments of 0.001 A
Dropout ratio		0.50 to 0.90	Increments of 0.01

Dropout

The greater dropout differential ($= | \text{pickup value} - \text{dropout value} |$) of the following 2 criteria applies:

Dropout differential derived from the parameter Dropout ratio If this parameter is not available, a dropout ratio of 95 % applies for overcurrent and of 105 % for undercurrent functionality.	
Minimum absolute dropout differential	
Protection-class current transformer	15 mA sec. (I _{rated} = 1 A) or 75 mA sec. (I _{rated} = 5 A)
Instrument current transformer	0.5 mA sec. (I _{rated} = 1 A) or 2.5 mA sec. (I _{rated} = 5 A)

Times

Operate time for current > 2-√2-threshold value	Approx. 8 ms + OOT ⁹⁵
---	----------------------------------

Tolerances

Response tolerance, current	5 % of setting value or 10 mA at I _{rated} = 1 A 5 % of setting value or 50 mA at I _{rated} = 5 A
Time delays	1 % of the setting value or 10 ms

⁹⁵ OOT (Output Operating Time) Additional delay of the output medium used, see Chap. 12.14 Relay Outputs

12.13 Instantaneous Tripping at Switch onto Fault



Setting Values

Tripping delay	0.00 s to 60.00 s	Increments of 0.01 s
----------------	-------------------	----------------------

Tolerances

Times	< 1 % of the setting value or 10 ms
-------	-------------------------------------

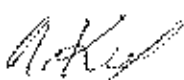

12.14 Overcurrent Protection, 1-Phase



12.14.1 Stage with Definite-Time Characteristic Curve

Setting Values

Method of measurement		Fundamental component RMS value	--
Threshold value ⁶⁶	1 A @ 50 and 100 Irated	0.030 A to 35.000 A	Increments of 0.001 A
	5 A @ 50 and 100 Irated	0.15 A to 175.00 A	Increments of 0.01 A
	1 A @ 1.6 Irated	0.003 A to 1.600 A	Increments of 0.001 A
	5 A @ 1.6 Irated	0.005 A to 8.000 A	Increments of 0.001 A
Dropout ratio (fixed)		0.95	--
Time delay		0.00 s to 60.00 s	Increments of 0.01 s

Dropout

The greater dropout differential ($= | \text{pickup value} - \text{dropout value} |$) of the following 2 criteria applies:

Dropout differential derived from the parameter Dropout ratio	
If this parameter is not available, a dropout ratio of 95 % applies for overcurrent and of 105 % for undercurrent functionality.	
Minimum absolute dropout differential	
Protection-class current transformer	15 mA sec. ($I_{rated} = 1 \text{ A}$) or 75 mA sec. ($I_{rated} = 5 \text{ A}$)
Instrument current transformer	0.5 mA sec. ($I_{rated} = 1 \text{ A}$) or 2.5 mA sec. ($I_{rated} = 5 \text{ A}$)

Times

Operate time with time delay = 0 ms	Approx. 15 ms + OOT ⁶⁷ at 50 Hz Approx. 14 ms + OOT at 60 Hz
Extension of the operate time during operation with transformer inrush-current detection	Approx. 10 ms
Dropout time	Approx. 20 ms + GOT at 50 Hz Approx. 17 ms + GOT at 60 Hz

Frequency Operating Range

$0.9 \leq f / f_{rated} \leq 1.1$	According to specified tolerances
$10 \text{ Hz} \leq f < 0.9 f_{rated}$	Slightly expanded tolerances
$1.1 f_{rated} < f \leq 80 \text{ Hz}$	
$f < 10 \text{ Hz}$	Active
$f > 80 \text{ Hz}$	

⁶⁶ If you have selected the method of measurement – RMS value, do not set the threshold value under $0.1 I_{rated,sec}$
⁶⁷ OOT (Output Operating Time) additional delay of the output medium used, see Chapter 12.1.4 Relay Outputs



A. P. ...



Tolerances

Currents, method of measurement = fundamental component	1 % of the setting value or 5 mA ($I_{rated} = 1$ A) or 25 mA ($I_{rated} = 5$ A), ($f_{rated} \pm 10$ %)
Currents, method of measurement = RMS value (33 % harmonics, in relation to fundamental component)	
Up to 30th harmonic	1 % of the setting value or 5 mA ($I_{rated} = 1$ A) or 25 mA ($I_{rated} = 5$ A), ($f_{rated} \pm 10$ %)
Up to 50th harmonic, $f_{rated} = 50$ Hz	3 % of the setting value or 20 mA ($I_{rated} = 1$ A) or 100 mA ($I_{rated} = 5$ A), ($f_{rated} \pm 10$ %)
Up to 50th harmonic, $f_{rated} = 60$ Hz	4 % of the setting value or 20 mA ($I_{rated} = 1$ A) or 100 mA ($I_{rated} = 5$ A), ($f_{rated} \pm 10$ %)
Time delays	1 % of the setting value or 10 ms

Influencing Variables for Thresholds

Transient excess pickup in method of measurement = fundamental component, for $\tau > 100$ ms (with complete unbalance)	< 5 %
---	-------

12.14.2 Stage with Inverse-Time Characteristic Curve

Setting Values

Method of measurement	Fundamental component	–
	RMS value	
Threshold value ⁶⁹	1 A @ 50 and 100 Irated	0.030 A to 35.000 A Increments of 0.001 A
	5 A @ 50 and 100 Irated	0.15 A to 175.00 A Increments of 0.01 A
	1 A @ 1.6 Irated	0.001 A to 1.600 A Increments of 0.001 A
	5 A @ 1.6 Irated	0.005 A to 8.000 A Increments of 0.001 A
Dropout	Disk emulation Instantaneous	–
Time multiplier	0.05 to 15.00	Increments of 0.01

Dropout

The greater dropout differential (= | pickup value – dropout value |) of the following 2 criteria applies:

Dropout	95 % of 1.3 · threshold value
Minimum absolute dropout differential	
Protection-class current transformer	15 mA sec. ($I_{rated} = 1$ A) or 75 mA sec. ($I_{rated} = 5$ A)
Instrument current transformer	0.5 mA sec. ($I_{rated} = 1$ A) or 2.5 mA sec. ($I_{rated} = 5$ A)

Reset of the Integration Timer

Instantaneous	With dropout
---------------	--------------

⁶⁹If you have selected the method of measurement = RMS value, do not set the threshold value under 0.1 $I_{rated,sec}$

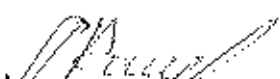

Disk emulation	Approx. $< 0.90 \cdot$ threshold value
----------------	--

Operate Curves and Dropout-Time Characteristic Curves According to IEC

Extension of the operate time during operation with transformer inrush-current detection	Approx. 10 ms
--	---------------

The tripping characteristic curves and dropout characteristic curves according to IEC can be found in the Technical Data chapter under Inverse Time-Overcurrent Protection.

Operate Curves and Dropout-Time Characteristic Curves According to ANSI/IEEE

The tripping characteristic curves and dropout characteristic curves according to ANSI/IEEE can be found in the Technical Data chapter under Inverse Time-Overcurrent Protection.

Frequency Operating Range

$0.9 \leq f/f_{rated} \leq 1.1$	According to specified tolerances
$10 \text{ Hz} \leq f < 0.9 f_{rated}$	Slightly expanded tolerances
$1.1 f_{rated} < f \leq 80 \text{ Hz}$	
$f < 10 \text{ Hz}$ $f > 80 \text{ Hz}$	Active

Tolerances

Currents, method of measurement = fundamental component	$\pm 1\%$ of the setting value or 5 mA ($I_{rated} = 1 \text{ A}$) or 25 mA ($I_{rated} = 5 \text{ A}$), ($f_{rated} + 10\%$)
Currents, method of measurement = RMS value (33 % harmonics, in relation to fundamental component)	
Up to 30th harmonic	$\pm 1\%$ of the setting value or 5 mA ($I_{rated} = 1 \text{ A}$) or 25 mA ($I_{rated} = 5 \text{ A}$), ($f_{rated} \pm 10\%$)
Up to 50th harmonic, $f_{rated} = 50 \text{ Hz}$	$\pm 3\%$ of the setting value or 20 mA ($I_{rated} = 1 \text{ A}$) or 100 mA ($I_{rated} = 5 \text{ A}$), ($f_{rated} + 10\%$)
Up to 50th harmonic, $f_{rated} = 60 \text{ Hz}$	$\pm 4\%$ of the setting value or 20 mA ($I_{rated} = 1 \text{ A}$) or 100 mA ($I_{rated} = 5 \text{ A}$), ($f_{rated} \pm 10\%$)
Operate time for $2 \leq I/I$ threshold value < 20	5 % of the reference (calculated) value $\pm 2\%$ current tolerance or 30 ms
Dropout time for I/I threshold value ≤ 0.90	5 % of the reference (calculated) value $\pm 2\%$ current tolerance or 30 ms

Influencing Variables for Thresholds

Transient excess pickup in method of measurement = fundamental component, for $\tau > 100 \text{ ms}$ (with complete unbalance)	$< 5\%$
---	---------

12.14.3 Stage with User-Defined Characteristic Curve

Setting Values

Method of measurement	Fundamental component RMS value
-----------------------	------------------------------------



Threshold value	1 A @ 50 and 100 I _{rated}	0.030 A to 35.000 A	Increments of 0.001 A
	5 A @ 50 and 100 I _{rated}	0.15 A to 175.00 A	Increments of 0.01 A
	1 A @ 1.6 I _{rated}	0.003 A to 1.600 A	Increments of 0.001 A
	5 A @ 1.6 I _{rated}	0.005 A to 8.000 A	increments of 0.001 A
Dropout		Disk emulation Instantaneous	-
Time multiplier		0.05 to 15.00	Increments of 0.01
Number of value pairs for the operate curve		2 to 30	Increments of 1
X values of the operate curve		1.00 p.u. to 66.67 p. u.	Increments of 0.01 p.u.
Y values of the operate curve		0.00 s to 999.00 s	Increments of 0.01 s
Number of value pairs for the dropout characteristic curve		2 to 30	Increments of 1
X values of the dropout characteristic curve		0.05 p.u. to 0.95 p. u.	Increments of 0.01 p.u.
Y values of the dropout characteristic curve		0.00 s to 999.00 s	Increments of 0.01 s

Dropout

The greater dropout differential (= | pickup value - dropout value |) of the following 2 criteria applies:

Dropout	95 % of 1.1 · threshold value
Minimum absolute dropout differential	
Protection class current transformer	15 mA sec. (I _{rated} = 1 A) or 75 mA sec. (I _{rated} = 5 A)
Instrument current transformer	0.5 mA sec. (I _{rated} = 1 A) or 2.5 mA sec. (I _{rated} = 5 A)

Reset of the Integration Timer

Instantaneous	With dropout
Disk emulation	Approx. < 0.90 · threshold value

Frequency Operating Range

$0.9 \leq f/f_{rated} < 1.1$	According to specified tolerances
$10 \text{ Hz} \leq f < 0.9 f_{rated}$	Slightly expanded tolerances
$1.1 f_{rated} < f \leq 80 \text{ Hz}$	
$f < 10 \text{ Hz}$	Active with less sensitivity
$f > 80 \text{ Hz}$	

Tolerances

Currents, method of measurement = fundamental component	1 % of the setting value or 5 mA (I _{rated} = 1 A) or 25 mA (I _{rated} = 5 A), (I _{rated} ± 10 %)
Currents, method of measurement = RMS value (33 % harmonics, in relation to fundamental component)	
Up to 30th harmonic	1 % of the setting value or 5 mA (I _{rated} = 1 A) or 25 mA (I _{rated} = 5 A), (f _{rated} ± 10 %)
Up to 50th harmonic, f _{rated} = 50 Hz	3 % of the setting value or 20 mA (I _{rated} = 1 A) or 100 mA (I _{rated} = 5 A), (f _{rated} ± 10 %)

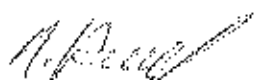
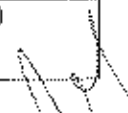



Up to 50th harmonic, $f_{rated} \approx 60$ Hz	4 % of the setting value or 20 mA ($I_{rated} = 1$ A) or 100 mA ($I_{rated} = 5$ A), ($f_{rated} \pm 10$ %)
Operate time for $2 \leq I/I$ threshold value ≤ 20	5 % of the reference (calculated) value +2 % current tolerance or 30 ms
Dropout time for I/I threshold value ≤ 0.90	5 % of the reference (calculated) value +2 % current tolerance or 30 ms

Influencing Variables for Thresholds

Transient excess pickup in method of measurement = fundamental component, for $\tau > 100$ ms (with complete unbalance)	< 5 %
---	-------

Operate Curves and Dropout-Time Characteristic Curves According to IEC

Extension of the operate time during operation with transformer inrush-current detection	Approx. 10 ms
--	---------------

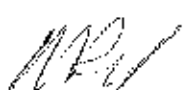



12.15 Overcurrent Protection, 1-Phase (Fast Stage)

Setting Values

Threshold value	1 A @ 50 and 100 Irated	0.030 A to 35.000 A	Increments of 0.001 A
	5 A @ 50 and 100 Irated	0.15 A to 175.00 A	Increments of 0.01 A
	1 A @ 1.6 Irated	0.001 A to 1.600 A	Increments of 0.001 A
	5 A @ 1.6 Irated	0.005 A to 8.000 A	increments of 0.001 A
Dropout ratio (fixed)		0.90 to 0.99	Increments of 0.01
Time delay		0.00 s to 60.00 s	increments of 0.01 s

Dropout

The greater dropout differential (= | pickup value - dropout value |) of the following 2 criteria applies:

Dropout differential derived from the parameter Dropout ratio	
If this parameter is not available, a dropout ratio of 95 % applies for overcurrent and of 105 % for undercurrent functionality.	
Minimum absolute dropout differential	
Protection-class current transformer	35 mA sec. ($I_{rated} = 1 \text{ A}$) or 75 mA sec. ($I_{rated} = 5 \text{ A}$)
Instrument current transformer	0.5 mA sec. ($I_{rated} = 1 \text{ A}$) or 2.5 mA sec. ($I_{rated} = 5 \text{ A}$)

Times

Operate time with time delay = 0 ms	Approx. 8 ms + OOT ⁶⁹
Dropout time	Approx. 25 ms + OOT

Frequency Operating Range

$0.9 \leq f/I_{rated} \leq 1.1$	According to specified tolerances
$10 \text{ Hz} \leq f < 0.9 f_{rated}$	Slightly expanded tolerances
$1.1 f_{rated} < f \leq 80 \text{ Hz}$	
$f < 10 \text{ Hz}$	Active
$f > 80 \text{ Hz}$	

Tolerances

Pickup tolerance, current	5 % of the setting value or 10 mA ($I_{rated} = 1 \text{ A}$) or 50 mA ($I_{rated} = 5 \text{ A}$)
Time delays	1 % of the setting value or 10 ms

⁶⁹ OOT (Output Operating Time) additional time delay of the output medium used, for example, 5 ms with fast relay

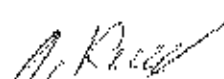



12.16 Non-Directional Intermittent Ground-Fault Protection

Setting Values

Threshold value $I_{th} > I_{interm}$.	For current transformer type protection and $I_{rated} = 1 \text{ A}$	0.030 A to 35.000 A	Increments of 0.001 A	
	For current transformer type protection and $I_{rated} = 5 \text{ A}$	0.15 A to 175.00 A	Increments of 0.01 A	
	For I_N transformer type sensitive and $I_{N-rated} = 1 \text{ A}$	For $I_{ph-rated} = 1 \text{ A}$	0.001 A to 35.000 A	Increments of 0.001 A
		For $I_{ph-rated} = 5 \text{ A}$	0.001 A to 175.000 A	Increments of 0.001 A
	For I_N transformer type sensitive and $I_{N-rated} = 5 \text{ A}$	For $I_{ph-rated} = 1 \text{ A}$	0.005 A to 35.000 A	Increments of 0.001 A
		For $I_{ph-rated} = 5 \text{ A}$	0.005 A to 175.000 A	Increments of 0.001 A
Number of pickups until intermittent ground fault		2 to 10	Increments of 1	
Pickup extension time		0.00 s to 10.00 s	Increments of 0.01 s	
Sum of extended pickup times		0.00 s to 100.00 s	Increments of 0.01 s	
Reset time		1.00 s to 600.00 s	Increments of 0.01 s	

Dropout

The greater dropout differential (= { pickup value - dropout value }) of the following 2 criteria applies:

Dropout differential derived from the parameter Dropout ratio	
If this parameter is not available, a dropout ratio of 95 % applies for overcurrent and of 305 % for undercurrent functionality.	
Minimum absolute dropout differential	
Protection-class current transformer	15 mA sec. ($I_{rated} = 1 \text{ A}$) or 75 mA sec. ($I_{rated} = 5 \text{ A}$)
Instrument current transformer	0.5 mA sec. ($I_{rated} = 1 \text{ A}$) or 2.5 mA sec. ($I_{rated} = 5 \text{ A}$)

Times

Operate time with time delay – 0 ms	Approx. 25 ms + OOT ¹⁾ at 50 Hz Approx. 23 ms + OOT at 60 Hz
Dropout time	Approx. 25 ms + OOT at 50 Hz Approx. 22 ms + OOT at 60 Hz

Frequency Operating Range

$0.9 \leq f/f_{rated} \leq 1.1$	According to specified tolerances
$10 \text{ Hz} \leq f < 0.9 f_{rated}$ $1.1 f_{rated} < f \leq 80 \text{ Hz}$	Slightly expanded tolerances
$f < 10 \text{ Hz}$ $f > 80 \text{ Hz}$	Active with less sensitivity

¹⁾OOT (Output Operating Time) additional delay of the output medium used, for example 5 ms with fast relays

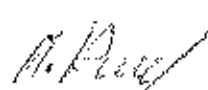



Tolerances

Currents	-310 via protection-class current transformers: ± % of setting value or 5 mA ($I_{rated} = 1\text{ A}$) or 25 mA ($I_{rated} = 5\text{ A}$)
	-310 via sensitive current transformer: 1 % of setting value or 0.1 mA ($I_{rated} = 1.6\text{ A}$) or 0.5 mA ($I_{rated} = 8\text{ A}$)
Times	1 % of the setting value or ± 10 ms

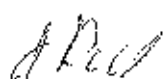



12.17 Directional Intermittent Ground-Fault Protection

Setting Values

Threshold value $3I_{D>}$	For current transformer type protection and $I_{rated} = 1\text{ A}$	0.030 A to 35.000 A	Increments of 0.001 A	
	For current transformer type protection and $I_{rated} = 5\text{ A}$	0.15 A to 175.00 A	Increments of 0.01 A	
	For I_N transformer type sensitive and $I_{N-rated} = 1\text{ A}$	For $I_{ph-rated} = 1\text{ A}$	0.001 A to 35.000 A	increments of 0.001 A
		For $I_{ph-rated} = 5\text{ A}$	0.001 A to 175.000 A	Increments of 0.001 A
For I_N transformer type sensitive and $I_{N-rated} = 5\text{ A}$	For $I_{ph-rated} = 1\text{ A}$	0.005 A to 35.000 A	Increments of 0.001 A	
	For $I_{ph-rated} = 5\text{ A}$	0.005 A to 175.000 A	Increments of 0.001 A	
Number of pulses until intermittent ground fault		2 to 10	Increments of 1	
Pickup extension time		0.00 s to 10.00 s	increments of 0.01 s	
Sum of extended pickup times		0.00 s to 100.00 s	Increments of 0.01 s	
Reset time		1.00 s to 600.00 s	Increments of 0.01 s	
Number of pulses for operate		2 to 100	Increments of 1	

Dropout

The greater dropout differential ($- | \text{pickup value} - \text{dropout value} |$) of the following 2 criteria applies:

Dropout differential derived from the parameter Dropout ratio	
If this parameter is not available, a dropout ratio of 95 % applies for overcurrent and of 105 % for undercurrent functionality.	
Minimum absolute dropout differential	
Protection-class current transformer	15 mA sec. ($I_{rated} = 1\text{ A}$) or 75 mA sec. ($I_{rated} = 5\text{ A}$)
Instrument current transformer	0.5 mA sec. ($I_{rated} = 1\text{ A}$) or 2.5 mA sec. ($I_{rated} = 5\text{ A}$)

Times

Pickup time	Approx. 30 ms + OOT ⁷¹ at 50 Hz Approx. 23 ms + OOT at 60 Hz
Dropout time	Approx. 25 ms + OOT at 50 Hz Approx. 22 ms + OOT at 60 Hz

Frequency Operating Range

$0.9 \leq f/f_{rated} \leq 1.1$	According to specified tolerances
$10\text{ Hz} \leq f < 0.9 f_{rated}$	Slightly expanded tolerances
$1.1 f_{rated} < f \leq 80\text{ Hz}$	
$f < 10\text{ Hz}$ $f > 80\text{ Hz}$	Active with less sensitivity

⁷¹ OOT (Output Operating Time) additional delay of the output medium used, for example 5 ms with fast relays

Al Reza



Tolerances

Currents	310 via protection-class current transformers: 1 % of the setting value or 5 mA ($I_{rated} = 1\text{ A}$) or 25 mA ($I_{rated} = 5\text{ A}$)
	310 via sensitive current transformer: 1 % of the setting value or 0.1 mA ($I_{rated} = 1.6\text{ A}$) or 0.5 mA ($I_{rated} = 8\text{ A}$)
Times	1 % of the setting value or $\pm 10\text{ ms}$

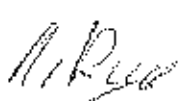

12.18 Sensitive Ground-Fault Detection



12.18.1 General

Setting Values

Decay time V0		0.06 s to 0.20 s	Increments of 0.01 s
Dropout delay		0.00 s to 60.00 s	Increments of 0.01 s
Core balance current transformer current I1	Protection-class current transformers	For $I_{ph-rated} = 1$ A	0.030 A to 35.000 A
		For $I_{ph-rated} = 5$ A	0.15 A to 175.00 A
Core balance current transformer current I2	For I_N transformer type sensitive and $I_{N-rated} = 1$ A	For $I_{ph-rated} = 3$ A	0.001 A to 35.000 A
		For $I_{ph-rated} = 5$ A	0.001 A to 175.000 A
	For I_N transformer type sensitive and $I_{N-rated} = 5$ A	For $I_{ph-rated} = 1$ A	0.005 A to 35.000 A
		For $I_{ph-rated} = 5$ A	0.005 A to 175.000 A
Core balance current transformer angle correction F1		0.0° to 5.0°	Increments of 0.1°
Core balance current transformer angle correction F2			

Times

Pickup times	Approx. 25 ms + OOT ⁷² at 50 Hz Approx. 23 ms + OOT at 60 Hz
Dropout times	Approx. 25 ms + OOT at 50 Hz Approx. 22 ms + OOT at 60 Hz

Frequency Operating Range

$0.9 \leq f/f_{rated} \leq 1.1$	According to specified tolerances
$10 \text{ Hz} \leq f < 0.9 f_{rated}$ $1.1 f_{rated} < f \leq 80 \text{ Hz}$	Slightly expanded tolerances ⁷³
$f < 10 \text{ Hz}$ $f > 80 \text{ Hz}$	Active with less sensitivity ⁷⁴

Tolerances

Currents	310 via sensitive current transformer: 1 % of the setting value or 0.1 mA ($I_{rated} = 1.6$ A) or 0.5 mA ($I_{rated} = 8$ A, $f_{rated} \pm 10$ %)
	310 via protection-class current transformers: 1 % of the setting value or 5 mA ($I_{rated} = 1$ A) or 25 mA ($I_{rated} = 5$ A, $f_{rated} \pm 10$ %)
Voltagess	1 % of the setting value or 0.05 V
Times	1 % of the setting value or ± 10 ms

⁷² OOT (Output Operating Time) additional delay of the output medium used, for example 5 ms with fast relays

⁷³ Transient ground fault stage is inactive

⁷⁴ Transient ground-fault stage is inactive

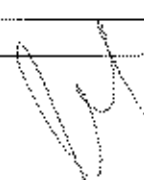

Direction-calculation angle error ⁷⁵	$\leq 1^\circ$ at $3I_0 > 5 \text{ mA}$, $V_0 = 0.6 \text{ V}$ $\leq 2^\circ$ at $3I_0 \leq 5 \text{ mA}$, $V_0 = 0.6 \text{ V}$
---	---

12.18.2 Directional 3I0 Stage with Cos φ or Sin φ Measurement

Setting Values

Direction method of measurement			cos φ	sin φ	-
Threshold value $3I_0 >$ Minimum directional $3I_0 >$ for direction determination	Protection-class current transformers	For $I_{ph-rated} = 1 \text{ A}$	0.030 A to 35.000 A		Increments of 0.001 A
		For $I_{ph-rated} = 5 \text{ A}$	0.15 A to 175.00 A		Increments of 0.01 A
	For I_{tr} transformer type sensitive and $I_{tr-rated} = 1 \text{ A}$	For $I_{ph-rated} = 1 \text{ A}$	0.001 A to 35.000 A		Increments of 0.001 A
		For $I_{ph-rated} = 5 \text{ A}$	0.001 A to 175.000 A		Increments of 0.001 A
	For I_{tr} transformer type sensitive and $I_{tr-rated} = 5 \text{ A}$	For $I_{ph-rated} = 1 \text{ A}$	0.005 A to 35.000 A		Increments of 0.001 A
		For $I_{ph-rated} = 5 \text{ A}$	0.005 A to 175.000 A		Increments of 0.001 A
Threshold value $V_0 >$			0.300 V to 200.000 V		Increments of 0.001 V
Time delay of the direction determination			0.00 s to 60.00 s		Increments of 0.01 s
$\alpha 1$ constraint of the direction range			1° to 35°		Increments of 1°
$\alpha 2$ constraint of the direction range					
Angle correction φ			45° to 45°		Increments of 1°
Tripping delay			0.00 s to 60.00 s		Increments of 0.01 s

Dropout

The greater dropout differential ($= | \text{pickup value} - \text{dropout value} |$) of the following 2 criteria applies:

Dropout differential derived from the parameter Dropout ratio	
If this parameter is not available, a dropout ratio of 95 % applies for overcurrent/overvoltage and of 105 % for undercurrent/undervoltage functionality.	
Minimum absolute dropout differential	
Protection-class current transformer	15 mA sec. ($I_{rated} = 1 \text{ A}$) or 75 mA sec. ($I_{rated} = 5 \text{ A}$)
Instrument current transformer	0.5 mA sec. ($I_{rated} = 1 \text{ A}$) or 2.5 mA sec. ($I_{rated} = 5 \text{ A}$)
Voltage transformer	150 mV sec.

Times

Operate time with time delay = 0 ms	Approx. 32 ms + OOT ⁷⁶ at 50 Hz Approx. 29 ms + OOT at 60 Hz
Extension of the operate time during operation with transformer inrush-current detection	Approx. 10 ms

⁷⁵ Not applicable to 12.18.4 Directional 3I0 Stage with φV0 3I0 Measurement

⁷⁶ OOT (Output Operating Time) additional delay of the output medium used, see Chapter 12.1.4 Relay Outputs

Handwritten signature

Handwritten signature



Dropout time	Approx. 32 ms + OOT at 50 Hz Approx. 27 ms + OOT at 60 Hz
--------------	--

12.18.3 Directional Transient Ground-Fault Stage

Setting Values

Threshold value $I_{0>}$	Protection-class current transformers	For $I_{ph-rated} = 1 \text{ A}$	0.030 A to 35.000 A	Increments of 0.001 A
		For $I_{ph-rated} = 5 \text{ A}$	0.15 A to 175.00 A	Increments of 0.01 A
	For I_N transformer type sensitive and $I_{N-rated} = 1 \text{ A}$	For $I_{ph-rated} = 1 \text{ A}$	0.001 A to 1.600 A	Increments of 0.001 A
		For $I_{ph-rated} = 5 \text{ A}$	0.005 A to 8.000 A	Increments of 0.001 A
	For I_N transformer type sensitive and $I_{N-rated} = 5 \text{ A}$	For $I_{ph-rated} = 1 \text{ A}$	0.001 A to 1.600 A	Increments of 0.001 A
		For $I_{ph-rated} = 5 \text{ A}$	0.005 A to 8.000 A	Increments of 0.001 A
Threshold value $V_{0>}$			0.300 V to 200.000 V	Increments of 0.001 V
Maximum operational V_0			0.300 V to 340.000 V	Increments of 0.001 V
Tripping delay			0.00 s to 60.00 s	Increments of 0.01 s

Dropout

The greater dropout differential (= | pickup value - dropout value |) of the following 2 criteria applies:

Dropout differential derived from the parameter Dropout ratio	
If this parameter is not available, a dropout ratio of 95 % applies for overcurrent/overvoltage and of 105 % for undercurrent/undervoltage functionality.	
Minimum absolute dropout differential	
Protection-class current transformer	15 mA sec. ($I_{rated} = 1 \text{ A}$) or 75 mA sec. ($I_{rated} = 5 \text{ A}$)
Instrument current transformer	0.5 mA sec. ($I_{rated} = 1 \text{ A}$) or 2.5 mA sec. ($I_{rated} = 5 \text{ A}$)
Voltage transformer	150 mV sec.

Times

Operate time with time delay = 0 ms	Approx. 115 ms + OOT** at 50 Hz Approx. 112 ms + OOT at 60 Hz
Dropout time	Approx. 20 ms + OOT at 50 Hz Approx. 15 ms + OOT at 60 Hz

** OOT (Output Operating Time) additional delay of the output medium used, see chapter 12.14 Relay Outputs

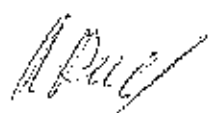



12.18.4 Directional 3I0 Stage with $\varphi(V0,3I0)$ Measurement

Setting Values

Threshold value 3I0>	Protection-class current transformers	For $I_{ph-rated} = 1\text{ A}$	0.030 A to 35.000 A	Increments of 0.001 A
		For $I_{ph-rated} = 5\text{ A}$	0.15 A to 175.00 A	increments of 0.01 A
	For I_N transformer type sensitive and $I_{N-rated} = 1\text{ A}$	For $I_{ph-rated} = 1\text{ A}$	0.001 A to 35.000 A	Increments of 0.001 A
		For $I_{ph-rated} = 5\text{ A}$	0.001 A to 175.000 A	Increments of 0.001 A
For I_N transformer type sensitive and $I_{N-rated} = 5\text{ A}$	For $I_{ph-rated} = 1\text{ A}$	0.005 A to 35.000 A	Increments of 0.001 A	
	For $I_{ph-rated} = 5\text{ A}$	0.005 A to 175.000 A	Increments of 0.001 A	
Min. V0> for direction determination			0.300 V to 200.000 V	Increments of 0.001 V
Time delay of the direction determination			0.00 s to 60.00 s	Increments of 0.01 s
Rotation angle of the reference voltage			-180° to 180°	Increments of 1°
Forward range +/-			0° to 180°	Increments of 2°
Tripping delay			0.00 s to 60.00 s	Increments of 0.01 s

Dropout

The greater dropout differential (= | pickup value - dropout value |) of the following 2 criteria applies:

Dropout differential derived from the parameter Dropout ratio	
If this parameter is not available, a dropout ratio of 95 % applies for overcurrent/overvoltage and of 105 % for undercurrent/undervoltage functionality.	
Minimum absolute dropout differential	
Protection-class current transformer	15 mA sec. ($I_{rated} = 1\text{ A}$) or 75 mA sec. ($I_{rated} = 5\text{ A}$)
Instrument current transformer	0.5 mA sec. ($I_{rated} = 1\text{ A}$) or 2.5 mA sec. ($I_{rated} = 5\text{ A}$)
Voltage transformer	150 mV sec.

Times

Operate time with time delay = 0 ms	Approx. 23 ms + OOT [#] at 50 Hz Approx. 21 ms + OOT at 60 Hz
Extension of operate time during operation with transformer inrush-current detection	Approx. 10 ms
Dropout time	Approx. 21 ms + OOT at 50 Hz Approx. 20 ms + OOT at 60 Hz

Tolerances

Direction-calculation angle error	$\leq 1^\circ$ at $3I0 \geq 10\text{ mA}$, $V0 = 0.6\text{ V}$ $\leq 2^\circ$ at $2\text{ mA} < 3I0 < 10\text{ mA}$, $V0 = 0.6\text{ V}$ $\leq 3^\circ$ at $3I0 \leq 2\text{ mA}$, $V0 = 0.6\text{ V}$
-----------------------------------	---



[#]OOT (Output Operating Time) additional delay of the output medium used, see chapter 12.14 Relay Outputs

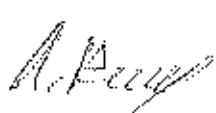



12.18.5 Directional Y0 Stage with G0 or B0 Measurement (Admittance)

Setting Values

Direction: method of measurement			B0	G0	...
Release Threshold value 3I0>	Protection-class current transformers	For $I_{ph-rated} = 1\text{ A}$	0.030 A to 35.000 A	increments of 0.001 A	
		For $I_{ph-rated} = 5\text{ A}$	0.15 A to 175.00 A	increments of 0.001 A	
	For I_N transformer type sensitive and $I_{N-rated} = 1\text{ A}$	For $I_{ph-rated} = 1\text{ A}$	0.001 A to 35.000 A	increments of 0.001 A	
		For $I_{ph-rated} = 5\text{ A}$	0.001 A to 175.000 A	increments of 0.001 A	
	For I_N transformer type sensitive and $I_{N-rated} = 5\text{ A}$	For $I_{ph-rated} = 1\text{ A}$	0.005 A to 35.000 A	increments of 0.001 A	
		For $I_{ph-rated} = 5\text{ A}$	0.005 A to 175.000 A	increments of 0.001 A	
Threshold value V0>			0.300 V to 200.000 V	increments of 0.001 V	
Threshold value Y0>			0.10 mS to 100.00 mS	increments of 0.01 mS	
Time delay of direction determination			0.00 s to 60.00 s	increments of 0.01 s	
a1 constraint of direction range			1° to 15°	increments of 1°	
a2 constraint of direction range					
Angle correction φ			45° to 45°	increments of 1°	
Tripping delay			0.00 s to 60.00 s	increments of 0.01 s	

Dropout

The greater dropout differential (= | pickup value - dropout value |) of the following 2 criteria applies:

Dropout differential derived from the parameter Dropout ratio	
If this parameter is not available, a dropout ratio of 95 % applies for overcurrent/overvoltage and of 10% % for undercurrent/undervoltage functionality.	
Minimum absolute dropout differential	
Protection-class current transformer	15 mA sec. ($I_{rated} = 1\text{ A}$) or 75 mA sec. ($I_{rated} = 5\text{ A}$)
Instrument current transformer	0.5 mA sec. ($I_{rated} = 1\text{ A}$) or 2.5 mA sec. ($I_{rated} = 5\text{ A}$)
Voltage transformer	150 mV sec.

Times

Operate time with time delay = 0 ms	Approx. 32 ms + OOT ²⁹ at 50 Hz Approx. 29 ms + OOT at 60 Hz
Extension of operate time during operation with transformer inrush-current detection	Approx. 10 ms
Dropout time	Approx. 32 ms + OOT at 50 Hz Approx. 27 ms + OOT at 60 Hz

²⁹OOT (Output Operating Time) additional delay of the output medium used, see chapter 12.14 Relay Outputs





Tolerances

Admittance	1 % of the setting value or 0.05 mS ($I_{rated} = 1.6 \text{ A}$) or 0.25 mS ($I_{rated} = 8 \text{ A}$), ($f_{ratec} = \pm 10 \%$)
------------	---

12.18.6 Non-Directional V0 Stage with Zero-Sequence Voltage/Residual Voltage

Setting Values

Threshold value ⁹⁰	0.300 V to 200.000 V	Increments of 0.001 V
Time delay	0.00 s to 60.00 s	Increments of 0.01 s
Pickup delay	0.00 s to 60.00 s	Increments of 0.01 s
Dropout ratio	0.90 to 0.99	Increments of 0.01
$V <$ faulty ph-gnd. vltg.	0.300 V to 200.000 V	Increments of 0.001 V
$V >$ healthy ph-gnd. vltg.	0.300 V to 200.000 V	Increments of 0.001 V

Dropout

The greater dropout differential ($- | \text{pickup value} - \text{dropout value} |$) of the following 2 criteria applies:

Dropout differential derived from the parameter Dropout ratio	
If this parameter is not available, a dropout ratio of 95 % applies for the overvoltage and of 105 % for the undervoltage functionality.	
Minimum absolute dropout differential	±50 mV sec.

Times

Operate time with time delay = 0 ms	
Standard filter, true RMS	Approx. 25 ms + OOT ⁹¹ at 50 Hz Approx. 22 ms + OOT at 60 Hz
2 cycle filters	Approx. 45 ms + OOT ⁹¹ at 50 Hz Approx. 39 ms + OOT at 60 Hz
Dropout time	
Standard filter, true RMS	Approx. 20 ms + OOT at 50 Hz Approx. 16.6 ms + OOT at 60 Hz
2 cycle filters	Approx. 31.06 ms + OOT at 50 Hz Approx. 27.06 ms + OOT at 60 Hz

Frequency Operating Range

$0.9 \leq f/f_{rated} \leq 1.1$	According to specified tolerances
$10 \text{ Hz} \leq f < 0.9 f_{rated}$	Slightly expanded tolerances
$1.1 f_{rated} < f \leq 80 \text{ Hz}$	
$f < 10 \text{ Hz}$	Active
$f > 80 \text{ Hz}$	

Tolerances

Voltages	0.5 % of the setting value or 0.05 V
Time delays	1 % of the setting value or 10 ms

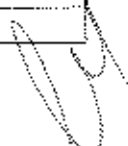

⁹⁰if you have selected the method of measurement – RMS value, do not set the threshold value under 10 V.

⁹¹OOT (Output Operating Time) additional delay of the output medium used, see Chapter 12.14 Relay Outputs

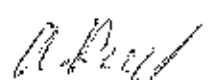

12.18.7 Non-Directional 3I0 Stage

Setting Values

Method of Measurement			Fundamental component RMS value	
Threshold value 3I0>	Protection-class current transformers	For $I_{ph-rated} = 1\text{ A}$	0.030 A to 35.000 A	Increments of 0.001 A
		For $I_{ph-rated} = 5\text{ A}$	0.15 A to 175.00 A	Increments of 0.01 A
	For transformer type I-sensitive and $I_{N-rated} = 1\text{ A}$	For $I_{ph-rated} = 1\text{ A}$	0.001 A to 35.000 A	Increments of 0.001 A
		For $I_{ph-rated} = 5\text{ A}$	0.001 A to 175.000 A	Increments of 0.001 A
	For transformer type I-sensitive and $I_{N-rated} = 5\text{ A}$	For $I_{ph-rated} = 1\text{ A}$	0.005 A to 35.000 A	Increments of 0.001 A
		For $I_{ph-rated} = 5\text{ A}$	0.005 A to 175.000 A	Increments of 0.001 A
Pickup delay			0.00 s to 60.00 s	Increments of 0.01 s
Tripping delay			0.00 s to 60.00 s	Increments of 0.01 s

Dropout

The greater dropout differential ($\sim | \text{pickup value} - \text{dropout value} |$) of the following 2 criteria applies:

Dropout differential derived from the parameter Dropout ratio	
If this parameter is not available, a dropout ratio of 95 % applies for overcurrent and of 105 % for undercurrent functionality.	
Minimum absolute dropout differential	
Protection class current transformer	15 mA sec. ($I_{rated} = 1\text{ A}$) or 75 mA sec. ($I_{rated} = 5\text{ A}$)
Instrument current transformer	0.5 mA sec. ($I_{rated} = 1\text{ A}$) or 2.5 mA sec. ($I_{rated} = 5\text{ A}$)

Times

Operate time with time delay = 0 ms	Approx. 25 ms + 0.07 ⁰² at 50 Hz Approx. 23 ms + 0.07 at 60 Hz
Extension of the operate time during operation with transformer inrush-current detection	Approx. 10 ms
Dropout time	Approx. 25 ms + 0.07 at 50 Hz Approx. 22 ms + 0.07 at 60 Hz

12.18.8 Non-Directional Y0 Stage

Setting Values

V0> threshold value	0.300 V to 200.000 V	Increments of 0.001 V
Threshold Y0>	0.10 ms to 100.00 ms	Increments of 0.01 ms

⁰² 0.07 (Output Operating Time) additional delay of the output medium used, see chapter 12.1.4 Relay Outputs

Technical Data

12.18 Sensitive Ground-Fault Detection

Pickup delay	0.00 s to 60.00 s	Increments of 0.01 s
Operate delay	0.00 s to 60.00 s	Increments of 0.01 s

Dropout

The greater dropout differential (= | pickup value - dropout value |) of the following 2 criteria applies:

Dropout differential derived from the parameter Dropout ratio	
If this parameter is not available, a dropout ratio of 95 % applies for the overvoltage and of 105 % for the undervoltage functionality.	
Minimum absolute dropout differential	150 mV sec.

Times

Operate time with time delay = 0 ms	Approx. 32 ms + OOT [#] at 50 Hz Approx. 29 ms + OOT at 60 Hz
Extension of operate time during operation with transformer inrush-current detection	Approx. 10 ms
Dropout time	Approx. 32 ms + OOT at 50 Hz Approx. 27 ms + OOT at 60 Hz

Tolerances

Admittance	1 % of the setting value or 0.05 mS ($I_{\text{rated}} = 1.6 \text{ A}$) or 0.25 mS ($I_{\text{rated}} = 8 \text{ A}$), ($f_{\text{rated}} = \pm 10 \%$)
------------	--

[#] OOT (Output Operating Time) additional relay of the output medium used, see chapter 12.14 Relay Outputs



12.19 Undercurrent Protection

Setting Values

Method of measurement	Fundamental component RMS value	-
Threshold value I_c	1 A @ 50 and 100 Irated	0.030 A to 35.000 A Increments of 0.001 A
	5 A @ 50 and 100 Irated	0.15 A to 175.00 A Increments of 0.01 A
	1 A @ 1.6 Irated	0.001 A to 1.600 A Increments of 0.001 A
	5 A @ 1.6 Irated	0.005 A to 8.000 A Increments of 0.001 A
Time delay	0.00 s to 60.00 s	Increments of 0.01 s

Dropout

The greater dropout differential ($= I_{pickup\ value} - dropout\ value$) of the following 2 criteria applies:

Dropout differential derived from the parameter Dropout ratio If this parameter is not available, a dropout ratio of 95 % applies for overcurrent and of 105 % for undercurrent functionality.	
Minimum absolute dropout differential	
Protection-class current transformer	15 mA sec. ($I_{rated} = 1\ A$) or 75 mA sec. ($I_{rated} = 5\ A$)
Instrument current transformer	0.5 mA sec. ($I_{rated} = 1\ A$) or 2.5 mA sec. ($I_{rated} = 5\ A$)

Times

Operate time	Approx. 25 ms + OOT ²⁴ at 50 Hz Approx. 22 ms + OOT at 60 Hz
Dropout time	Approx. 25 ms + OOT at 50 Hz Approx. 22 ms + OOT at 60 Hz

Frequency Operating Range

$0.9 \leq f/f_{rated} \leq 1.1$	According to specified tolerances
$10\ Hz \leq f < 0.9 f_{rated}$ $1.1 f_{rated} < f \leq 80\ Hz$	Slightly expanded tolerances
$f < 10\ Hz$ $f > 80\ Hz$	Inactive

Tolerances

Currents, method of measurement = fundamental component	1 % of setting value or 5 mA ($I_{rated} = 1\ A$) or 25 mA ($I_{rated} = 5\ A$), ($f_{rated} \pm 10\%$)
Currents, method of measurement = RMS value (33 % portion harmonic, referring to fundamental component)	
Up to 30th harmonic	1 % of setting value or 5 mA ($I_{rated} = 1\ A$) or 25 mA ($I_{rated} = 5\ A$), ($f_{rated} \pm 10\%$)

²⁴ OOT (Output Operating Time) additional delay of the output medium used, for example, 5 ms with fast relays, see Chapter Relay Outputs

Accepted

Up to 50th harmonic, $f_{rated} = 50$ Hz	3 % of setting value or 20 mA ($I_{rated} = 1$ A) or 100 mA ($I_{rated} = 5$ A), ($f_{rated} \pm 10$ %)
Up to 50th harmonic, $f_{rated} = 60$ Hz	4 % of setting value or 20 mA ($I_{rated} = 1$ A) or 100 mA ($I_{rated} = 5$ A), ($f_{rated} \pm 10$ %)
Time delays	1 % of the setting value or 10 ms



12.20 Negative-Sequence Protection

12.20.1 Stage with Definite-Time Characteristic Curve

Setting Values

Reference value for I_2 (I_{2ref})	Rated object current $I_{rated, obj}$	Positive-sequence current I_1	
Pickup value	5.0 % to 999.9 % I_{2ref}		Increments of 0.1
Dropout ratio	0.40 to 0.99		Increments of 0.01
Time delay	0.00 s to 60.00 s		Increments of 0.01 s
Release current (minimum current release)	1 A @ 50 and 100 Irated	0.030 A to 10.000 A	Increments of 0.001 A
	5 A @ 50 and 100 Irated	0.15 A to 50.00 A	Increments of 0.01 A
	1 A @ 1.6 Irated	0.001 A to 1.600 A	Increments of 0.001 A
	5 A @ 1.6 Irated	0.005 A to 8.000 A	Increments of 0.001 A
Maximum phase current (maximum current limiting)	1 A @ 50 and 100 Irated	0.030 A to 35.000 A	Increments of 0.001 A
	5 A @ 50 and 100 Irated	0.15 A to 175.00 A	Increments of 0.01 A
	1 A @ 1.6 Irated	0.001 A to 1.600 A	Increments of 0.001 A
	5 A @ 1.6 Irated	0.005 A to 8.000 A	Increments of 0.001 A

Dropout

The greater dropout differential (= | pickup value - dropout value |) of the following 2 criteria applies:

- Dropout differential derived from the parameter **Dropout ratio**
- Dropout differential of 3 % of the object rated current

Times

Pickup time	Approx. 40 ms + OOT ^{*)} at 50 Hz Approx. 35 ms + OOT at 60 Hz
Dropout time	Approx. 35 ms + OOT

Current Operating Range

Current range	At least one phase current \geq setting value $I_{release}$ All phase currents \leq setting value $I_{obj, max}$
---------------	---

Frequency Operating Range

$0.9 \leq f/f_{rated} \leq 1.1$	According to specified tolerances
$10 \text{ Hz} \leq f < 0.9 f_{rated}$	Slightly expanded tolerances
$1.1 f_{rated} < f \leq 80 \text{ Hz}$	
$f < 10 \text{ Hz}$ $f > 80 \text{ Hz}$	Inactive



* OOT (Output Operating Time) additional delay of the output medium used, see chapter 12.1.4 Relay Outputs

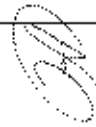

Tolerances

Pickup value	
$I_2/I_{rated, obj}$	Approx. 2 % of the setting value or 0.8 % of the absolute value
I_2/I_1	Approx. 2 % of the setting value or 4 % of the absolute value ($I_1 > 50 \text{ mA}$ ($I_{rated} = 1 \text{ A}$) or 250 mA ($I_{rated} = 5 \text{ A}$))
Time delays	1 % of the setting value or 10 ms

12.20.2 Stage with Inverse-Time Characteristic Curve

Setting Values

Reference value for $I_2 (I_{ref})$	Rated object current $I_{rated, obj}$ Positive-sequence current I_1		
Pickup value	5.0 % to 999.9 % I_2/I_{ref}	Increments of 0.1	
Dropout	Disk emulation Instantaneous		
Time multiplier	0.05 to 15.00	Increments of 0.01	
Release current (minimum current release)	1 A @ 50 and 100 Irated	0.030 A to 10.000 A	Increments of 0.001 A
	5 A @ 50 and 100 Irated	0.15 A to 50.00 A	Increments of 0.01 A
	1 A @ 1.6 Irated	0.001 A to 1.600 A	Increments of 0.001 A
	5 A @ 1.6 Irated	0.005 A to 8.000 A	Increments of 0.001 A
Maximum phase current (maximum current limiting)	1 A @ 50 and 100 Irated	0.030 A to 35.000 A	Increments of 0.001 A
	5 A @ 50 and 100 Irated	0.15 A to 175.00 A	Increments of 0.01 A
	1 A @ 1.6 Irated	0.001 A to 1.600 A	Increments of 0.001 A
	5 A @ 1.6 Irated	0.005 A to 8.000 A	Increments of 0.001 A

Dropout

The greater dropout differential (= | pickup value - dropout value |) of the following 2 criteria applies:

- Dropout differential derived from the parameter **Dropout ratio**
- Dropout differential of 3 % of the object rated current

Times

Pickup time	Approx. 40 ms + 0.01 ⁶⁶ at 50 Hz
	Approx. 35 ms + 0.01 at 60 Hz
Dropout time	Approx. 35 ms + 0.01

Dropout Ratio

Disk emulation	Approx. 0.90 · threshold value
Instantaneous	Approx. 1.05 · threshold value Approx. 0.95 · pickup value

⁶⁶ OOT (Output Operating Time); additional delay of the output medium used, see chapter 12.1.4 *Relay Outputs*

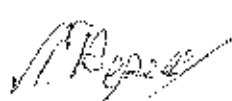

Operate and Dropout Characteristic Curves

You can select from the following operate and dropout characteristic curves:

Table 12-3 Standard Characteristic Curves to IEC

Normal inverse: type A	See chapter 12.5.2 Stage with Inverse Time Characteristic Curve, Figure 12-1
Very inverse: type B	
Extremely inverse: type C	See chapter 12.5.2 Stage with Inverse Time Characteristic Curve, Figure 12-2
Long-time inverse: type B	

Table 12-4 Standard Characteristic Curves to ANSI

Inverse: type C	See chapter 12.5.2 Stage with Inverse-Time Characteristic Curve, Figure 12-3
Short inverse	
Long inverse	See chapter 12.5.2 Stage with Inverse-Time Characteristic Curve, Figure 12-4
Moderately inverse	
Very inverse	See chapter 12.5.2 Stage with Inverse-Time Characteristic Curve, Figure 12-5
Extremely inverse	
Definite inverse	See chapter 12.5.2 Stage with Inverse-Time Characteristic Curve, Figure 12-6

Extension of the Operating Time

Extension of the operate time during operation with transformer inrush-current detection	Approx. 10 ms
--	---------------

Current Operating Range

Current range	At least one phase current \geq setting value $I_{release}$ All phase currents $<$ setting value $I_{ph, max}$
---------------	---

Frequency Operating Range

$0.9 \leq f/f_{rated} \leq 1.1$	According to specified tolerances
$10 \text{ Hz} \leq 0.9 I_{rated}$ $1.1 I_{rated} < f \leq 80 \text{ Hz}$	Slightly expanded tolerances
$f < 10 \text{ Hz}$ $f > 80 \text{ Hz}$	Inactive

Tolerances

Reference value = rated current	
Pickup value	Approx. 2 % of the setting value or 0.8 % of the absolute value
Operate time for $2 \leq I/I$ threshold value ≤ 20	5 % of the setting value or ± 2 % of the current tolerance or 30 ms
Dropout time for I/I threshold value ≤ 0.90	5 % of the setting value or ± 2 % of the current tolerance or 30 ms
Reference value = pos. seq. current	
Pickup value	Approx. 2 % of the setting value or 4 % of the absolute value ($I > 50 \text{ mA}$ ($I_{rated} = 1 \text{ A}$) or 250 mA ($I_{rated} = 5 \text{ A}$))

Technical Data

12.25 Negative-Sequence Protection

Operate time for $2 \times I/1$ threshold value ≤ 20	5 % of the reference (calculated) value + 2 % current tolerance or 30 ms
Dropout time for $I/1$ threshold value ≤ 0.90	5 % of the reference (calculated) value + 2 % current tolerance or 30 ms

12.21 Directional Negative-Sequence Protection with Definite-Time Delay

Setting Values

Directional mode	Forward, backward, non-directional	
Stabilization with phase currents	0 % to 30 %	Increments of 1 %
Threshold value (pickup value) at $I_{N-rated} = 1 \text{ A}$	0.030 A to 35.000 A	Increments of 0.001 A
Threshold value (pickup value) at $I_{N-rated} = 5 \text{ A}$	0.15 A to 175.00 A	Increments of 0.01 A
Extension time of the blocking after a 1-pole pause	0.00 s to 60.00 s	Increments of 0.01 s

Setting Values for Direction Determination

Minimum negative-sequence system voltage V_2	0.150 V to 20.000 V		Increments of 0.001 V
Minimum negative-sequence system current I_2	For $I_{rated} = 1 \text{ A}$	0.030 A to 30.000 A	Increments of 0.001 A
	For $I_{rated} = 5 \text{ A}$	0.15 A to 50.00 A	Increments of 0.01 A
Upper limit angle forward, β	0° to 360°		Increments of 1°
Lower limit angle forward, α	0° to 360°		Increments of 1°

Dropout

The greater dropout differential ($\sim | \text{pickup value} - \text{dropout value} |$) of the following 2 criteria applies:

- Dropout differential derived from the parameter **Dropout ratio**
- Dropout differential of 3 % of the object rated current

Times

Operate time with time delay = 0 ms	Approx. 40 ms + OOT** at 50 Hz Approx. 40 ms + OOT at 60 Hz
Dropout time	Approx. 39 ms + OOT

Frequency Operating Range

$0.9 \leq f/f_{rated} \leq 1.1$	According to specified tolerances
$10 \text{ Hz} < f < 0.9 f_{rated}$ $1.1 f_{rated} < f \leq 80 \text{ Hz}$	Slightly expanded tolerances
$f < 10 \text{ Hz}$ $f > 80 \text{ Hz}$	Inactive

Tolerances

Threshold values:	
Negative-sequence voltage V_2	1 % of the setting value or 0.5 V
Negative-sequence current I_2	2 % of the setting value or 10 mA at $I_{rated} = 1 \text{ A}$
	1 % of the setting value or 5 mA at $I_{rated} = 5 \text{ A}$
Times:	
Independent time delays	1 % of the setting value or 10 ms

** OOT (Output Operating Time) additional delay of the output medium used, see chapter 12.1.4 Relay Outputs

Technical Data

12.21 Directional Negative-Sequence Protection with Definite-Time Delay

Limit angle in determining the direction	5°
--	----

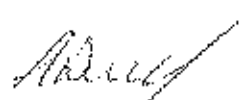

12.22 Thermal Overload Protection, 3-Phase



Setting Value for the Function Block Filter

h(0)	-100.000 to 100.000	Increments of 0.001
h(1)	-100.000 to 100.000	Increments of 0.001
h(2)	-100.000 to 100.000	Increments of 0.001
h(3)	-100.000 to 100.000	Increments of 0.001
h(4)	-100.000 to 100.000	increments of 0.001

Setting Values/Increments for the Protection Stage

Threshold current warning	1 A @ 50 and 100 Irated	0.030 A to 35.000 A	Increments of 0.001 A
	5 A @ 50 and 100 Irated	0.15 A to 175.00 A	Increments of 0.01 A
	1 A @ 1.6 Irated	0.001 A to 1.600 A	Increments of 0.001 A
	5 A @ 1.6 Irated	0.005 A to 8.000 A	Increments of 0.001 A
Threshold thermal warn.		50 % to 100 %	Increments of 1 %
Dropout threshold operate		50 % to 99 %	Increments of 1 %
Emerg. start / overtravel		0 s to 15.000 s	Increments of 10 s
K-factor acc. to IEC 60225-8		0.10 to 4.00	Increments of 0.01
Thermal time constant		10 s to 60.000 s	Increments of 1 s
Cooling time constant		10 s to 60.000 s	Increments of 1 s
I _{max} thermal	1 A @ 50 and 100 Irated	0.030 A to 10.000 A	increments of 0.001 A
	5 A @ 50 and 100 Irated	0.15 A to 50.00 A	increments of 0.01 A
	1 A @ 1.6 Irated	0.001 A to 1.600 A	Increments of 0.001 A
	5 A @ 1.6 Irated	0.005 A to 8.000 A	Increments of 0.001 A
I _{min} cooling	1 A @ 50 and 100 Irated	0.000 A to 10.000 A	Increments of 0.001 A
	5 A @ 50 and 100 Irated	0.00 A to 50.00 A	Increments of 0.01 A
	1 A @ 1.6 Irated	0.000 A to 1.600 A	Increments of 0.001 A
	5 A @ 1.6 Irated	0.000 A to 8.000 A	Increments of 0.001 A
Temperature rise at Irated		40 K to 200 K	Increments of 1 K
Default temperature		-55°C to 55°C	Increments of 1°C
Minimal temperature		-55°C to 40°C	Increments of 1°C

Dropout Ratios

Tripping threshold (fixed at 100 %)	Dropout if value drops below operate indication dropout threshold
Thermal warning threshold	About 0.99 of the setting value
Current warning threshold	About 0.95 of the setting value

Frequency Range of the Input Signals

The function captures input signals up to the 50th harmonic.

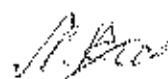



Tolerances

No filter applied (33 % harmonics, in relation to the fundamental component)		
With reference to $k \cdot I_{rated}$	Up to 30th harmonic	2 % or 10 mA ($I_{rated} = 1$ A) or 50 mA ($I_{rated} = 5$ A), 2 % class acc. to IEC 60255-8
	Up to 50th harmonic, $f_{rated} = 50$ Hz	4 % or 20 mA ($I_{rated} = 1$ A) or 100 mA ($I_{rated} = 5$ A), 4 % class acc. to IEC 60255-8
	Up to 50th harmonic, $f_{rated} = 60$ Hz	5 % or 25 mA ($I_{rated} = 1$ A) or 125 mA ($I_{rated} = 5$ A), 5 % class acc. to IEC 60255-8
With the filter for compensation of the amplitude attenuation due to the anti-aliasing filter (33 % harmonics, in relation to the fundamental component)		
With reference to $k \cdot I_{rated}$	Up to 30th harmonic	2 % or 10 mA ($I_{rated} = 1$ A) or 50 mA ($I_{rated} = 5$ A), 2 % class acc. to IEC 60255-8
	Up to 50th harmonic, $f_{rated} = 50$ Hz	3 % or 20 mA ($I_{rated} = 1$ A) or 100 mA ($I_{rated} = 5$ A), 3 % class acc. to IEC 60255-8
	Up to 50th harmonic, $f_{rated} = 60$ Hz	4 % or 20 mA ($I_{rated} = 1$ A) or 100 mA ($I_{rated} = 5$ A), 4 % class acc. to IEC 60255-8
With the filter for gain of harmonics including compensation of the amplitude attenuation⁸⁸ (33 % harmonics, in relation to the fundamental component)		
With reference to $k \cdot I_{rated}$	Up to 30th harmonic	2 % or 10 mA ($I_{rated} = 1$ A) or 50 mA ($I_{rated} = 5$ A), 2 % class acc. to IEC 60255-8 ⁸⁹
	Up to 50th harmonic, $f_{rated} = 50$ Hz	4 % or 20 mA ($I_{rated} = 1$ A) or 100 mA ($I_{rated} = 5$ A), 4 % class acc. to IEC 60255-8 ⁹⁰
	Up to 50th harmonic, $f_{rated} = 60$ Hz	5 % or 25 mA ($I_{rated} = 1$ A) or 125 mA ($I_{rated} = 5$ A), 5 % class acc. to IEC 60255-8 ⁹⁰
With reference to the operate time	Up to 30th harmonic	3 % or 1 s for $I(k \cdot I_{rated}) > 1.25$, 3 % class acc. to IEC 60255-8

Operate Curve

Operate curve	$t = \tau_{th} \cdot \ln \frac{\left(\frac{1}{k \cdot I_{rated,obj}} \right)^2 \left(\frac{I_{preload}}{k \cdot I_{rated,obj}} \right)^2}{\left(\frac{1}{k \cdot I_{rated,obj}} \right)^2 - 1}$	
Where	t	Operate time
	τ_{th}	Time constant
	I	Current load current
	$I_{preload}$	Preload current
	k	Setting factor according to VDE 0435 part 3011 or IEC 60255-8 (K factor)
	$I_{rated,obj}$	Rated current of the protected object



⁸⁸ In case that the filter response exactly matches the user-defined gain factor.

⁸⁹ In case that the user-defined gain factor is set below 3. The tolerance is increased if the gain factor is larger.

⁹⁰ In case that the user-defined gain factor is set below 7. The tolerance is increased if the gain factor is larger.

A. Repp

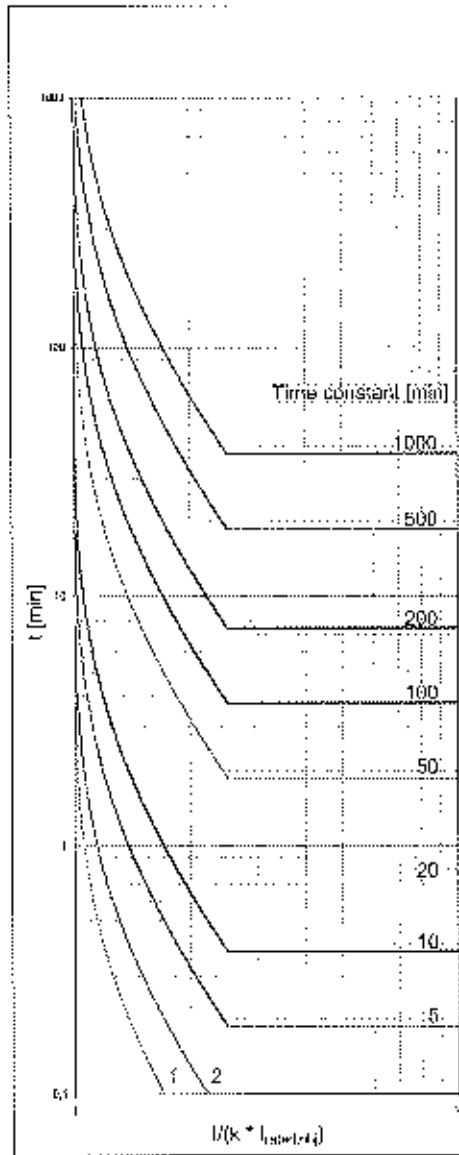

With 80 % preload and with $I_{max, therm} = 2.5 \cdot k \cdot I_{rated}$

$$t = \tau_{th} \cdot \ln \frac{\left(\frac{1}{k \cdot I_{rated,obj}} \right)^2 - \left(\frac{I_{preload}}{k \cdot I_{rated,obj}} \right)^2}{\left(\frac{1}{k \cdot I_{rated,obj}} \right)^2 - 1} \quad [\text{min}]$$

[Example: 1000/1000/1000, 1000]

Figure 12-15 Operate Curve of Overload Protection

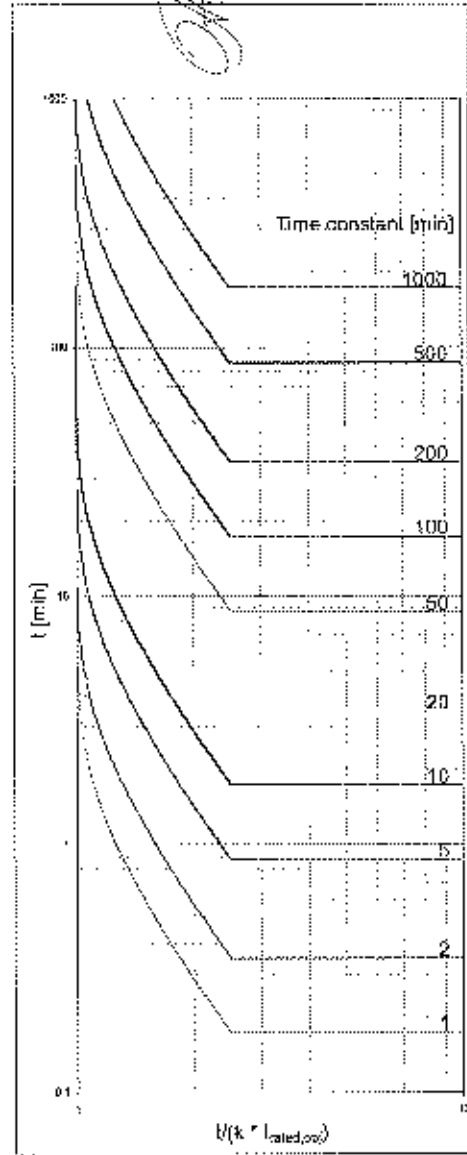

Without preload and with $I_{max, therm} = 2.5 \cdot k \cdot I_{rated}$

$$t = \tau_{th} \cdot \ln \frac{\left(\frac{I}{k \cdot I_{rated,obj}} \right)^2}{\left(\frac{1}{k \cdot I_{rated,obj}} \right)^2 - 1} \quad [\text{min}]$$

A. K. ...

...



12.23 Thermal Overload Protection, User-Defined Characteristic Curve

Setting Values

Threshold current warning	1 A @ 50 and 100 I _{rated}	0.030 A to 35.000 A	Increments of 0.001 A
	5 A @ 50 and 100 I _{rated}	0.15 A to 175.00 A	Increments of 0.01 A
	1 A @ 1.6 I _{rated}	0.001 A to 1.600 A	Increments of 0.001 A
	5 A @ 1.6 I _{rated}	0.005 A to 8.000 A	Increments of 0.001 A
Threshold thermal warn.		50 % to 100 %	Increments of 1 %
Dropout threshold operate		50 % to 99 %	Increments of 1 %
Emerg. start T overtravel		0 s to 15.000 s	Increments of 10 s
I _{max} thermal	1 A @ 50 and 100 I _{rated}	0.030 A to 10.000 A	Increments of 0.001 A
	5 A @ 50 and 100 I _{rated}	0.15 A to 50.00 A	Increments of 0.01 A
	1 A @ 1.6 I _{rated}	0.001 A to 1.600 A	Increments of 0.001 A
	5 A @ 1.6 I _{rated}	0.005 A to 8.000 A	Increments of 0.001 A
I _{min} cooling	1 A @ 50 and 100 I _{rated}	0.000 A to 10.000 A	Increments of 0.001 A
	5 A @ 50 and 100 I _{rated}	0.00 A to 50.00 A	Increments of 0.01 A
	1 A @ 1.6 I _{rated}	0.000 A to 1.600 A	Increments of 0.001 A
	5 A @ 1.6 I _{rated}	0.000 A to 8.000 A	Increments of 0.001 A
Curve based on preload		1 % to 100 %	Increments of 1 %
Number of value pairs for the operate curve		2 to 30	Increments of 1
X values of the operate curve		1.10 p.u. to 20.00 p.u.	Increments of 0.0 p.u.
Y values of the operate curve		1.00 s to 20.000.00 s	Increments of 0.01 s

Dropout Ratios

Tripping threshold (fixed at 100 %)	Dropout if value drops below operate indication dropout threshold
Thermal warning threshold	About 0.99 of the setting value
Current warning threshold	About 0.95 of the setting value

Frequency Range of the Input Signals

The function captures input signals up to the 50th harmonic.

Tolerances

With reference to $k \cdot I_{rated}$	For $I_{rated} = 1$ A	2 % or 10 mA, class 2 % acc. to IEC 60255-8
	For $I_{rated} = 5$ A	2 % or 50 mA, class 2 % acc. to IEC 60255-8
With reference to operate time		3 % or 1 s, class 3 % acc. to IEC 60255-8 for $I(k \cdot I_{rated}) > 1.25$

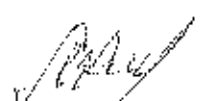



12.24 Unbalanced-Load Protection

Setting Values

Maximum continuously perm. I ₂	3.0 % to 30.0 % I ₂ ⁿ I _{rated, machine}	Increments of 0.1 %
Unbalanced load factor K	1.0 s to 100.0 s	Increments of 0.1 s
Warning delay	0.0 s to 60.0 s; ∞	Increments of 0.1 s
Cooling time thermal replica	0 s to 50 000 s	Increments of 1 s

Dropout

The greater dropout differential (= | pickup value - dropout value |) of the following 2 criteria applies:

- Dropout differential derived from a dropout ratio of 95 %
- Dropout differential of 3 % of the object rated current

Operate Characteristics

Characteristic of the thermal replica	$t_{12perm} = \frac{K}{\left(\frac{I_2}{I_{rated, machine}}\right)^2}$	
Where:	t _{12perm}	Permissible application time of the negative-sequence current
	K	Unbalanced load factor K
	I ₂ ⁿ _{rated, machine}	Unbalanced load (negative-sequence current/rated current of the machine)

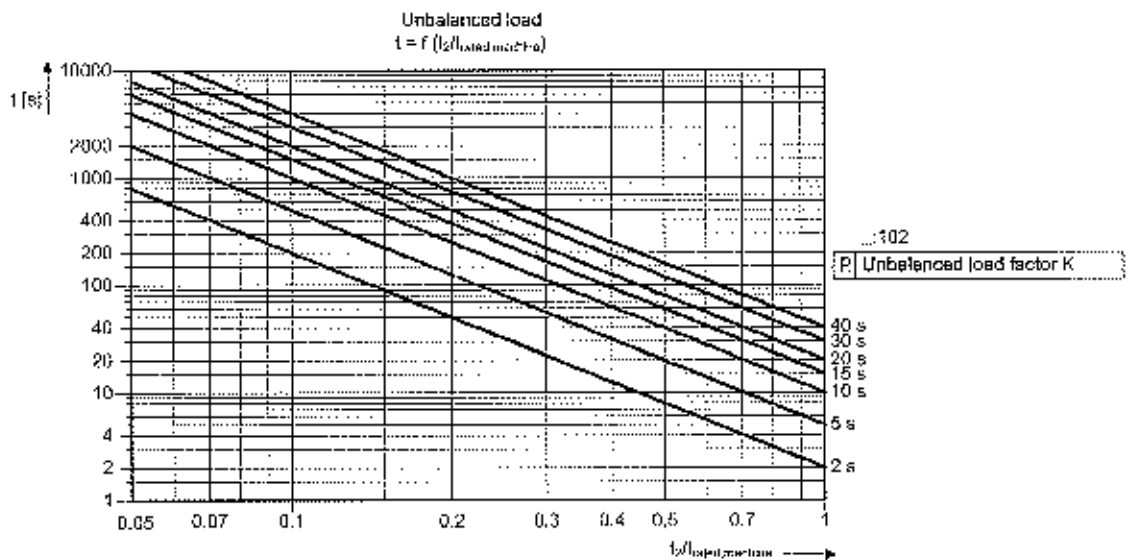

Standard: 800013, 1.01, LSI

Figure 12-16 Thermal Characteristic for Unbalanced Load Protection

Times

Pickup time of the warning stage	Approx. 60 ms + OOT ⁹¹ at 50 Hz Approx. 50 ms + OOT at 60 Hz
----------------------------------	--

⁹¹ OOT (Output Operating Time) additional delay of the output medium used, for example, 5 ms with fast relays

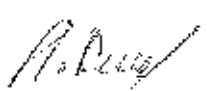
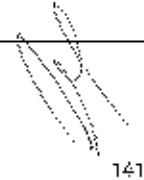

Dropout time	Approx. 50 ms or better
--------------	-------------------------

Frequency Operating Range

$0.9 \leq f/f_{rated} \leq 1.1$	According to specified tolerances
$10 \text{ Hz} \leq f < 0.9 f_{rated}$	Slightly expanded tolerances
$1.1 f_{rated} < f \leq 80 \text{ Hz}$	
$f < 10 \text{ Hz}$	inactive
$f > 80 \text{ Hz}$	

Tolerances

Negative-sequence current I_2	Approx. 3 % of setting value or 0.030 A at $I_{rated} = 1 \text{ A}$ Approx. 3 % of setting value or 0.150 A at $I_{rated} = 5 \text{ A}$
Warning delay	1 % of the setting value or 10 ms
Time for $2 \leq I_2/I_{2perm} < 20$	5 % of reference (calculated) value or 300 ms \pm (1 % current tolerance or 10 mA) at $I_{rated} = 1 \text{ A}$ 5 % of reference (calculated) value or 100 ms \pm (1 % current tolerance or 50 mA) at $I_{rated} = 5 \text{ A}$

Influencing Variables for the Thresholds

Harmonics	
– Up to 10 % 3rd harmonic	$\leq 1 \%$
Up to 10 % 5th harmonic	$\leq 1 \%$



12.25 Current-Unbalance Protection for Capacitors, 3-Phase

Setting Values for the Function

Automatic compensation		Yes No	
Time between switch off and switch on		0.00 s to 60.00 s	Increments of 0.01 s
Normalization with I _c		Yes No	
Threshold of defective Element	1 A @ 50 and 100 Irated	0.030 A to 35.000 A	Increments of 0.001 A
	5 A @ 50 and 100 Irated	0.15 A to 175.00 A	Increments of 0.01 A
	1 A @ 1.6 Irated	0.001 A to 1.600 A	Increments of 0.001 A
	5 A @ 1.6 Irated	0.005 A to 8.000 A	Increments of 0.001 A

Setting Values (Overcurrent-Protection Stage I>)

Measured value		compensated non-compensated	
I _{unbal.}	1 A @ 50 and 100 Irated	0.030 A to 35.000 A	Increments of 0.001 A
	5 A @ 50 and 100 Irated	0.15 A to 175.00 A	Increments of 0.01 A
I _{unbal.}	1 A @ 1.6 Irated	0.001 A to 1.600 A	Increments of 0.001 A
	5 A @ 1.6 Irated	0.005 A to 8.000 A	Increments of 0.001 A
Operate delay		0.00 s to 60.00 s	Increments of 0.01 s

Setting Values (Counter Stage)

Type of counting groups	segregated sum	
Max. no. of def. elem. phs A	1 to 1000	Increments of 1
Max. no. of def. elem. phs B	1 to 1000	Increments of 1
Max. no. of def. elem. phs C	1 to 1000	Increments of 1
Operate delay	0.00 s to 10000.00 s	Increments of 0.01 s

Dropout

The greater dropout differential (= | pickup value - dropout value |) of the following 2 criteria applies:

Dropout differential derived from the parameter Dropout ratio if this parameter is not available, a dropout ratio of 95 % applies for overcurrent and of 105 % for undercurrent functionality.	
Minimum absolute dropout differential	
Protection-class current transformer	15 mA sec. (I _{rated} = 1 A) or 75 mA sec. (I _{rated} = 5 A)
Instrument current transformer	0.5 mA sec. (I _{rated} = 1 A) or 2.5 mA sec. (I _{rated} = 5 A)

Times

Operate time with time delay – 0 ms	Approx. 32 ms + OOT ⁹² at 50 Hz Approx. 29 ms + OOT at 60 Hz
-------------------------------------	--

⁹² OOT (Output Operating Time) additional delay of the output medium used, see chapter 12.1.4 Relay Outputs

A. Bell

Dropout time	Approx. 32 ms + OOT at 50 Hz Approx. 27 ms + OOT at 60 Hz
--------------	--

Frequency Operating Range

$0.9 \leq f/f_{rated} \leq 1.1$	According to specified tolerances
$10 \text{ Hz} \leq f < 0.9 f_{rated}$ $1.1 f_{rated} < f \leq 80 \text{ Hz}$	Slightly expanded tolerances
$f < 10 \text{ Hz}$ $f > 80 \text{ Hz}$	Active

Tolerances

Currents I_{unbal} , Protection-class current transformers	1 % of the setting value or 5 mA ($I_{rated} = 1 \text{ A}$) or 25 mA ($I_{rated} = 5 \text{ A}$), ($f_{rated} \pm 10 \%$)
Currents I_{unbal} , Sensitive current transformer	1 % of the setting value or 0.1 mA ($I_{rated} = 1.6 \text{ A}$) or 0.5 mA ($I_{rated} = 8 \text{ A}$), ($f_{rated} \pm 10 \%$)
Time delays	1 % of the setting value or 10 ms



12.26 Current-Unbalance Protection for Capacitors, 1-Phase

Setting Values for the Function

Automatic compensation	Yes No		
Time between switch off and switch on	0.00 s to 60.00 s	Increments of 0.01 s	
Normalization with I_c	Yes No		
Threshold of defective C-element	1 A @ 50 and 100 Irated	0.030 A to 35.000 A	Increments of 0.001 A
	5 A @ 50 and 100 Irated	0.15 A to 175.00 A	Increments of 0.01 A
	1 A @ 1.6 Irated	0.001 A to 1.600 A	Increments of 0.001 A
	5 A @ 1.6 Irated	0.005 A to 8.000 A	Increments of 0.001 A

Setting Values (Overcurrent-Protection Stage I-)

Current threshold I_{unbal}	1 A @ 50 and 100 Irated	0.030 A to 35.000 A	Increments of 0.001 A
	5 A @ 50 and 100 Irated	0.150 A to 175.000 A	Increments of 0.01 A
	1 A @ 1.6 Irated	0.001 A to 1.600 A	Increments of 0.001 A
	5 A @ 1.6 Irated	0.005 A to 8.000 A	Increments of 0.005 A
Operate delay		0.00 s to 60.00 s	increments of 0.01 s
Measured value			compensated non compensated

Setting Values (Counter Stage)

Type of counting groups		segregated sum
Type of counting phases		segregated sum
Max. no. of def. elem. phs A	1 to 1000	Increments of 1
Max. no. of def. elem. phs B	1 to 1000	Increments of 1
Max. no. of def. elem. phs C	1 to 1000	Increments of 1
Max. no. of def. elem.	1 to 1000	Increments of 1
Operate delay	0.00 s to 10000.00 s	Increments of 0.01 s

Dropout

The greater dropout differential (= | pickup value - dropout value |) of the following 2 criteria applies:

Dropout differential derived from the parameter Dropout ratio	
If this parameter is not available, a dropout ratio of 95 % applies for overcurrent and of 105 % for undercurrent functionality.	
Minimum absolute dropout differential	
Protection-class current transformer	15 mA sec. ($I_{rated} = 1 A$) or 75 mA sec. ($I_{rated} = 5 A$)
Instrument current transformer	0.5 mA sec. ($I_{rated} = 1 A$) or 2.5 mA sec. ($I_{rated} = 5 A$)



A. Reif

Times

Operate time with time delay = 0 ms	Approx. 32 ms + OOT ⁹³ at 50 Hz Approx. 29 ms + OOT ⁹³ at 60 Hz
Dropout time	Approx. 32 ms + OOT at 50 Hz Approx. 27 ms + OOT at 60 Hz

Frequency Operating Range

$0.9 \leq f/f_{rated} \leq 1.1$	According to specified tolerances
$10 \text{ Hz} \leq f < 0.9 f_{rated}$ $1.1 f_{rated} < f \leq 80 \text{ Hz}$	Slightly expanded tolerances
$f < 10 \text{ Hz}$ $f > 80 \text{ Hz}$	Active

Tolerances

Currents I_c, I_{unbal} Protection-class current transformers	1 % of the setting value or 5 mA ($I_{rated} = 1 \text{ A}$) or 25 mA ($I_{rated} = 5 \text{ A}$), ($f_{rated} \pm 10\%$)
Currents I_{unbal} Sensitive current transformer	1 % of the setting value or 0.1 mA ($I_{rated} = 1.6 \text{ A}$) or 0.5 mA ($I_{rated} = 8 \text{ A}$), ($f_{rated} \pm 10\%$)
Time delays	1 % of the setting value or 10 ms

⁹³OOT (Output Operating Time) additional delay of the output medium used, see chapter 12.1.4 Relay Outputs

12.27 Voltage-Differential Protection for Capacitor Banks

Setting Values (General Functionality)

Voltage matching factor k	0.5000 to 2000.0000	increments of 0.0001
---------------------------	---------------------	----------------------

Setting Values (Protection Stage $V_{diff}>$)

Threshold	0.005 p.u. to 1.000 p.u. ^{*)}	increments of 0.001 p.u.
Operate delay	0.00 s to 60.00 s	increments of 0.01 s

Dropout

Dropout ratio for sec. threshold ≥ 3 V	95 %
Dropout differential for sec. threshold 0.3 V to 3 V	150 mV
Dropout ratio for sec. threshold 0.2 V to 0.3 V	50 %

Times

Operate time with time delay = 0 ms	Approx. 30 ms + OOT (Output Operating Time) at 50 Hz Approx. 27 ms + OOT (Output Operating Time) at 60 Hz
Dropout time	Approx. 20 ms + OOT (Output Operating Time) at 50 Hz Approx. 18 ms + OOT (Output Operating Time) at 60 Hz

Tolerances

Threshold ≥ 0.2 V	1 % of the setting value or 0.05 V (compensated)
Time delays	1 % of the setting value or 10 ms

Operating Range of the Secondary Differential Voltage

Operating Range of the secondary differential voltage	> 0.1 V (compensated)
---	-------------------------

Frequency Operating Range

$0.9 \leq f_{rated} \leq 1.1$	According to specified tolerances
$10 \text{ Hz} \leq f < 0.9 f_{rated}$ $1.1 f_{rated} < f \leq 80 \text{ Hz}$	Slightly expanded tolerances
$f < 10 \text{ Hz}$ $f > 80 \text{ Hz}$	Active

*) Minimum secondary setting threshold = 0.2 V

Handwritten signature

Handwritten signature

12.28 Differential Protection for Capacitor Banks

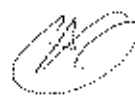

Setting Values

Operate Curve			
Threshold value	$I_{th}^{(rated)}$	0.05 to 2.00	Increments of 0.01
Gradient 1		0.00 to 0.80	Increments of 0.01
Intersection 1 I_{res1}	$I_{res1}^{(rated)}$	0.00 to 5.00	Increments of 0.01
Gradient 2		0.25 to 0.95	Increments of 0.01
Intersection 2 I_{res2}	$I_{res2}^{(rated)}$	1.00 to 20.00	Increments of 0.01
Startup Recognition			
Startup threshold value	$I_{st}^{(rated)}$	0.1 to 2.0	Increments of 0.1
Characteristic-curve increase factor		1.0 to 5.0	Increments of 0.1
Maximum starting time		0.1 s to 180.0 s	Increments of 0.1 s
DC-Component Recognition			
Characteristic-curve increase factor DC		1.0 to 5.0	Increments of 0.1
Inrush-current detection			
Content 2nd harmonic		10 % to 45 %	Increments of 1 %
Duration of crossblk. 2. har.		0.00 s to 200.00 s or ∞	Increments of 0.01 s
Recognition of External Faults			
Additional stabilization threshold value	$I_{st}^{(rated)}$	1.00 to 20.00	Increments of 0.01
Additional stabilization duration		0.00 s to 5.00 s or ∞	Increments of 0.01 s
Operate curve		See Figure 12-17	

Idiff Fast

Threshold value	$I_{diff}^{(rated)}$	0.5 to 35.0	Increments of 0.1
Tripping delay		0.00 s to 60.00 s	Increments of 0.01 s

Dropout Ratio

Idiff stage	Approx. 0.7
Idiff fast stage	Approx. 0.8

Response Tolerance

For preset characteristic-curve parameters; for 2 sides with one measuring point each	
Idiff stage and characteristic curve	2 % of the setting value
Idiff fast stage	2 % of the setting value

Time Delays

Idiff stage	0.00 s to 60.00 s	Increments of 0.01 s
Idiff fast stage	0.00 s to 60.00 s	Increments of 0.01 s
Timer tolerance	1 % of the setting value or 10 ms	

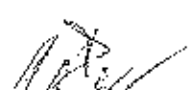

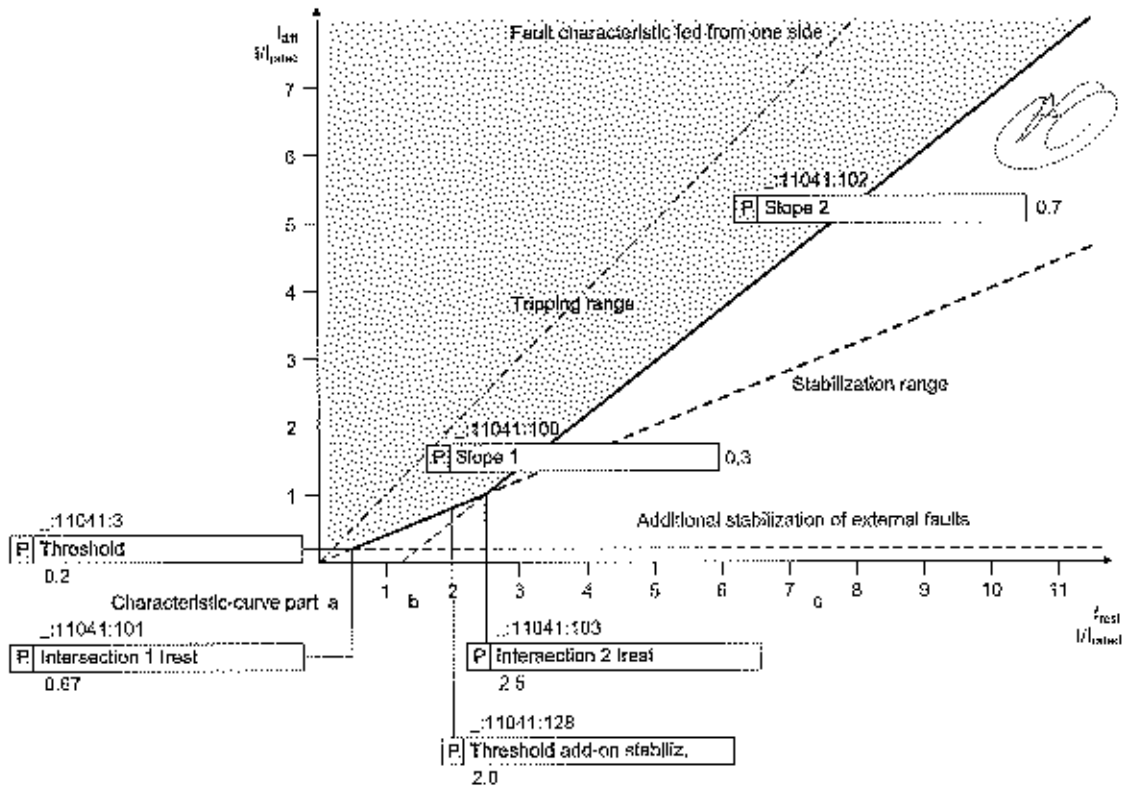

Figure 12-17 Operate Curve of the Differential Protection

Operating Times

Operate times for infeed on one side		
Idiff stage, min	50 Hz	23 ms + OOT ⁹⁵
	60 Hz	20 ms + OOT ¹⁾
Idiff fast stage, min	50 Hz	8 ms + OOT ¹⁾
	60 Hz	8 ms + OOT ¹⁾
Dropout time, approx.	50 Hz	29 ms
	60 Hz	26 ms

Frequency Operating Range

$0,9 \leq f/f_{rated} \leq 1,1$	According to specified tolerances
$10 \text{ Hz} \leq f < 0,9 f_{rated}$	Slightly expanded tolerances
$1,1 f_{rated} < f \leq 80 \text{ Hz}$	
$f < 10 \text{ Hz}$	Active
$f > 80 \text{ Hz}$	

⁹⁵ Refer to protection functions, for example, Overcurrent protection

A. Rost

OK

12.29 Overvoltage Protection with 3-Phase Voltage

Setting Values for Stage Type Definite Time-Overvoltage Protection

Measured value	Phase-to-phase Phase-to-ground	
Method of measurement	Fundamental component RMS value	
Pickup mode	1 out of 3 3 out of 3	
Pickup value ⁶⁶	0.300 V to 340.000 V	Increments of 0.001 V
Time delay	0.00 s to 300.00 s	Increments of 0.01 s
Dropout ratio	0.90 to 0.99	Increments of 0.01

Setting Values for Stage Type Inverse Time-Overvoltage Protection

Measured value	Phase-to-phase Phase-to-ground	
Method of measurement	Fundamental component RMS value	
Pickup mode	1 out of 3 3 out of 3	
Pickup value	0.300 V to 340.000 V	increments of 0.001 V
Pickup factor	1.00 to 1.20	increments of 0.01
Characteristic constant k	0.00 to 300.00	increments of 0.01
Characteristic constant n	0.010 to 5.000	increments of 0.001
Characteristic constant c	0.000 to 5.000	increments of 0.001
Time multiplier	0.05 to 15.00	increments of 0.01
Additional time delay	0.00 s to 60.00 s	increments of 0.01 s
Reset time	0.00 s to 60.00 s	increments of 0.01 s

Operate Curve for Stage Type Inverse Time-Overvoltage Protection

$$T_{op} = T_{inv} + T_{add}$$

Where

T_{op} Operate delay

T_{inv} Inverse-time delay

T_{add} Additional time delay (parameter **Additional time delay**)

$$T_{inv} = T_n \left(\frac{k}{\left(\frac{V}{V_{thresh}} \right)^n - 1} + c \right) [s]$$

Where

T_{inv} Inverse-time delay

T_n Time multiplier (parameter **Time dial**)

V Measured voltage

⁶⁶If you have selected the method of measurement – RMS value, do not set the threshold value under 10 V.

A. Paul

M

V_{thresh}	Threshold value (parameter Threshold)
k	Curve constant k (parameter Charact. constant k)
a	Curve constant a (parameter Charact. constant a)
c	Curve constant c (parameter Charact. constant c)



Dropout

The greater dropout differential (= | pickup value - dropout value |) of the following 2 criteria applies:

Dropout differential derived from the parameter Dropout ratio If this parameter is not available, a dropout ratio of 95 % applies for the overvoltage and of 105 % for the undervoltage functionality.	
Minimum absolute dropout differential	150 mV sec.

Times

Operate time with time delay = 0 ms	Approx. 25 ms + OOT ⁹² at 50 Hz Approx. 22 ms + OOT at 60 Hz
Dropout time	Approx. 20 ms + OOT

Frequency Operating Range

$0.9 \leq f/f_{\text{rated}} \leq 1.1$	According to specified tolerances
$10 \text{ Hz} \leq f < 0.9 f_{\text{rated}}$ $1.1 f_{\text{rated}} < f \leq 80 \text{ Hz}$	Slightly expanded tolerances
$f < 10 \text{ Hz}$ $f > 80 \text{ Hz}$	Active

Tolerances for Stage Type Definite Time-Overvoltage Protection

Voltages	0.5 % of the setting value or 0.05 V
Time delays	1 % of the setting value or 10 ms

Tolerances for Stage Type Inverse Time-Overvoltage Protection

Voltages	0.5 % of the setting value or 0.05 V
Operate time for $1.2 \leq V/V$ threshold value < 2.0	5 % of the setting value or 30 ms
Reset time delay	1 % of the setting value or 10 ms

⁹² OOT (Output Operating Time) additional delay of the output medium used, see chapter 12.1.4 Relay Outputs



12.30 Overvoltage Protection with Zero-Sequence Voltage/Residual Voltage

Setting Values

Method of Measurement	RMS value Fundamental component Fundamental component over 2 cycle filters	
Block. on measuring-voltage outage	Yes No	
Determ. ph. aff. by grd. flt.	Yes No	
Threshold value ⁹⁸	0.300 V to 340.000 V	Increments of 0.001 V
Time delay	0.00 s to 60.00 s	Increments of 0.01 s
Pickup delay	0.00 s to 320.00 s	Increments of 0.01 s
Dropout Ratio	0.90 to 0.99	Increments of 0.01
V< faulty ph-gnd. vltg.	0.300 V to 200.000 V	Increments of 0.001 V
V> healthy ph-gnd. vltg.	0.300 V to 200.000 V	Increments of 0.001 V

Dropout

The greater dropout differential (– | pickup value – dropout value |) of the following 2 criteria applies:

Dropout differential derived from the parameter Dropout ratio	
If this parameter is not available, a dropout ratio of 95 % applies for the overvoltage and of 105 % for the undervoltage functionality.	
Minimum absolute dropout differential	150 mV sec.

Times

Operate time with time delay = 0 ms	
Standard filter, true RMS	Approx. 25 ms + OOT ⁹⁹ at 50 Hz Approx. 22 ms + OOT at 60 Hz
2 cycle filters	Approx. 45 ms + OOT at 50 Hz Approx. 39 ms + OOT at 60 Hz
Dropout Time	
Standard filter, true RMS	Approx. 20 ms + OOT at 50 Hz Approx. 16.6 ms + OOT at 60 Hz
2 cycle filters	Approx. 31.06 ms + OOT at 50 Hz Approx. 27.06 ms + OOT at 60 Hz

Frequency Operating Range

$0.9 \leq 1f_{rated} < 1.1$	According to specified tolerances
$10 \text{ Hz} \leq f < 0.9 f_{rated}$	Slightly expanded tolerances
$1.1 f_{rated} < f \leq 80 \text{ Hz}$	

⁹⁸ If you have selected the method of measurement = RMS value, do not set the threshold value under 50 V.

⁹⁹ OOT (Output Operating Time) additional delay of the output medium used, see Chapter 12.1.4 Relay Outputs

M. Reuss

f < 10 Hz f > 80 Hz	Active
------------------------	--------

Tolerances

Voltages	0.5 % of the setting value or 0.05 V
Time delays	1 % of the setting value or 10 ms

12.31 Overvoltage Protection with Positive-Sequence Voltage

Setting Values

Pickup value	0.300 V to 200.000 V	Increments of 0.001 V
Time delay	0.00 s to 60.00 s	Increments of 0.01 s
Dropout ratio	0.90 to 0.99	Increments of 0.01

Dropout

The greater dropout differential (= | pickup value - dropout value |) of the following 2 criteria applies:

Dropout differential derived from the parameter Dropout ratio	
If this parameter is not available, a dropout ratio of 95 % applies for the overvoltage and of 105 % for the undervoltage functionality.	
Minimum absolute dropout differential	150 mV sec.

Times

Operate time with time delay = 0 ms	Approx. 25 ms + OOT ¹⁰⁾ at 50 Hz Approx. 22 ms + OOT at 60 Hz
Dropout time	Approx. 20 ms + OOT

Frequency Operating Range

$0.9 \leq f/f_{rated} \leq 1.1$	According to specified tolerances
$10 \text{ Hz} \leq f < 0.9 f_{rated}$	Slightly expanded tolerances
$1.1 f_{rated} < f \leq 80 \text{ Hz}$	
$f < 10 \text{ Hz}$	Active
$f > 80 \text{ Hz}$	

Tolerances

Voltages	0.5 % of the setting value or 0.05 V
Time delays	1 % of the setting value or 10 ms

¹⁰⁾ OOT (Output Operating Time) additional delay of the output medium used, see Chapter 12.1.4 Relay Outputs

12.32 Overvoltage Protection with Negative-Sequence Voltage

Setting Values for the Function

Measuring window	1 cycle to 10 cycles	Increments of 1 cycle
------------------	----------------------	-----------------------

Setting Values

Pickup value of V2	0.300 V to 200.000 V	Increments of 0.001 V
Operate delay	0.00 s to 60.00 s	Increments of 0.01 s
Dropout ratio	0.90 to 0.99	Increments of 0.01

Dropout

The greater dropout differential (= | pickup value - dropout value |) of the following 2 criteria applies:

Dropout differential derived from the parameter Dropout ratio	
If this parameter is not available, a dropout ratio of 95 % applies for the overvoltage and of 105 % for the undervoltage functionality.	
Minimum absolute dropout differential	150 mV sec.

Times

Pickup times	55 ms to 210 ms + OOT ¹⁰⁾ (depends on the measuring-window length) at 50 Hz 48 ms to 185 ms + OOT (depends on the measuring-window length) at 60 Hz
Dropout time	20 ms to 70 ms + OOT (depends on the measuring-window length)

Frequency Operating Range

$0.9 \leq f/f_{rated} \leq 1.1$	According to specified tolerances
$10 \text{ Hz} \leq f < 0.9 f_{rated}$	Slightly expanded tolerances
$1.1 f_{rated} < f \leq 80 \text{ Hz}$	
$f < 10 \text{ Hz}$ $f > 80 \text{ Hz}$	Inactive

Tolerances

Voltages	0.50 % of the setting value or 0.050 V
Time delays	1.00 % of the setting value or 10 ms

¹⁰⁾ OOT (Output Operating Time) additional delay of the output medium used, for example 5 ms with fast relays

A. Reed

W

12.33 Overvoltage Protection with Any Voltage

Setting Values

Measured value ¹⁰²	Measured phase-to-ground voltage V_A Measured phase-to-ground voltage V_B Measured phase-to-ground voltage V_C Measured phase-to-phase voltage V_{AB} Measured phase-to-phase voltage V_{BC} Measured phase-to-phase voltage V_{CA} Measured phase-to-phase voltage V_{BA} Measured phase-to-phase voltage V_{CB} Measured phase-to-phase voltage V_{AC} Calculated voltage V_0	
Method of measurement	Fundamental component RMS value	
Pickup value ¹⁰³	0.300 V to 340.000 V	increments of 0.001 V
Time delay	0.00 s to 60.00 s	increments of 0.01 s
Dropout ratio	0.90 to 0.99	increments of 0.01

Dropout

The greater dropout differential ($- | \text{pickup value} - \text{dropout value} |$) of the following 2 criteria applies:

Dropout differential derived from the parameter Dropout ratio	
If this parameter is not available, a dropout ratio of 95 % applies for the overvoltage and of 105 % for the undervoltage functionality.	
Minimum absolute dropout differential	150 mV sec.

Times

Operate time with time delay = 0 ms	Approx. 25 ms + OOT ¹⁰⁴ at 50 Hz Approx. 22 ms + OOT at 60 Hz
Dropout time	Approx. 20 ms + OOT

Frequency Operating Range

$0.9 \leq f/f_{rated} \leq 1.1$	According to specified tolerances
$10 \text{ Hz} \leq f < 0.9 f_{rated}$	Slightly expanded tolerances
$1.1 f_{rated} < f \leq 80 \text{ Hz}$	
$f < 10 \text{ Hz}$	Active
$f > 80 \text{ Hz}$	

Tolerances

Voltages	0.5 % of the setting value or 0.05 V
----------	--------------------------------------

¹⁰² If the function **Overvoltage protection with any voltage** is used in a 1-phase function group, the measured-value parameter is not visible.

¹⁰³ If you have selected the method of measurement – **RMS value**, do not set the threshold value under 10 V.

¹⁰⁴ OOT (Output Operating Time) additional delay of the output medium used, see Chapter 12.1.4 **Relay Outputs**

M. Reu

[Handwritten signature]

Time delays	1 % of the setting value or 10 ms
-------------	-----------------------------------

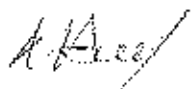
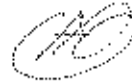

12.34 Peak Overvoltage Protection for Capacitors

Setting Values

Threshold value	0.80 to 3.00 p.u.	
Inverse-time stage	0.80 to 3.00 p.u.	Increments of 0.01
Definite-time stage	0.80 to 10.00 p.u.	Increments of 0.01
User-defined characteristic curve	0.80 to 3.00 p.u.	Increments of 0.01
Tripping delay	0.01 s to 3600.00 s	Increments of 0.01 s
Dropout delay	0.00 s to 3600.00 s	Increments of 1.00 s
Down integration time	1 min to 1500 min	Increments of 1 min
Time multiplier	0.05 to 15.00	Increments of 0.01
Number of value pairs for the operate curve	30	Increments of 1
X values of the operate curve	1.00 p.u. to 4.00 p.u.	Increments of 0.01 p.u.
Y values of the operate curve	0.00 s to 9999.99 s	Increments of 0.01 s
Number of value pairs for the dropout characteristic curve	30	Increments of 1
X values of the dropout characteristic curve	0.01 p.u. to 0.95 p.u.	Increments of 0.01 p.u.
Y values of the dropout characteristic curve	0.00 s to 9999.99 s	Increments of 0.01 s

Inverse-Time Characteristic Curve (IEC/IEEE)

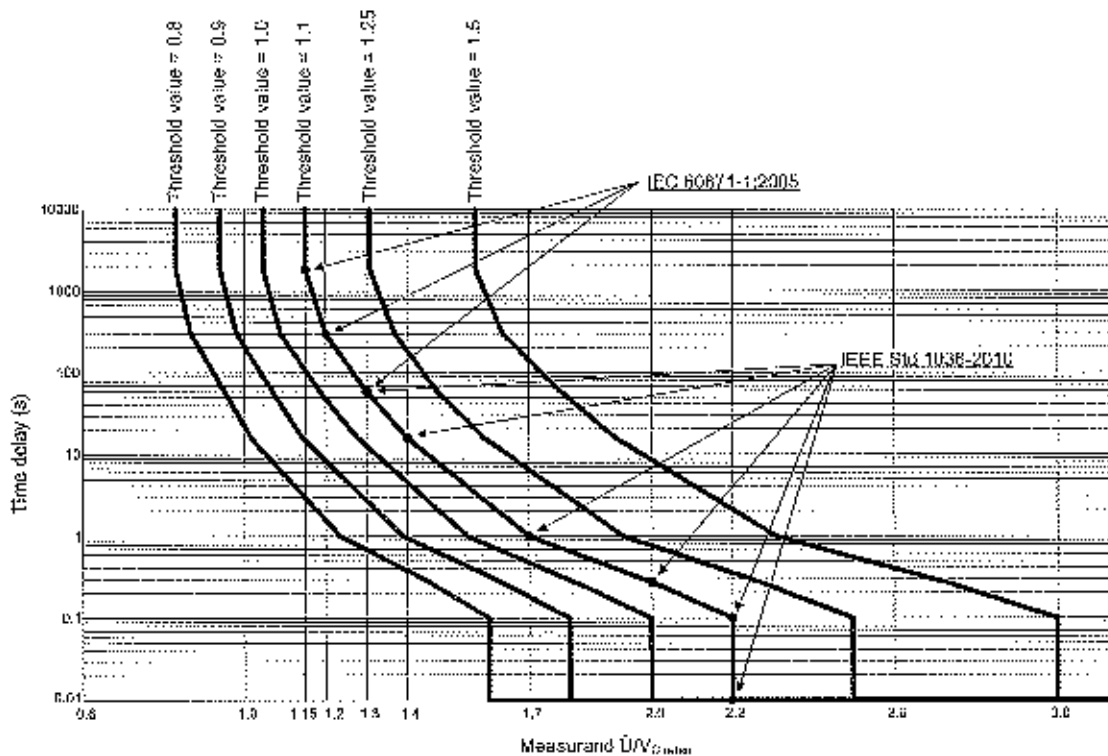

(3x point 230015, 2. en, CS)

Figure 12-18 Inverse Time Characteristic Curve

The points on the characteristic curve defined in the standards result from a threshold setting of 1.1. These single points are connected via semi-logarithmic line segments.

[Handwritten signature]

[Handwritten signature]

Table 12-5 Peak Overvoltage Inverse Time Characteristic (for Threshold Setting 1.1)

Measurand $\hat{U}/U_{c,rated}$	Time Delay	Curve Point According to
<1.15	∞ (no pickup)	Siemens definition
1.15	1800.00 s	IEC 60871-1:2005
1.2	300.00 s	IEC 60871-1:2005
1.3	60.00 s	IEC 60871-1:2005, IEEE Std 1036-2010
1.4	15.00 s	IEEE Std 1036-2010
1.7	1.00 s	IEEE Std 1036-2010
2	0.25 s	IEEE Std 1036-2010
2.2	0.1 s	IEEE Std 1036-2010
>2.2	0.01 s	IEEE Std 1036-2010

Times

Pickup time	Approx. 35 ms + OOT at 50 Hz ¹ Approx. 25 ms + OOT at 60 Hz ¹
Dropout Time	Depending on settings
¹ OOT (Output Operating Time) additional delay of the output medium used, for example, 5 ms with fast relays	

Frequency Operating Range

$0.9 \leq f/f_{rated} \leq 1.1$	According to specified tolerances
$10 \text{ Hz} \leq f < 0.9 f_{rated}$	Slightly expanded tolerances
$1.1 f_{rated} < f \leq 80 \text{ Hz}$	
$f < 10 \text{ Hz}$ $f > 80 \text{ Hz}$	Active

Tolerances

Peak overvoltage (33 % harmonics, with reference to fundamental component)	
Up to 30th harmonic	1 % of the setting value or 0.005 p.u. ($f_{rated} \pm 10\%$)
Up to 50th harmonic, $f_{rated} = 50 \text{ Hz}$	3 % of the setting value or 0.02 p.u. ($f_{rated} \pm 10\%$)
Up to 50th harmonic, $f_{rated} = 60 \text{ Hz}$	4 % of the setting value or 0.02 p.u. ($f_{rated} \pm 10\%$)
Time delays	
Measured value of inverse-time stage	5 % of the setting value + 1 % of the measured value or 30 ms
Measured value of definite-time stage	1 % of the setting value or 10 ms
Down integration time	5 % of the setting value or 30 ms

M. Puch

OP

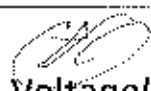

12.35 Overvoltage Protection with Negative-Sequence Voltage/Positive-Sequence Voltage

Setting Values for the Function

Measuring window	1 cycle to 10 cycles	Increments of 1 cycle
Minimum voltage V1	0.300 V to 60.000 V	increments of 0.001 V

Setting Values for Stage Types

Pickup value of $V2N\%$	0,50 % to 100,00 %	Increments of 0.01 %
Operate delay	0.00 s to 60.00 s	Increments of 0.01 s
Dropout ratio	0,90 to 0,99	Increments of 0,01

Dropout

The greater dropout differential (= | pickup value - dropout value |) of the following 2 criteria applies:

Dropout differential derived from the parameter Dropout ratio	
If this parameter is not available, a dropout ratio of 95 % applies for the overvoltage and of 105 % for the undervoltage functionality.	
Minimum absolute dropout differential	150 mV sec.

Times

Pickup times	55 ms to 210 ms + OOT ¹⁰⁰ (depends on the measuring-window length) at 50 Hz 48 ms to 190 ms + OOT (depends on the measuring-window length) at 60 Hz
Dropout times	22 ms to 55 ms + OOT (depends on the measuring-window length) at 50 Hz 18 ms to 45 ms + OOT (depends on the measuring-window length) at 60 Hz

Frequency Operating Range

$0,9 f_{rated}$ to $1,1 f_{rated}$	According to specified tolerances
10 Hz to $0,9 f_{rated}$	Slightly expanded tolerances
$1,1 f_{rated}$ to 80 Hz	
$f < 10$ Hz	Inactive
$f > 80$ Hz	

Tolerances

Vollages	0,50 % of the setting value or 0,050 V
Time delays	1,00 % of the setting value or 10 ms



¹⁰⁰ OOT (Output Operating Time) additional delay of the output medium used, for example 5 ms with fast relays

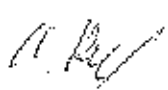

12.36 Undervoltage Protection with 3-Phase Voltage

Setting Values for Stage Type Definite Time-Undervoltage Protection

Measured value		Phase-to-phase Phase to-ground	
Method of measurement		Fundamental component RMS value	
Current-flow criterion		On Off	
Threshold value I>	1 A @ 50 and 100 Irated	0.030 A to 10.000 A	Increments of 0.001 A
	5 A @ 50 and 100 Irated	0.15 A to 50.00 A	increments of 0.01 A
	1 A @ 1.6 Irated	0.001 A to 1.600 A	Increments of 0.001 A
	5 A @ 1.6 Irated	0.005 A to 8.000 A	Increments of 0.001 A
Pickup value ¹⁰⁶		0.300 V to 175.000 V	Increments of 0.001 V
Time delay		0.00 s to 60.00 s	Increments of 0.01 s
Dropout ratio		1.01 to 1.20	Increments of 0.01

Setting Values for Stage Type Inverse Time-Undervoltage Protection

Measured value		Phase-to-phase Phase-to-ground	
Method of measurement		Fundamental component RMS value	
Current-flow criterion		On Off	
Threshold value I>	1 A @ 50 and 100 Irated	0.030 A to 10.000 A	increments of 0.001 A
	5 A @ 50 and 100 Irated	0.15 A to 50.00 A	Increments of 0.01 A
	1 A @ 1.6 Irated	0.001 A to 1.600 A	Increments of 0.001 A
	5 A @ 1.6 Irated	0.005 A to 8.000 A	Increments of 0.001 A
Threshold		0.300 V to 175.000 V	Increments of 0.001 V
Pickup factor		0.80 to 1.00	Increments of 0.01
Characteristic constant k		0.00 to 300.00	Increments of 0.01
Characteristic constant a		0.010 to 5.000	Increments of 0.001
Characteristic constant c		0.000 to 5.000	Increments of 0.001
Time multiplier		0.05 to 15.00	Increments of 0.01
Additional time delay		0.00 s to 60.00 s	Increments of 0.01 s
Reset time		0.00 s to 60.00 s	Increments of 0.01 s

Operate Curve

$$T_{op} = T_{inv} + T_{add}$$

Where:

T_{op} Operate delay

T_{inv} Inverse-time delay

T_{add} Additional time delay (parameter **Additional time delay**)

¹⁰⁶ If you have selected the method of measurement – RMS value, do not set the threshold value under 10 V.

$$T_{inv} = T_p \left(\frac{k}{1 - \left(\frac{V}{V_{thresh}} \right)^\alpha} + c \right) [s]$$

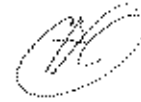

Fig. 12.36.3 (inverse, 2, on, 1.5)

Where

- T_{inv} Inverse-time delay
- T_p Time multiplier (parameter **Time dial**)
- V Measured undervoltage
- V_{thresh} Threshold value (parameter **Threshold**)
- k Curve constant k (parameter **Charact. constant k**)
- α Curve constant α (parameter **Charact. constant α**)
- c Curve constant c (parameter **Charact. constant c**)

Dropout

The greater dropout differential (= | pickup value - dropout value |) of the following 2 criteria applies:

Dropout differential derived from the parameter Dropout ratio	
If this parameter is not available, a dropout ratio of 95 % applies for the overvoltage and of 105 % for the undervoltage functionality.	
Minimum absolute dropout differential	150 mV sec.

Times

Pickup time	Approx. 25 ms + OOT ¹⁹⁷ at 50 Hz Approx. 22 ms + OOT at 60 Hz
Dropout time	Approx. 20 ms + OOT

Frequency Operating Range

$0.9 \leq f/f_{rated} \leq 1.1$	According to specified tolerances
$10 \text{ Hz} \leq f < 0.9 f_{rated}$	Slightly expanded tolerances
$1.1 f_{rated} < f \leq 80 \text{ Hz}$	
$f < 10 \text{ Hz}$ $f > 80 \text{ Hz}$	Inactive, maintained; Dropout of the pickup induced by blocking or by increasing the measurand beyond the dropout threshold

Tolerances for Stage Type Definite Time-Undervoltage Protection

Voltages	0.5 % of the setting value or 0.05 V
Currents	1 % of the setting value or 5 mA ($I_{rated} = 1 \text{ A}$) or 25 mA ($I_{rated} = 5 \text{ A}$, $f_{rated} \pm 10 \%$), valid for protection-class current transformers
	1 % of the setting value or 0.1 mA ($I_{rated} = 1.6 \text{ A}$) or 0.5 mA ($I_{rated} = 8 \text{ A}$, $f_{rated} \pm 10 \%$), valid for instrument transformers
Time delays	1 % of the setting value or 10 ms

¹⁹⁷ OOT (Output Operating Time) additional delay of the output medium used, see Chapter 12.1.4 Relay Outputs

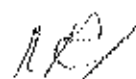

Tolerances for Stage Type Inverse Time-Undervoltage Protection

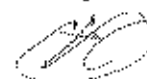

Voltages	0.5 % of the setting value or 0.05 V
Currents	1 % of the setting value or 5 mA ($I_{rated} = 1$ A) or 25 mA ($I_{rated} = 5$ A, $f_{rated} \pm 10$ %), valid for protection-class current transformers
	1 % of the setting value or 0.1 mA ($I_{rated} = 1.6$ A) or 0.5 mA ($I_{rated} = 8$ A, $f_{rated} \pm 10$ %), valid for instrument transformers
Operate time for $0 < V/V_{inresh} < 0.9$	5 % of the setting value or 30 ms
Reset time delay	1 % of the setting value or 10 ms

12.37 Undervoltage Protection with Positive-Sequence Voltage

Setting Values

Measured value	Phase-to-phase Phase-to-ground		
Method of measurement	Fundamental component RMS value		
Current-flow criterion	On Off		
Threshold value I ₀	1 A @ 50 and 100 Irated	0.030 A to 10.000 A	Increments of 0.001 A
	5 A @ 50 and 100 Irated	0.15 A to 50.00 A	Increments of 0.01 A
	1 A @ 1.6 Irated	0.001 A to 1.600 A	Increments of 0.001 A
	5 A @ 1.6 Irated	0.005 A to 8.000 A	Increments of 0.001 A
Pickup value	0.300 V to 175.000 V		Increments of 0.001 V
Time delay	0.00 s to 60.00 s		Increments of 0.01 s
Dropout ratio	1.01 to 1.20		Increments of 0.01

Dropout

The greater dropout differential (= | pickup value - dropout value |) of the following 2 criteria applies:

Dropout differential derived from the parameter Dropout ratio	
If this parameter is not available, a dropout ratio of 95 % applies for the overvoltage and of 105 % for the undervoltage functionality.	
Minimum absolute dropout differential	150 mV sec.

Times

Operate time	Approx. 25 ms + OOT ¹⁰⁹ at 50 Hz Approx. 22 ms + OOT at 60 Hz
Dropout time	Approx. 20 ms + OOT

Frequency Operating Range

$0.9 \leq f/f_{rated} \leq 1.1$	According to specified tolerances
$10 \text{ Hz} \leq f < 0.9 f_{rated}$	Slightly expanded tolerances
$1.1 f_{rated} < f \leq 80 \text{ Hz}$	
$f < 10 \text{ Hz}$	Inactive, maintained;
$f > 80 \text{ Hz}$	Dropout of the pickup induced by blocking or by increasing the measurand beyond the dropout threshold

Tolerances

Voltages	0.5 % of the setting value or 0.05 V
----------	--------------------------------------

¹⁰⁹ OOT (Output Operating Time) additional delay of the output medium used, see Chapter 1.2.1.4 Relay Outputs

M. Red

OK

Currents	1 % of the setting value or 5 mA ($I_{\text{rated}} = 1 \text{ A}$) or 25 mA ($I_{\text{rated}} = 5 \text{ A}$, $f_{\text{rated}} \pm 10 \%$), valid for protection-class current transformers
	1 % of the setting value or 0.1 mA ($I_{\text{rated}} = 1.6 \text{ A}$) or 0.5 mA ($I_{\text{rated}} = 8 \text{ A}$, $f_{\text{rated}} \pm 10 \%$), valid for instrument transformers
Time delays	1 % of the setting value or 10 ms

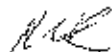

12.38 Undervoltage Protection with Any Voltage

Setting Values

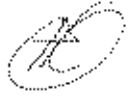
Measured value	Measured phase-to-ground voltage V_A Measured phase-to-ground voltage V_B Measured phase-to-ground voltage V_C Measured phase-to-phase voltage V_{AB} Measured phase-to-phase voltage V_{BC} Measured phase-to-phase voltage V_{CA} Calculated phase-to-phase voltage V_{AB} Calculated phase-to-phase voltage V_{BC} Calculated phase-to-phase voltage V_{CA} Calculated voltage V_0	
Method of measurement	Fundamental component RMS value	
Pickup value ¹¹⁹⁾	0.300 V to 340.000 V	Increments of 0.003 V
Time delay	0.00 s to 60.00 s	Increments of 0.01 s
Dropout ratio	1.01 to 1.20	Increments of 0.01

Dropout

The greater dropout differential (= { **pickup value** - **dropout value** }) of the following 2 criteria applies:

Dropout differential derived from the parameter Dropout ratio If this parameter is not available, a dropout ratio of 95 % applies for the overvoltage and of 105 % for the undervoltage functionality.	
Minimum absolute dropout differential	±50 mV sec.

Times

Operate time with time delay – 0 ms	Approx. 25 ms + OOT ¹¹⁹⁾ at 50 Hz Approx. 22 ms + OOT at 60 Hz
Dropout time	Approx. 20 ms + OOT

Frequency Operating Range

$0.9 \leq f/f_{\text{rated}} \leq 1.1$	According to specified tolerances
$10 \text{ Hz} \leq f < 0.9 f_{\text{rated}}$ $1.1 f_{\text{rated}} < f \leq 80 \text{ Hz}$	Slightly expanded tolerances
$f < 10 \text{ Hz}$ $f > 80 \text{ Hz}$	Inactive, maintained; Dropout of the pickup induced by blocking or by increasing the measurand beyond the dropout threshold

Tolerances

Voltages	0.5 % of the setting value or 0.05 V
Time delays	1 % of the setting value or 10 ms

¹¹⁹⁾ If you have selected the **method of measurement** = **RMS value**, do not set the threshold value under 10 V.

¹¹⁸⁾ OOT (Output Operating Time) additional delay of the output medium used, see chapter 12.1.4 *Binary Outputs*

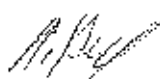

12.39 Overfrequency Protection

Setting Values

Pickup values f_p	40.00 Hz to 70.00 Hz	Increments of 0.01 Hz
Dropout differential	20 mHz to 2 000 mHz	Increments of 10 mHz
Time delay T	0.00 s to 600.00 s	Increments of 0.01 s
Minimum voltage	3.000 V to 175.000 V	Increments of 0.001 V

Times

Pickup times t_p	Angle difference method	
	50 Hz	Approx. 70 ms + OOT ¹⁾
	60 Hz	Approx. 60 ms + OOT
	Filtering method	
Dropout times t_d	50 Hz	Approx. 75 ms + OOT
	60 Hz	Approx. 75 ms + OOT
Dropout times t_d		60 ms to 80 ms

Dropout

The larger dropout differential (= | pickup value - dropout threshold |) of the following 2 criteria is used:

Dropout differential derived from the Dropout ratio parameter	
If this parameter is not available, a dropout ratio of 95 % applies to the overvoltage protection and a dropout ratio of 105 % applies to the undervoltage protection.	
Minimum absolute dropout differential	150 mV sec.

Operating Ranges

Voltage range	5 V to 230 V (phase-phase)	
Frequency range	Angle difference method	50 Hz to 80 Hz
	Filtering method	25 Hz to 80 Hz

Tolerances

Frequency f_p	
$f_{rated} - 0.20 \text{ Hz} < f < f_{rated} + 0.20 \text{ Hz}$	$\pm 5 \text{ mHz}$ at $V = V_{rated}$
$f_{rated} - 3.0 \text{ Hz} < f < f_{rated} + 3.0 \text{ Hz}$	$\pm 10 \text{ mHz}$ at $V = V_{rated}$
Time delay T(f_p)	1 % of the setting value or 10 ms
Minimum voltage	1 % of the setting value or 0.5 V

¹⁾ OOT (Output Operating Time) Additional delay of the output medium used, for example 5 ms with fast relay, see chapter 12.1.4 Relay Outputs

12.40 Underfrequency Protection

Setting Values

Pickup values $f<$	40.00 Hz to 70.00 Hz	Increments of 0.01 Hz
Dropout differential	20 mHz to 7 000 mHz	Increments of 10 mHz
Time delay T	0.00 s to 600.00 s	Increments of 0.01 s
Minimum voltage	3.000 V to 175.000 V	Increments of 0.001 V

Times

Pickup times $f<$	Angle difference method	
	50 Hz	Approx. 70 ms + OOT ^{1,2}
	60 Hz	Approx. 60 ms + OOT
	Filtering method	
50 Hz	Approx. 75 ms + OOT	
	60 Hz	Approx. 75 ms + OOT
Dropout times $f<$	60 ms to 80 ms	

Dropout

The larger dropout differential ($- | \text{pickup value} - \text{dropout threshold} |$) of the following two criteria is used:

Dropout differential derived from the Dropout ratio parameter	
If this parameter is not available, a dropout ratio of 95 % applies to the overvoltage protection and a dropout ratio of 105 % applies to the undervoltage protection.	
Minimum absolute dropout differential	150 mV sec.

Operating Ranges

Voltage range	5 V to 230 V (phase-phase)	
Frequency range	Angle difference method	10 Hz to 80 Hz
	Filtering method	25 Hz to 80 Hz

Tolerances

Frequency $f<$	
$f_{\text{rated}} - 0.20 \text{ Hz} < f < f_{\text{rated}} + 0.20 \text{ Hz}$	$\pm 5 \text{ mHz}$ at $V = V_{\text{rated}}$
$f_{\text{rated}} - 3.0 \text{ Hz} < f < f_{\text{rated}} + 3.0 \text{ Hz}$	$\pm 10 \text{ mHz}$ at $V = V_{\text{rated}}$
Time delay $T(f<)$	1 % of the setting value or 10 ms
Minimum voltage	1 % of the setting value or 0.5 V

^{1,2} OOT (Output Operating Time) Additional delay of the output medium used, for example 5 ms with fast relay, see chapter 12.1.4 Relay Output

A. R. ...

...

12.41 Rate of Frequency Change Protection

Setting Values for the Function

Minimum voltage	3.000 V to 175.000 V	Increments of 0.001 V
Measuring window	2 periods to 5 periods	Increments of 1 period

Setting Values for Stage Types

Threshold	0.1 Hz/s to 20.0 Hz/s	Increments of 0.1 Hz/s
Dropout differential	0.02 Hz/s to 0.99 Hz/s	Increments of 0.01 Hz/s
Operate delay	0.00 s to 60.00 s	Increments of 0.01 s

Dropout

The greater dropout differential ($\sim | \text{pickup value} - \text{dropout value} |$) of the following 2 criteria applies:

Dropout differential derived from the parameter Dropout ratio If this parameter is not available, a dropout ratio of 95 % applies for the overvoltage and of 105 % for the undervoltage functionality.	
Minimum absolute dropout differential	150 mV sec.

Times

Pickup time	Approx. 165 ms to 225 ms (depends on measuring window length)
Dropout time	Approx. 165 ms to 225 ms (depends on measuring window length)

Frequency Operating Range

$0.9 < f/f_{\text{rated}} < 1.1$	According to specified tolerances
$10 \text{ Hz} \leq f < 0.9 f_{\text{rated}}$ $1.1 f_{\text{rated}} < f \leq 80 \text{ Hz}$	Slightly expanded tolerances
$f < 10 \text{ Hz}$ $f > 80 \text{ Hz}$	inactive

Tolerances

Threshold, measuring window > 3 periods	Approx. 3 % or 0.06 Hz/s
Threshold, measuring window ≤ 3 periods	Approx. 5 % or 0.06 Hz/s
Minimum voltage	\pm % of the setting value or 0.5 V
Time delays	1 % of the setting value or 10 ms

Functional Measured Value

Value	Description
dfdt	Calculated rate of frequency change

12.42 3-Phase Power Protection (P,Q)

Setting Values

Measured value	Positive sequence power Power of phase A Power of phase B Power of phase C	
Threshold value	-200.0 % to +200.0 %	increments of 0.1
Tilt-power characteristic	-89.0° to +89.0°	increments of 0.1°
Dropout delay time	0.00 s to 60.00 s	increments of 0.01 s
Time delay	0.00 s to 60.00 s	increments of 0.01 s
Dropout ratio	Upper stage: 0.90 to 0.99 Lower stage: 1.01 to 1.10	increments of 0.01 increments of 0.01

Times

Pickup times	Approx. 55 ms + OOT ¹⁾²⁾ at 50 Hz Approx. 45 ms + OOT at 60 Hz
Dropout times	Approx. 55 ms + OOT at 50-Hz Approx. 45 ms + OOT at 60 Hz

Tolerances

Power	0.5 % S_{rated} + 3 % of setting value (S_{rated} : rated apparent power)
Time delays	1 % of the setting value or 10 ms

Variables That Influence Pickup Values

Auxiliary DC voltage in the range $0.8 \leq V_{\text{Aux}}/V_{\text{AuxRated}} \leq 1.15$	± 1 %
Frequency in the range $0.95 \leq f/f_{\text{rated}} \leq 1.05$	± 1 %
Harmonics	± 1 %
- Up to 10 % of 3rd harmonics	± 1 %
- Up to 10 % of 5th harmonics	± 1 %

¹⁾²⁾OOT (Output Operating Time) additional delay of the output medium used, see Chapter 12.1.4 Relay Outputs

12.43 Reverse-Power Protection

Setting Values

Reverse power P_{reverse} (p.u.)	-0.30 % to -30.00 %	Increments of 0.01 %
Angle correction	-10.00 ° to 10.00 °	Increments of 0.01 °
Minimum voltage V1	0.300 V to 60.000 V	Increments of 0.001 V
Tripping delay	0.00 s to 60.00 s	0.00 s to 60.00 s
Tripping delay with quick stop	0.00 s to 60.00 s	0.00 s to 60.00 s
Dropout delay	0.00 s to 60.00 s	Increments of 0.01 s
Dropout ratio	0.40 to 0.99	Increments of 0.01

Times

Pickup times	Approx. 360 ms at $f = 50$ Hz Approx. 300 ms at $f = 60$ Hz
Dropout times	Approx. 360 ms at $f = 50$ Hz Approx. 300 ms at $f = 60$ Hz

Frequency Operating Range

$0.9 \leq f/f_{\text{rated}} \leq 1.1$	According to specified tolerances
$10 \text{ Hz} \leq f < 0.9 f_{\text{rated}}$ $1.1 f_{\text{rated}} < f \leq 80 \text{ Hz}$	Slightly expanded tolerances
$f < 10 \text{ Hz}$ $f > 80 \text{ Hz}$	Inactive

Tolerances

Reverse power	0.15 % S_{rated} or 5 % of the setting value when $Q < 0.5 S_{\text{rated}}$
Time delays	1 % or 10 ms

12.44 Overexcitation Protection

Setting Values

Threshold value (characteristic curve dependent on pickup)	$\frac{U_{U_{nom}}}{f_{f_{nom}}}$	1.00 to 1.20	Increments of 0.01
Threshold value (characteristic curve independent on pickup)	$\frac{U_{U_{nom}}}{f_{f_{nom}}}$	1.00 to 1.40	Increments of 0.01
Time delay (warning delay and tripping delay)		0.00 s to 60.00 s	Increments of 0.01 s
Characteristic value pairs		2 to 30	
	Value ranges	V/f	1.00 p.u. to 10.00 p.u.
		t	0 s to 100 000 s
Cooling time therm. replica			0 s to 100 000 s

Functional Measured Values

Measured Value	Description
(_:2311:322) V/f	Value calculated from voltage and frequency.
(_:13501) Therm. charact.	Thermal tripping of the overexcitation protection. If the value reaches 100 %, tripping occurs.

Frequency Operating Range

$0.9 \leq f_{rated} \leq 1.1$	According to specified tolerances
$10 \text{ Hz} \leq f < 0.9 f_{rated}$	Slightly expanded tolerances
$1.1 f_{rated} < f < 80 \text{ Hz}$	
$f < 10 \text{ Hz}$ $f > 80 \text{ Hz}$	Active

Operating Times

Operate times/dropout times		
Operate time at frequency	50 Hz	60 Hz
Minimum	33 ms + OOT ¹⁴	30 ms + OOT ¹⁴
Dropout time	10 ms + OOT ¹⁴	10 ms + OOT ¹⁴

Dropout Ratios

Warning, tripping (independent stage)	Approx. 0.98
---------------------------------------	--------------

Operate Curve

Thermal replica	For default setting refer to the following characteristic curve <i>Figure 12-19</i>
-----------------	---

Tolerances

V/f pickup	2 % of the setting value
Time delays	1 % of the setting value or 10 ms (min. 1.5 periods)
Thermal replica	5 % based on $V/f \pm 600 \text{ ms}$

¹⁴ Refer to protection functions, for example overcurrent protection

A. B...

Voltage measurement accuracy	0.5 % of the setting value or 0.5 V in the range $f_n \pm 10\%$
Frequency measurement accuracy	1.0 % of the setting value or 1.0 Hz in the frequency range 10 Hz to 80 Hz

Influencing Quantities

Auxiliary direct voltage in the 0.8 range	$\leq 1\%$
Time delays	$\leq 0.5\%/10\text{ K}$
Thermal replica	$\leq 1\%$
Harmonics	
Up to 10 % of 3rd harmonic	$\leq 1\%$
Up to 10 % of 5th harmonic	$\leq 1\%$

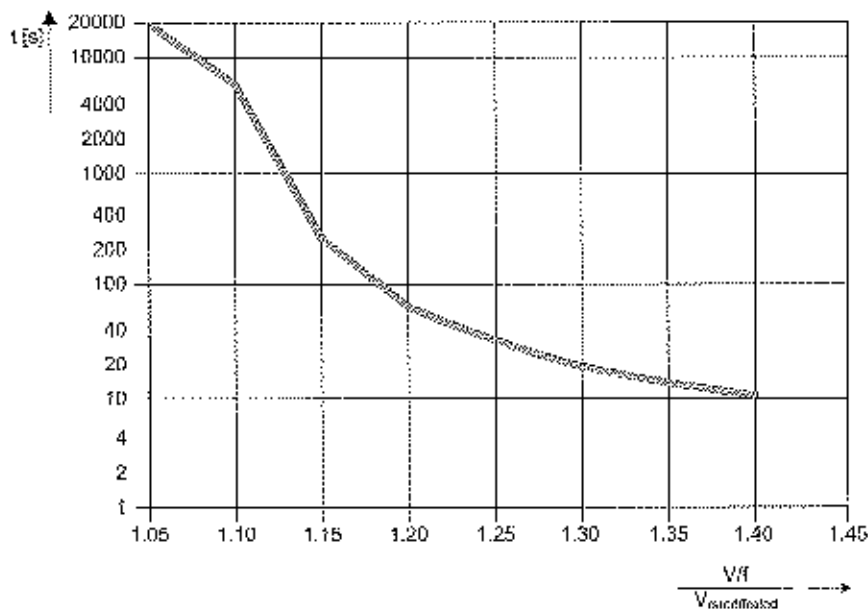

[060550-07/13-01 (v. 1.0) (11)]

Figure 12-19 Operate Curve from the Thermal Replica of the Overexcitation Protection (Default Setting)

12.45 Undervoltage-Controlled Reactive-Power Protection

Setting Values

Threshold value	Power Q	1.00 % to 200.00 %	Increments of 0.01 %
	Voltage of protection stage	3.000 to 175.000	Increments of 0.001 V
	Voltage of reclosure stage	3.000 V to 340.000 V	Increments of 0.001 V
Current I_{r} release threshold	1 A @ 50 and 100 Irated	0.030 A to 10.000 A	increments of 0.001 A
	5 A @ 50 and 100 Irated	0.15 A to 50.00 A	increments of 0.01 A
	1 A @ 1.6 Irated	0.001 A to 1.600 A	increments of 0.001 A
	5 A @ 1.6 Irated	0.005 A to 8.000 A	increments of 0.001 A
Operate delay		0.00 s to 60.00 s	increments of 0.01 s
Release time delay of reclosure stage		0.00 s to 3600.00 s	increments of 0.01 s

Dropout Ratio

Protection stage	
Reactive power flow Q	Approx. 0.95
Voltage	Approx. 1.05
Release current	Approx. 0.95
Reclosure stage	
Voltage	Approx. 0.95
Release current	Approx. 0.95

Times

Pickup time	Approx. 55 ms + 0.0T ^{1.1} at 50 Hz Approx. 45 ms + 0.0T at 60 Hz
Dropout time	Approx. 55 ms + 0.0T at 50 Hz Approx. 45 ms + 0.0T at 60 Hz

Tolerances

Current I_{r}	1 % of the setting value or 5 mA ($I_{\text{rated}} = 1 \text{ A}$) or 25 mA ($I_{\text{rated}} = 5 \text{ A}$)
Voltage	0.5 % of the setting value or 0.05 V
Power Q	0.5 % $S_{\text{rated}} \pm 3 \%$ of the setting value (S_{rated} : rated apparent power)
Time delays	1 % of the setting value or 10 ms
Reclosure time delay	1 % of the setting value or 10 ms

Frequency Operating Range

$0.9 \leq f/f_{\text{rated}} \leq 1.1$	According to specified tolerances
$10 \text{ Hz} \leq f < 0.9 f_{\text{rated}}$	Slightly expanded tolerances
$1.1 f_{\text{rated}} < f \leq 80 \text{ Hz}$	

¹⁾ GOT (Output Operating Time) additional delay of the output medium used, for example 5 ms with fast relays

$f < 10 \text{ Hz}$ $f > 80 \text{ Hz}$	Active
--	--------



12.46 Circuit-Breaker Failure Protection

Starting Conditions

For circuit-breaker failure protection	3-pole tripping internal or external ¹⁾⁶
--	---

Setting Values

Phase-current threshold values	1 A @ 100 I _{rated}	0.030 A to 35.000 A	Increments of 0.001 A
	1 A @ 50 I _{rated}		
	5 A @ 100 I _{rated}	0.15 A to 175.00 A	Increments of 0.01 A
	5 A @ 50 I _{rated}		
Sensitive threshold value	1 A @ 1.6 I _{rated}	0.001 A to 1.600 A	Increments of 0.001 A
	5 A @ 1.6 I _{rated}	0.005 A to 8.000 A	Increments of 0.001 A
	1 A @ 100 I _{rated}	0.030 A to 35.000 A	Increments of 0.001 A
	1 A @ 50 I _{rated}		
	5 A @ 100 I _{rated}	0.15 A to 175.00A	Increments of 0.01 A
	5 A @ 50 I _{rated}		
1 A @ 1.6 I _{rated}	0.001 A to 1.600 A	Increments of 0.001 A	
5 A @ 1.6 I _{rated}	0.005 A to 8.000 A	Increments of 0.001 A	
Supervision time of release signal		0.06 s to 1.00 s	Increments of 0.01 s
Time delays		0.05 s to 60.00 s	Increments of 0.001 s
Supervision time of binary inputs		0.05 s to 60.00 s	Increments of 0.01 s

Dropout

The greater dropout differential (= | pickup value - dropout value |) of the following 2 criteria applies:

Dropout differential derived from the parameter Dropout ratio	
If this parameter is not available, a dropout ratio of 95 % applies for overcurrent and of 105 % for undercurrent functionality.	
Minimum absolute dropout differential	
Protection-class current transformer	15 mA sec. (I _{rated} = 1 A) or 75 mA sec. (I _{rated} = 5 A)
Instrument current transformer	0.5 mA sec. (I _{rated} = 1 A) or 2.5 mA sec. (I _{rated} = 5 A)

Circuit-Breaker Supervision

Position supervision via circuit-breaker auxiliary contacts	
For 3-pole CB tripping	1 input each for make contact and break contact



NOTE

The circuit-breaker failure protection can also work without the circuit breaker auxiliary contacts stated. Auxiliary contacts are required for circuit-breaker failure protection in cases where the current flow is absent or too low for tripping (for example with a transformer or a Buchholz protection).

¹⁾⁶Via binary inputs

Times

Pickup time, in the case of an internal start	< 1 ms
Pickup time, in the case of an external start	< 5 ms
Typical dropout time	< 15 ms
Dropout time via circuit-breaker auxiliary-contact criterion	< 5 ms

Frequency Operating Range

$0.9 \leq f/f_{\text{rated}} \leq 1.1$	According to specified tolerances
$10 \text{ Hz} \leq f < 0.9 f_{\text{rated}}$ $1.1 f_{\text{rated}} < f \leq 80 \text{ Hz}$	Slightly expanded tolerances
$f < 10 \text{ Hz}$ $f > 80 \text{ Hz}$	Active

Tolerances

Threshold values, dropout thresholds	2 % of the setting value or 1 % of the rated current
Times	1 % of the setting value or 10 ms

12.47 Circuit-Breaker Restrike Protection

Setting Values

Threshold value	3 A @ 50 and 100 I _{rated}	0.030 A to 35.000 A	Increments of 0.001 A
	5 A @ 50 and 100 I _{rated}	0.15 A to 175.00 A	Increments of 0.01 A
	1 A @ 1.6 I _{rated}	0.001 A to 1.600 A	Increments of 0.001 A
	5 A @ 1.6 I _{rated}	0.005 A to 8.000 A	Increments of 0.001 A
Monitoring duration		1.00 s to 600.00 s	Increments of 0.01 s
Position recognition delay		0.00 s to 60.00 s	Increments of 0.01 s
Dropout delay		0.00 s to 60.00 s	Increments of 0.01 s
Trip delay time		0.05 s to 60.00 s	Increments of 0.01 s
Retrip delay time		0.00 s to 60.00 s	Increments of 0.01 s
Minimum operate (trip) time		0.00 s to 60.00 s	Increments of 0.01 s

Dropout

The greater dropout differential ($=$ pickup value $-$ dropout value) of the following 2 criteria applies:

Dropout differential derived from the parameter Dropout ratio	
If this parameter is not available, a dropout ratio of 95 % applies for overcurrent and of 105 % for undercurrent functionality.	
Minimum absolute dropout differential	
Protection-class current transformer	15 mA sec. (I _{rated} = 1 A) or 75 mA sec. (I _{rated} = 5 A)
Instrument current transformer	0.5 mA sec. (I _{rated} = 1 A) or 2.5 mA sec. (I _{rated} = 5 A)

Times

Operate time with time delay = 0 ms	Approx. 25 ms + OOT at 50 Hz Approx. 22 ms + OOT at 60 Hz
Dropout time	Approx. 20 ms + OOT

Frequency Operating Range

$0.9 < f/f_{rated} \leq 1.1$	According to specified tolerances
$10 \text{ Hz} \leq f < 0.9 f_{rated}$	Slightly expanded tolerances
$1.3 f_{rated} < f \leq 80 \text{ Hz}$	
$f < 10 \text{ Hz}$ $f > 80 \text{ Hz}$	Active

Tolerances

Threshold	1 % of the setting value or 5 mA (I _{rated} = 1 A) or 25 mA (I _{rated} = 5 A)
Time delays	1 % of the setting value or 10 ms

12.48 Restricted Ground-Fault Protection

Setting Values

Threshold value ¹⁷	0.05 A to 2.00 A	Increments of 0.05 A
Gradient	0.00 to 0.95	Increments of 0.01
Operate curve	See figure	
Pickup tolerance (for preset characteristic curve parameters; for 2 sides with 1 measuring point each)	2 %	
Tripping delay	0.00 s to 60.00 s or ∞ (no tripping)	Increments of 0.01 s
Timer tolerance	1 % of the setting value or 10 ms	

Functional Measured Values

Measured Value	Description
(_:306) I REF, operate	Operate quantity of the restricted ground-fault protection from the angle criterion
(_:307) I Angle, REF	Stabilizing value (angle) of the restricted ground-fault protection from the angle criterion
(_:311) I REF, Trip operate	Operate quantity of the restricted ground-fault protection when OFF
(_:312) I angle, REF operate	Stabilizing value of the restricted ground-fault protection when OFF
(_:303) I diff.	Differential current
(_:302) I restr.	Restrains current

Dropout Ratio

Threshold value	0.7
-----------------	-----

Dropout

The greater dropout differential (= | pickup value - dropout value |) of the following 2 criteria applies:

Dropout differential derived from the parameter Dropout ratio	
If this parameter is not available, a dropout ratio of 95 % applies for overcurrent and of 105 % for undercurrent functionality.	
Minimum absolute dropout differential	
Protection-class current transformer	15 mA sec. (I _{rated} = 1 A) or 75 mA sec. (I _{rated} = 5 A)
Instrument current transformer	0.5 mA sec. (I _{rated} = 1 A) or 2.5 mA sec. (I _{rated} = 5 A)

Times

7UT82/7UT85/7UT86/7UT87		
Frequency	50 Hz	60 Hz
	Operate time	Operate time

¹⁷The specified setting limit can be dynamically further limited, depending on the transformer adaptation factor, (for this refer to Chapter 6.4.4 Application and Setting Times).

At 1.5 · setting value threshold value	33 ms + OOT	32 ms + OOT
At 2.5 · setting value threshold value	27 ms + OOT	26 ms + OOT
Dropout time approx.	80 ms	67 ms

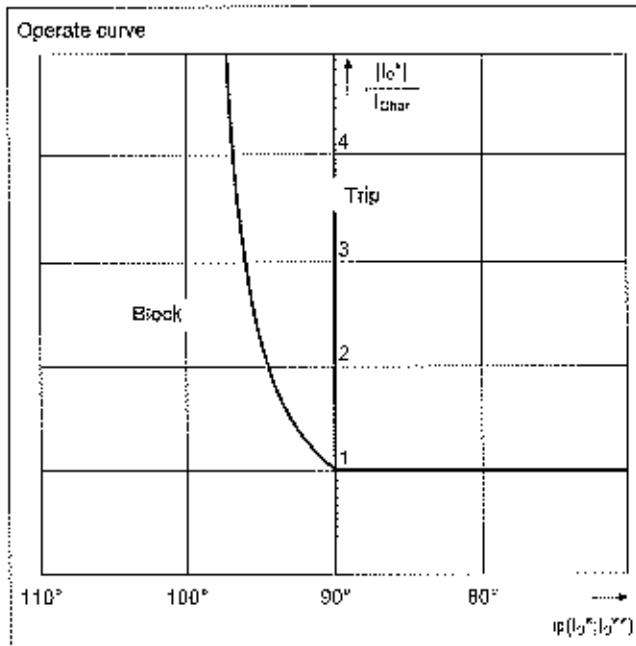

AC

Siemens 120712 01.05.16 en_US

Figure 12-20 Restricted Ground-Fault Protection Operate Curve depending on the Phase Angle between I_a^* and I_b^{**} at $|I_a^*| = |I_b^{**}|$ (180° ~ External fault)

M

Ar De...

12.49 External Trip Initiation

Setting Values

Tripping delay	0.00 s to 60.00 s	Increments of 0.01 s
----------------	-------------------	----------------------

Times

Operate time with time delay = 0 ms - At initiation via binary input signal	Approx. 10 ms + OOT ¹¹⁸
--	------------------------------------

Tolerance

Sequence tolerance for delay times	1 % of the setting value or 10 ms
------------------------------------	-----------------------------------

¹¹⁸ OOT (Output Operating Time) additional delay of the output medium used, for example 5 ms with fast relays, see chapter 12.1.4 Relay Outputs

12.50 Automatic Reclosing

Function specifications	Cyclic automatic reclosing function Automatic reclosing function with adaptive dead time (ADT) Operation with External Automatic Reclosing Function	
Number of reclosings	Max. 8, per individual settings	
Type (depending on the order variation)	1-pole, 3-pole, or 1-/3-pole	
Operating mode of the automatic reclosing function	With trip command, without action time With trip command, with action time With pickup, without action time With pickup, with action time	
Reclaim time after reclosing	0.50 s to 300.00 s	Increments of 0.01 s
Blocking time after dynamic blocking	0.5 s	-
Blocking time after manual closure	0.00 s to 300.00 s	Increments of 0.01 s
Start supervision time	0.01 s to 300.00 s	Increments of 0.01 s
Circuit-breaker supervision time	0.01 s to 300.00 s	Increments of 0.01 s
Evolving-fault detection	With trip command with Pickup	
Reaction to evolving faults	Blocks automatic reclosing function Start, evolving fault, dead time	
Action times (separated for all cycles)	0.00 s to 300.00 s or ∞ (ineffective)	Increments of 0.01 s
Dead times after trip command (separated for all types and all cycles)	0.00 s to 1 800.00 s or ∞ (ineffective)	Increments of 0.01 s
Dead time after evolving-fault detection (separated for all cycles)	0.00 s to 1 800.00 s	Increments of 0.01 s
Synchrocheck after 3-pole dead time	None Internal External	
Transmission delay, inter close command	0.00 s to 300.00 s or ∞ (ineffective)	Increments of 0.01 s
Dead line check/reduced dead time	Without Reduced dead time (VWE) Dead line checking	
Voltage supervision warning time	0.10 s to 30.00 s	Increments of 0.01 s
Limiting value for fault-free line	0.3 V to 340.0 V	Increments of 0.1 V
Limiting value for zero potential	0.3 V to 340.0 V	Increments of 0.1 V

12.51 Fault Locator

Setting Values

Reactance per unit length of the line per kilometer or per mile	
Line length for the correct output of the fault distance as a percentage of the line length	
The residual compensation factors in the setting format K _r and K _x or K ₀ and angle (K ₀)	
Consideration of the load current for 1-pole ground faults	Correction of the X value, for connection and disconnection

Fault Distance

Output of the fault distance (line length)	In Ω primary and secondary In km, miles or in percent. ¹¹⁹
--	--

Tolerances

Measuring tolerances during sinusoidal measurands and error duration > 25 ms at 60 Hz or > 30 ms at 50 Hz	1.5 % from fault location at $V_{kN_{(250)}} \geq 0.01$ and one of the following scenarios: <ul style="list-style-type: none"> • Metal fault • Non-metallic fault for one-side infeed without load
---	--

¹¹⁹ The output of the fault distance in km, miles and percent presupposes a homogenous line.

12.52 Temperature Supervision

Setting Values

Pickup value	-50 °C to 250 °C 58 °F to 482 °F	Increments of 1°C Increments of 1°F
Time delay	0 s to 60 s or ∞	Increments of 1 s

Dropout Conditions

Dropout differential	3 °C or 6 °F
----------------------	--------------

Tolerances

Tripping delay	±1 % of the setting value or ±10 ms
Measured temperature value	±0.5 % of the setting value or ±1 °C or ±2 °F

12.53 Current-Jump Detection

Times

Pickup time	Approx. 10 ms + OOT ¹²⁹ at 50 Hz Approx. 8 ms + OOT at 60 Hz
-------------	--

Frequency Operating Range

$0.9 \leq f/f_{rated} \leq 1.1$	According to specified tolerances
$10 \text{ Hz} \leq f < 0.9 f_{rated}$ $1.1 f_{rated} < f \leq 80 \text{ Hz}$	Slightly expanded tolerances
$f < 10 \text{ Hz}$ $f > 80 \text{ Hz}$	Inactive

Tolerances

Currents	3 % of setting value or 10 mA ($I_{rated} = 1 \text{ A}$) or 50 mA ($I_{rated} = 5 \text{ A}$), ($f_{rated} \pm 10 \%$) for amplitude changes of sinusoidal measurands
Pulse time	1 % of the setting value or 10 ms

¹²⁹ OOT (Output Operating Time) additional delay of the output medium used, for example 5 ms with fast relays

H. Reed

12.54 Voltage-Jump Detection

Times

Pickup time	Approx. 10 ms + OOT ¹²¹ at 50 Hz Approx. 8 ms + OOT at 60 Hz
-------------	--

Frequency Operating Range

$0.9 \leq f/f_{rated} \leq 1.1$	According to specified tolerances
$10 \text{ Hz} \leq f < 0.9 f_{rated}$	Slightly expanded tolerances
$1.1 f_{rated} < f \leq 80 \text{ Hz}$	
$f < 10 \text{ Hz}$ $f > 80 \text{ Hz}$	Inactive

Tolerances

Voltages	2 % of the setting value or 0.100 V for amplitude changes of sinusoidal measurands
Pulse time	1 % of the setting value or 10 ms

¹²¹ OOT (Output Operating Time) additional delay of the output medium used, for example 5 ms with fast relays

Ac Real

[Handwritten signature]

12.55 Synchronization Function

Operating Modes

Synchrocheck
Switching synchronous systems
Switching asynchronous systems
De-energized switching
Direct closing command

Setting Values

Supervision/Delay times:		
Max. Duration of synchronization process	0.00 s to 3 600.00 s or ∞ (ineffective)	Increments of 0.01 s
Supervision time de-energized switching	0.00 s to 60.00 s	Increments of 0.01 s
Closure delay	0.00 s to 60.00 s	Increments of 0.01 s
Voltage threshold values:		
Upper voltage limit V_{max}	0.300 V to 340.000 V (phase-to-phase)	Increments of 0.001 V
Lower voltage limit V_{min}	0.300 V to 340.000 V (phase-to-phase)	Increments of 0.001 V
$V<$, for off-circuit conditions $V>$, for voltage present	0.300 V to 170.000 V (phase-to-phase) 0.300 V to 340.000 V (phase-to-phase)	Increments of 0.001 V Increments of 0.001 V
Differential values, changeover thresholds asynchronous/synchronous:		
Voltage differences $V2 > V1$; $V2 < V1$	0.000 V to 170.000 V	Increments of 0.001 V
Frequency difference $f2 > f1$; $f2 < f1$	0.000 Hz to 2.000 Hz (synchronous) 0.000 Hz to 4.000 Hz (asynchronous)	Increments of 0.001 Hz
Angular difference $\alpha2 > \alpha1$; $\alpha2 < \alpha1$	0° to 90°	Increments of 1°
Δf threshold ASYN ↔ SYN	0.010 Hz to 0.200 Hz	Increments of 0.001 Hz
Adjustments of the sides:		
Angle adjustment	0.0° to 360.0°	Increments of 0.1°
Voltage adjustment	0.500 to 2.000	Increments of 0.001
Circuit breaker		
Closing time of the circuit breaker	0.01 s to 0.60 s	Increments of 0.01 s

Dropout Ratio

Min./max. operating limit	1 % of the setting value
Voltage differential	10 % of the setting value or 0.5 V
De-energized/energized	5 % of the setting value
Frequency difference	3 mHz
Angular difference	0.1°

Measured Values of the Synchronization Function

Reference voltage V1 <ul style="list-style-type: none"> • Range • Tolerance at rated frequency 	In kV primary, in V secondary or in % V_{rated} Display always as phase-to-phase voltage 10 % to 120 % of V_{rated} $\pm 1\%$ of the measured value or 0.5% V_{rated}
Voltage to be synchronized V2 <ul style="list-style-type: none"> • Range • Tolerance at rated frequency 	In kV primary, in V secondary or in % V_{rated} Display always as phase-to-phase voltage 10 % to 120 % of V_{rated} $\pm 1\%$ of the measured value or 0.5% V_{rated}
Frequency of the voltage V1f1 <ul style="list-style-type: none"> • Range • Tolerance at rated frequency 	f1 in Hz 25 Hz $\leq f \leq$ 70 Hz 1 mHz
Frequency of the voltage V1f2 <ul style="list-style-type: none"> • Range • Tolerance at rated frequency 	f2 in Hz 25 Hz $\leq f \leq$ 70 Hz 1 mHz
Voltage difference V2-V1 <ul style="list-style-type: none"> • Range • Tolerance at rated frequency 	In kV primary, in V secondary or in % V_{rated} Display always as phase-to-phase voltage in relation to side 1 10 % to 120 % of V_{rated} $\pm 1\%$ of the measured value or 0.5% V_{rated}
Frequency difference f2-f1 <ul style="list-style-type: none"> • Range • Tolerance at rated frequency 	In mHz $f_{rated} \pm 10\%$ 1 mHz
Angular difference $\alpha_2-\alpha_1$ <ul style="list-style-type: none"> • Range • Tolerance at rated frequency 	In ° -180° to +180° 0,5°

Times

Measuring time, after switching on the variables	Approx. 80 ms
--	---------------

Operating Range

Voltage	20 V to 340 V
Frequency	$f_{rated} - 4 \text{ Hz} \leq f_{rated} \leq f_{rated} + 4 \text{ Hz}$

Tolerances

Tolerances of the voltage settings	2 % of the pickup value or 1 V
Voltage difference $V_2 > V_1$; $V_2 < V_1$	± V
Frequency difference $f_2 > f_1$; $f_2 < f_1$	10 mHz
Angular difference $\alpha_2 > \alpha_1$; $\alpha_2 < \alpha_1$	1°
Tolerance of all time settings	10 ms
Max. phase displacement angle	5° for $\Delta f \leq 1 \text{ Hz}$ 10° for $\Delta f > 1 \text{ Hz}$

12.56 Voltage Controller

Setting Values

General Information		
I reference for % values	0.20 A to 100 000.00 A	Increments of 0.01 A
V reference for % values	0.20 kV to 1 200.00 kV	Increments of 0.01 kV
Volt. cont. 2W		
Target voltage 1	40.00 kV to 1 360.00 kV	Increments of 0.01 kV
Target voltage 2		
Target voltage 3		
Target voltage 4		
Volt. cont. 3W and GC		
Target voltage 1 w1	40.00 kV to 1 360.00 kV	Increments of 0.01 kV
Target voltage 2 w1		
Target voltage 3 w1		
Target voltage 4 w1		
Target voltage 1 w2		
Target voltage 2 w2		
Target voltage 3 w2		
Target voltage 4 w2		
Volt. cont. 2W, 3W, and GC		
Bandwidth	0.2 % to 10.0 %	Increments of 0.1 %
T1 delay	5 s to 600 s	Increments of 1 s
T1 Inverse Min	5 s to 100 s	Increments of 1 s
T2 delay	0 s to 100 s	Increments of 1 s
Fast step down limit	0.0 % to 50.0 %	Increments of 0.1 %
Fast step down T delay	0.0 s to 10.0 s	Increments of 0.1 s
Fast step up limit	50.0 % to 0.0 %	Increments of -0.1 %
Fast step up T delay	0.0 s to 10.0 s	Increments of 0.1 s
Function monitoring	1 min to 120 min	Increments of 1 min
Line compensation LDC-Z		
Target voltage rising	0.0 % to 20.0 %	Increments of 0.1 %
Max load current	0.0 % to 500.0 %	Increments of 0.1 %
Line compensation LDC-X and R		
R line	0.0 Ω to 30.0 Ω	Increments of 0.1 Ω
X line	-30.0 Ω to 30.0 Ω	Increments of 0.1 Ω
Limiting values		
Vmin threshold	40.00 kV to 1 360.00 kV	Increments of 0.01 kV
Vmin time delay	0 s to 20 s	Increments of 1 s
Vmax threshold	40.00 kV to 1 360.00 kV	Increments of 0.01 kV
Vmax time delay	0 s to 20 s	Increments of 1 s
Blockings		
V< Threshold	40.00 kV to 1 360.00 kV	Increments of 0.01 kV
V< Time delay	0 s to 20 s	Increments of 1 s
≥ Threshold	10 % to 500 %	Increments of 1 %
≥ Time delay	0 s to 20 s	Increments of 1 s
I< Threshold	3 % to 100 %	Increments of 1 %

< Time delay	0 s to 20 s	Increments of 1 s
--------------	-------------	-------------------

Measured Values, Two-Winding Transformer

Measured Value	Description	Primary	Secondary	% Referenced to
V act.	Current, measured positive-sequence voltage (referenced to phase-to-phase)	kV	V	Target voltage of the primary system referenced to the rated voltage
ΔV act.	Voltage difference between the target voltage and the actual voltage	kV	V	Voltage difference referenced to the rated voltage of the controlled winding
I load	Current measured load current (positive-sequence system)	A	A	Load current referenced to the rated current of the winding
V max	Maximum positive sequence voltage ever measured (referenced to phase-to-phase)	kV	V	Maximum voltage of the winding referenced to the rated voltage of the winding
V min	Minimum positive-sequence voltage ever measured (reference to phase-to-phase)	kV	V	Minimum voltage of the winding referenced to the rated voltage of the winding
V target	Calculated target voltage with consideration of Z compensation	kV	V	Target voltage of the winding referenced to the rated voltage of the winding

Measured Values, Three-Winding Transformer

Measured Value	Description	Primary	Secondary	% Referenced to
Vact.w1	Actual voltage of winding 1	kV	V	Target voltage of the primary system referenced to the rated voltage
Vact.w2	Actual voltage of winding 2	kV	V	Target voltage of the primary system referenced to the rated voltage
ΔV act.	Voltage difference between the target voltage and the actual voltage	kV	V	Voltage difference referenced to the rated voltage of the controlled winding
I load w1	Load current of winding 1	A	A	Load current referenced to the rated current of winding 1
I load w2	Load current of winding 2	A	A	Load current referenced to the rated current of winding 2
Vmax 1	Maximum voltage of winding 1	kV	V	Maximum voltage of winding 1 referenced to the rated voltage of winding 1
Vmax 2	Maximum voltage of winding 2	kV	V	Maximum voltage of winding 2 referenced to the rated voltage of winding 2
Vmin 1	Minimum voltage of winding 1	kV	V	Minimum voltage of winding 1 referenced to the rated voltage of winding 1
Vmin 2	Minimum voltage of winding 2	kV	V	Minimum voltage of winding 2 referenced to the rated voltage of winding 2
V tar.w1	Target voltage of winding 1	kV	V	Target voltage of winding 1 referenced to the rated voltage of winding 1

A Red

Handwritten mark

Measured Value	Description	Primary	Secondary	% Referenced to
V tar.w2	Target voltage of winding 2	kV	V	Target voltage of winding 2 referenced to the rated voltage of winding 2

Measured Values Grid Coupling Transformer

Measured Value	Description	Primary	Secondary	% Referenced to
Vact.w1	Actual voltage of winding 1	kV	V	Target voltage of the primary system referenced to the rated voltage
Vact.w2	Actual voltage of winding 2	kV	V	Target voltage of the primary system referenced to the rated voltage
ΔV act.	Voltage difference between the target voltage and the actual voltage	kV	V	Voltage difference referenced to the rated voltage of the controlled winding
I load w1	Load current of winding 1	A	A	Load current referenced to the rated current of winding 1
I load w2	Load current of winding 2	A	A	Load current referenced to the rated current of winding 2
Vmax 1	Maximum voltage of winding 1	kV	V	Maximum voltage of winding 1 referenced to the rated voltage of winding 1
Vmax 2	Maximum voltage of winding 2	kV	V	Maximum voltage of winding 2 referenced to the rated voltage of winding 2
Vmin 1	Minimum voltage of winding 1	kV	V	Minimum voltage of winding 1 referenced to rated voltage of winding 1
Vmin 2	Minimum voltage of winding 2	kV	V	Minimum voltage of winding 2 referenced to rated voltage of winding 2
V tar.w1	Target voltage of winding 1	kV	V	Target voltage of winding 1 referenced to the rated voltage of winding 1
V tar.w2	Target voltage of winding 2	kV	V	Target voltage of winding 2 referenced to the rated voltage of winding 2

Dropout Ratio

Threshold of the voltage limit	About 0.99 of the setting value
Threshold of the current limit	About 0.99 of the setting value

12.57 Current-Balance Supervision



Setting Values

Release threshold	1 A @ 100 Irated	0.030 A to 35.000 A	increments of 0.001 A
	1 A @ 50 Irated		
	5 A @ 100 Irated	0.15 A to 175.00 A	increments of 0.01 A
	5 A @ 50 Irated		
	1 A @ 1.6 Irated	0.001 A to 1.600 A	increments of 0.001 A
	5 A @ 1.6 Irated	0.005 A to 8.000 A	increments of 0.001 A
Threshold value min/max	0.10 to 0.95		increments of 0.01
Tripping delay	0.00 s to 100.00 s		increments of 0.01 s

Dropout Ratio

Overcurrent dropout ratio	About 0.97
Undercurrent dropout ratio	About 1.05

Times

Tripping time	Approx. 500 ms
Dropout time	Approx. 500 ms

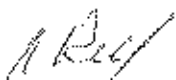

12.58 Voltage-Balance Supervision



Setting Values

Release threshold value	0,300 V to 170,000 V	Increments of 0,001 V
Threshold value min/max	0,58 to 0,95	Increments of 0,01
Tripping delay	0,00 s to 100,00 s	Increments of 0,01 s

Dropout Ratio

Overvoltage dropout ratio	Approx. 0,97
Undervoltage dropout ratio	Approx. 1,05

Times

Tripping time	Approx. 500 ms
Dropout time	Approx. 500 ms

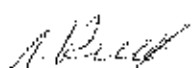

12.59 Current-Sum Supervision

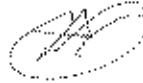

Setting Values

Slope of the characteristic curve		0.00 to 0.95	Increments of 0.01
Threshold	1 A @ 50 and 100 Irated	0.030 A to 10,000 A	Increments of 0.001 A
	5 A @ 50 and 100 Irated	0.15 A to 50.00 A	Increments of 0.01 A
	1 A @ 1.6 Irated	0.001 A to 1,600 A	Increments of 0.001 A
	5 A @ 1.6 Irated	0.005 A to 8,000 A	Increments of 0.001 A
Tripping delay		0.00 s to 100.00 s	Increments of 0.01 s

Dropout Ratio

Dropout ratio	About 0.97
---------------	------------

Times

Tripping time	Approx. 500 ms
Dropout time	Approx. 500 ms



A. Reiser

12.60 Voltage-Sum Supervision

Setting Values

Threshold value	0.300 V to 170.000 V	Increments of 0.001 V
Tripping delay	0.00 s to 100.00 s	Increments of 0.01 s

Dropout Ratio

Dropout ratio	Approx. 0.97
---------------	--------------

Times

Tripping time	Approx. 500 ms
Dropout time	Approx. 500 ms



A. Blum

12.61 Current Phase-Rotation Supervision

Setting Values

Tripping delay	0.00 s to 100.00 s	Increments of 0.01 s
Phase-rotation direction	A B C A C B	

Times

Tripping time	Approx. 500 ms
Dropout time	Approx. 500 ms

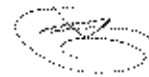

12.62 Voltage Phase-Rotation Reversal

Setting Values

Tripping delay	0.00 s to 100.00 s	Increments of 0.01 s
Phase-rotation direction	A B C A C B	

Times

Tripping time	Approx. 500 ms
Dropout time	Approx. 500 ms

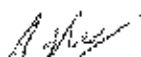

12.63 Trip-Circuit Supervision

Setting Values

Number of monitored circuits per circuit-breaker function group	1 to 3	
Operating mode per circuit	With 1 binary input	
	With 2 binary inputs	
Pickup and dropout time	About 1 s to 2 s	
Adjustable indication delay with 1 binary input	1.00 s to 600.00 s	increments of 0.01 s
Adjustable indication delay with 2 binary inputs	1.00 s to 600.00 s	increments of 0.01 s



A. Big

12.64 Analog Channel Supervision via Fast Current Sum

Times

Pickup times	Approx. 2 ms (faster than the fastest protection function)
Dropout time	Approx. 100 ms

Blockings

Blocked functions	All functions that process the measured values from this current measuring point (for example, differential protection).
-------------------	--



12.65 Measuring-Voltage Failure Detection

Setting Values

3ph.fail. - VA,VB,VC <		0.300 V to 340.000 V	Increments of 0.001 V
3ph.fail. - phs.curr.release	1 A @ 50 and 100 Irated	0.030 A to 35.000 A	Increments of 0.001 A
	5 A @ 50 and 100 Irated	0.15 A to 175.00 A	Increments of 0.01 A
	1 A @ 1.6 Irated	0.001 A to 1.600 A	Increments of 0.001 A
	5 A @ 1.6 Irated	0.005 A to 8.000 A	Increments of 0.001 A
3ph.fail. - phs.curr. jump	1 A @ 50 and 100 Irated	0.030 A to 35.000 A	Increments of 0.001 A
	5 A @ 50 and 100 Irated	0.15 A to 175.00 A	Increments of 0.01 A
	1 A @ 1.6 Irated	0.001 A to 1.600 A	Increments of 0.001 A
	5 A @ 1.6 Irated	0.005 A to 8.000 A	Increments of 0.001 A
Asym.fail. - time delay		0.00 s to 30.00 s	Increments of 0.01 s
SO 3ph.fail. - time delay		0.00 s to 30.00 s	Increments of 0.01 s

Dropout

The larger dropout differential (= | pickup value - dropout threshold |) of the following 2 criteria is used:

Dropout differential derived from the Dropout ratio parameter	
If this parameter is not available, a dropout ratio of 95 % applies to the overvoltage protection and a dropout ratio of 105 % applies to the undervoltage protection.	
Minimum absolute dropout differential	150 mV sec.

Times

Pickup time	Approx. 10 ms + OOT ¹²² at 50 Hz Approx. 10 ms + OOT at 60 Hz
Dropout time	Approx. 20 ms + OOT

Times

Use in function group Line	
Pickup time	Approx. 10 ms + OOT ¹²³ at 50 Hz Approx. 9 ms + OOT at 60 Hz
Use in other function group types	
Pickup time	Approx. 20 ms + OOT ¹²⁴ at 50 Hz Approx. 18 ms + OOT at 60 Hz

Frequency Operating Range

$0.9 \leq f_{rated} \leq 1.1$	According to specified tolerances
$10 \text{ Hz} \leq f < 0.9 f_{rated}$	Slightly expanded tolerances
$1.1 f_{rated} < f \leq 80 \text{ Hz}$	

¹²²OOT (Output Operating Time) Additional delay of the output medium used, see chapter 12.1.4 Relay Outputs

¹²³OOT (Output Operating Time) Additional delay of the output medium used, for example 5 ms with fast relays, see chapter 12.1.4 Relay Outputs

¹²⁴OOT (Output Operating Time) Additional delay of the output medium used, for example 5 ms with fast relays, see chapter 12.1.4 Relay Outputs

Handwritten signature

Handwritten signature

f < 10 Hz f > 80 Hz	Active
------------------------	--------

Tolerances

Currents	1 % of the setting value or 5 mA ($I_{rated} < 1 A$) or 25 mA ($I_{rated} > 5 A$), ($f_{rated} \pm 10\%$)
Voltages	0.5 % of the setting value or 0.5 V
Time delays	1 % of the setting value or 10 ms



12.66 Voltage-Transformer Circuit Breaker

Setting Values

Response time	0.000 s to 0.030 s	Increments of 0.001 s
---------------	--------------------	-----------------------

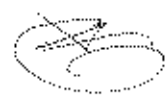

12.67 Operational Measured Values and Statistical Values

The following applies to the tolerances of currents and voltages:

- The values apply both to the RMS values and the absolute value and phase angle of the fundamental components.
- The values were determined for pure sinusoidal signals – without harmonics.

Voltages

V_A, V_B, V_C Voltage range	V secondary < 200 V secondary
Secondary rated voltage	100 V to 125 V AC
Measuring range	$(0.8 \text{ to } 2) \cdot V_{\text{rated}}$
Frequency range	49 Hz to 51 Hz at $f_{\text{rated}} = 50 \text{ Hz}$ 59 Hz to 61 Hz at $f_{\text{rated}} = 60 \text{ Hz}$
Tolerance	0.2 % of the measured value in the above mentioned measuring range
Frequency range (expanded)	40 Hz to 60 Hz at $f_{\text{rated}} = 50 \text{ Hz}$ 50 Hz to 70 Hz at $f_{\text{rated}} = 60 \text{ Hz}$
Tolerance	0.3 % of the measured value in the above mentioned measuring range
V_{AB}, V_{BC}, V_{CA} Voltage range	V secondary < 200 V
Secondary rated voltage	100 V to 125 V AC
Measuring range	$(0.8 \text{ to } 2) \cdot V_{\text{rated}}$
Frequency range	49 Hz to 51 Hz at $f_{\text{rated}} = 50 \text{ Hz}$ 59 Hz to 61 Hz at $f_{\text{rated}} = 60 \text{ Hz}$
Tolerance	0.2 % of the measured value in the above mentioned measuring range
Frequency range (expanded)	40 Hz to 60 Hz at $f_{\text{rated}} = 50 \text{ Hz}$ 50 Hz to 70 Hz at $f_{\text{rated}} = 60 \text{ Hz}$
Tolerance	0.3 % of the measured value in the above mentioned measuring range

Currents, Instrument Transformers

$I_A, I_B, I_C, I_{\Sigma}$ Current range	A secondary < $1.6 I_{\text{rated}}$
Rated currents	1 A, 5 A
Measuring range	$(0.1 \text{ to } 1.6) \cdot I_{\text{rated}}$
Frequency range	49 Hz to 51 Hz at $f_{\text{rated}} = 50 \text{ Hz}$ 59 Hz to 61 Hz at $f_{\text{rated}} = 60 \text{ Hz}$
Tolerance	0.15 % of the measured value in the above mentioned measuring range
Frequency range (expanded)	40 Hz to 60 Hz at $f_{\text{rated}} = 50 \text{ Hz}$ 50 Hz to 70 Hz at $f_{\text{rated}} = 60 \text{ Hz}$
Tolerance	0.3 % of the measured value in the above mentioned measuring range

A. R.

Currents, Protection-Class Current Transformer

$I_N, I_B, I_C, 3I_0$ Current range	A secondary < 100 I_{rated}
Rated currents	1 A, 5 A
Measuring range	0.1 to 25 A
Frequency range	49 Hz to 51 Hz at $f_{rated} = 50$ Hz 59 Hz to 61 Hz at $f_{rated} = 60$ Hz
Tolerance	0.2 % of the measured value in the above mentioned measuring range
Frequency range (expanded)	40 Hz to 60 Hz at $f_{rated} = 50$ Hz 50 Hz to 70 Hz at $f_{rated} = 60$ Hz
Tolerance	0.3 % of the measured value in the above mentioned measuring range

Currents, Protection-Class Current Transformer

$I_N, I_B, I_C, 3I_0$ Current range	A secondary < 50 I_{rated}
Rated currents	1 A, 5 A
Measuring range	0.1 to 25 A
Frequency range	49 Hz to 51 Hz at $f_{rated} = 50$ Hz 59 Hz to 61 Hz at $f_{rated} = 60$ Hz
Tolerance	0.15 % of the measured value in the above mentioned measuring range
Frequency range (expanded)	40 Hz to 60 Hz at $f_{rated} = 50$ Hz 50 Hz to 70 Hz at $f_{rated} = 60$ Hz
Tolerance	0.6 % of the measured value in the above mentioned measuring range

Currents, Sensitive Ground-Current Transformer

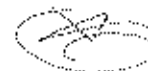

$3I_0$ Current range	A secondary < 1.6 I_{rated}
Rated currents	1 A, 5 A
Measuring range	$(0.1 \text{ to } 1.6) \cdot I_{rated}$
Frequency range	49 Hz to 51 Hz at $f_{rated} = 50$ Hz 59 Hz to 61 Hz at $f_{rated} = 60$ Hz
Tolerance	0.15 % of the measured value in the above mentioned measuring range
Frequency range (expanded)	40 Hz to 60 Hz at $f_{rated} = 50$ Hz 50 Hz to 70 Hz at $f_{rated} = 60$ Hz
Tolerance	0.3 % of the measured value in the above mentioned measuring range

Phase Angle

Φ_V	"
Frequency range	47.5 Hz to 52.5 Hz at $f_{rated} = 50$ Hz 57.5 Hz to 62.5 Hz at $f_{rated} = 60$ Hz



Tolerance ΦV	0,2 ° at rated voltage
ϕI	°
Frequency range	47,5 Hz to 52,5 Hz at $f_{rated} = 50$ Hz 57,5 Hz to 62,5 Hz at $f_{rated} = 60$ Hz
Tolerance ΦI	0,2 ° at rated current

Power Values

Active power P	W secondary
Measuring range	$ \cos\phi \geq 0.01$
Voltage range	$(0.8 \text{ to } 1.2) \cdot V_{rated}$
Current range	$(0.1 \text{ to } 2) \cdot I_{rated}$
Frequency range	49 Hz to 51 Hz at $f_{rated} = 50$ Hz 59 Hz to 61 Hz at $f_{rated} = 60$ Hz
Tolerance	0.3 % of the measured value in the above mentioned measuring range
Frequency range (expanded)	40 Hz to 69 Hz at $f_{rated} = 50$ Hz 50 Hz to 70 Hz at $f_{rated} = 60$ Hz
Tolerance	0.5 % of the measured value in the above mentioned measuring range
Reactive power Q	var secondary
Measuring range	$ \cos\phi \geq 0.984$
Voltage range	$(0.8 \text{ to } 1.2) \cdot V_{rated}$
Current range	$(0.1 \text{ to } 2) \cdot I_{rated}$
Frequency range	49 Hz to 51 Hz at $f_{rated} = 50$ Hz 59 Hz to 61 Hz at $f_{rated} = 60$ Hz
Tolerance	1.0 % of the measured value in the above mentioned measuring range
Frequency range (expanded)	40 Hz to 69 Hz at $f_{rated} = 50$ Hz 50 Hz to 70 Hz at $f_{rated} = 60$ Hz
Tolerance	1.5 % of the measured value in the above mentioned measuring range
Apparent power S	VA
Measuring range	$(0.01 \text{ to } 2) \cdot S_{rated}$
Voltage range	$(0.8 \text{ to } 1.2) \cdot V_{rated}$
Current range	$(0.01 \text{ to } 2) \cdot I_{rated}$
Frequency range	49 Hz to 51 Hz at $f_{rated} = 50$ Hz 59 Hz to 61 Hz at $f_{rated} = 60$ Hz
Tolerance	0.3 % of the measured value in the above mentioned measuring range
Frequency range (expanded)	40 Hz to 69 Hz at $f_{rated} = 50$ Hz 50 Hz to 70 Hz at $f_{rated} = 60$ Hz
Tolerance	0.5 % of the measured value in the above mentioned measuring range



Frequency

Frequency f	Hz
-------------	----

Handwritten mark

12.67 Operational Measured Values and Statistical Values

Range	$f_{rated} - 0.20 \text{ Hz} < f_{rated} < f_{rated} + 0.20 \text{ Hz}$
Tolerance	$\pm 5 \text{ mHz}$ in the V_{rated} range
Range	$f_{rated} - 3.00 \text{ Hz} < f_{rated} < f_{rated} + 3.00 \text{ Hz}$
Tolerance	$\pm 10 \text{ mHz}$ in the V_{rated} range
Frequency range (expanded)	25 Hz to 80 Hz; operational measured values 10 Hz to 80 Hz; functional measured values, system frequency
Tolerance	20 mHz in the range $f_{rated} \pm 10\%$ for rated values

Statistical Values of the Device

Device operating hours	h
Range	0 to 9 999 999 h
Tolerance	1 h

Statistical Values of the Circuit Breaker

Op.cnt. (operation counter)	
Range	0 to 999 999 999
Tolerance	None
Σ Off (sum of the primary currents switched off)	A, kA, MA, GA, TA, PA primary
Range	0 to 9.2 e15
Operating hours	h
Range	0 to 9 999 999 h
Tolerance	1 h
Circuit breaker open hours	h
Range	0 to 9 999 999 h
Tolerance	1 h

Statistical Values of the Disconnecter

Op.cnt. (operation counter)	
Range	0 to 999 999 999
Tolerance	None

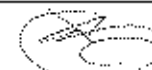

Handwritten initials 'AP' in the bottom left corner.

12.68 Energy Values

Setting Values

Active energy W_p	kWh, MWh, GWh
Reactive energy W_q	kvarh, Mvarh, Gvarh
Range	$\leq 2\%$ for $I > 0.1 I_{rated}$ $V > 0.1 V_{rated}$ $ \cos\phi \geq 0.707$
Tolerance at rated frequency	1 %

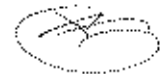

Handwritten mark

12.69 Phasor Measurement Unit

Accuracy

As per IEEE Std C37.118.1a-2013

Synchrophasor Standard

IEEE Std C37.118.1-2011



Albert

12.70 Circuit-Breaker Wear Monitoring

Setting Values

Threshold value	ΣI^2 -method stage	0 to 10 000 000	Increments of 1
	$2P$ method stage	0 to 10 000 000	Increments of 1
	I^2t -method stage	0.00 $I_{ratec}^2 s$ to 21 400 000.00 $I_{ratec}^2 s$	Increments of 0.01
CB opening time		0.001 s to 0.500 s	Increments of 0.001 s
CB break time		0.001 s to 0.600 s	Increments of 0.001 s
CB make time		0.001 s to 0.600 s	Increments of 0.001 s
Exponent for the ΣI^2 method		1.0 to 3.0	Increments of 0.1
Switching cycles at I_{ratec}		100 to 1 000 000	Increments of 1
Rated short-circuit breaking current I_{sc}		10 to 100 000	Increments of 1
Switching cycles at I_{cr}		1 to 1000	Increments of 1
Level of warning 1		1 % to 100 %	Increments of 1 %
Level of warning 2		1 % to 100 %	Increments of 1 %
Operating current threshold	1 A @ 50 and 100 Irated	0.030 A to 35.000 A	Increments of 0.001 A
	5 A @ 50 and 100 Irated	0.15 A to 175.00 A	Increments of 0.01 A
	1 A @ 1.6 Irated	0.001 A to 1.600 A	Increments of 0.001 A
	5 A @ 1.6 Irated	0.005 A to 8.000 A	Increments of 0.001 A
Delay correction time		-0.050 s to 0.050 s	Increments of 0.001 s

Tolerances

Tolerance of the measured value make time	± 2 ms
---	------------





12.71 CFC

Typical response times and maximum number of ticks of the CFC task levels:

Task Level	Time (in ms)	Ticks for Non-Modular Devices with CP100	Ticks for Modular Devices with CP200	Ticks for Modular Devices with CP300
Fast Event-Triggered	<1	500	500	1000
Event-Triggered	<10	12 367	12757	14702
Interlocking	<10	117 564 in total	121 537 in total	141 398 in total
Measurement	250			

The times describe the response time of a typical CFC chart at the respective task level. The maximum number of ticks applies to a typical load for the device based on the application template **Directional time-overcurrent protection, grounded electrical power system**. The maximum number can be lower in case of extensive protection applications.

The task level **Measurement** runs in cycles every 500 ms. All other task levels are event triggered.

In order to estimate the tick consumption of a CFC chart, you can use the following formula:

$$T_{\text{chart}} = 5 \cdot n_{\text{inp}} + 5 \cdot n_{\text{outp}} + T_{\text{level}} + \sum_i T_{\text{int}} + \sum_j T_{\text{block}}$$

where:

- n_{inp} Number of indications routed as input in the CFC chart
- n_{outp} Number of indications routed as output in the CFC chart
- T_{level} 101 Ticks in Fast Event-Triggered Level
104 Ticks in Event-Triggered Level
54 Ticks in Measurement Level
74 Ticks in Interlocking Level
- T_{int} Number of internal connections between 2 CFC blocks in one chart
- T_{block} Used ticks per CFC block (see Technical Data)



Table 12-6 Ticks of the individual CFC Blocks

Element	Ticks
ABS_D	2.3
ABS_R	1.5
ACOS_R	6.9
ADD_D4	3.4
ADD_R4	3.3
ADD_XMV	6.4
ALARM	1.8
AND_SPS	1.1
AND_IO	2.9
APC_DEF	1.2
APC_EXC	1.0
APC_INFO	3.9
ASIN_R	1.3
ATAN_R	1.2
BLINK	1.3
BOOL_CNT	2.0
BOOL_INT	1.5

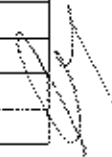

APA

Element	Ticks
BSC_DEF	1.3
BSC_EXE	1.1
BSC_INFO	2.7
BUILD_ACD	2.9
BUILD_ACT	2.2
BUILD_BSC	1.2
BUILD_CMV	2.3
BUILD_DEL	2.1
BUILD_DPS	1.4
BUILD_ENS	1.3
BUILD_INS	0.5
BUILD_Q	0.8
BUILD_SPS	0.6
BUILD_WYE	3.2
BUILD_XMV	2.9
BUILD_Q	3.0
CIART_STATE	5.9
CMP_DPS	1.5
CON_ACD	0.7
CON_ACT	0.5
CONNECT	0.4
COS_R	2.5
CTD	1.8
CTU	1.6
CIUD	2.3
DINT_REAL	3.0
DINT_UINT	3.0
DIV_D	2.9
DIV_R	1.6
DIV_XMV	2.2
DPC_DEF	0.4
DPC_EXE	0.4
DPC_INFO	1.1
DPC_OUT	1.3
DPS_SPS	1.0
LDRAGI_R	1.7
EQ_D	1.0
EQ_R	1.9
EXP_R	1.5
EXPT_R	2.7
F_TRGM	0.3
F_TRIG	0.3
FF_D	0.9
FF_D_MEM	1.4
FF_RS	0.7
FF_RS_MEM	1.2
IT_SR	0.8

AKU

Element	Ticks
FF_SR_MEM	1.1
GE_D	0.9
GE_R	1.1
GT_D	0.9
GT_R	1.2
HOLD_D	1.1
HOLD_R	1.0
INC_INFO	0.9
LE_D	1.1
LE_R	1.1
LIML_R	1.5
LIMU_R	1.5
LN_R	3.3
LOG_R	1.2
LOOP	1.5
LT_D	0.9
LT_R	0.9
MAX_D	0.9
MAX_R	1.4
MEMORY_D	0.9
MEMORY_R	1.1
MIN_D	0.7
MIN_R	1.3
MOD_D	1.5
MUL_D4	2.5
MUL_R4	2.7
MUL_XMV	2.8
MUX_D	1.2
MUX_R	0.9
NAND10	3.5
NE_D	0.9
NE_R	0.9
NEG	1.2
NEG_SPS	0.8
NLC_1Z	7.1
NLC_XMV	4.4
NLC_ZP	3.0
NOR10	3.2
OR_DYN	1.1
OR_SPS	1.3
OR10	2.6
R_TRGM	0.4
R_TRIG	0.4
REAL_DINT	3.0
REAL_SXMV	3.0
SIN_R	0.8
SPC_DEF	0.4

APU

M

Element	Ticks
SPC_EXE	0.4
SPC_INFO	0.4
SPC_OUT	0.4
SPLIT_ACD	3.4
SPLIT_ACT	1.0
SPLIT_BSC	1.3
SPLIT_CMV	2.2
SPLIT_DEL	2.0
SPLIT_DPS	1.0
SPLIT_INS	0.5
SPLIT_Q	0.7
SPLIT_SPS	0.8
SPLIT_WYE	2.6
SPLIT_XMV	2.1
SORT_R	0.6
SUB_D	1.3
SUB_R	1.6
SUB_XMV	2.4
SUBST_B	1.0
SUBST_BQ	1.5
SUBST_D	1.0
SUBST_R	1.0
SUBST_XQ	1.4
SXMV_REAL	3.0
TAN_R	1.1
TLONG	2.2
TOF	1.0
TON	1.1
TT	2.5
TSHORT	1.9
UINT_DINT	3.0
XOR2	2.6

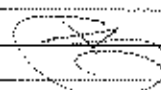

A. Reij

