

U-	Isc	Rated uninterrupted current (40 °C) [A]										Circuit-breaker type	
		H=461			H=589		H=599			H=610			H=635
kV	kA	D=424			D=424		D=424			D=459		D=459	
		u/l=205			u/l=310		u/l=310			u/l=310		u/l=310	
		l/g=217.5			l/g=238		l/g=237.5			l/g=237		l/g=237.5	
		P=150	P=210	P=275	P=210	P=275	P=150	P=210	P=275	P=210	P=275	P=275	
	W=450	W=570	W=700	W=570	W=700	W=450	W=570	W=700	W=600	W=750	W=750		
	16		1250									VD4 17.12.16 p210	
	20		1250									VD4 17.12.20 p210	
	25		1250									VD4 17.12.25 p210	
	31.5		1250									VD4 17.12.32 p210	
	40				1250							VD4 17.12.40 p210	
	50								1250			VD4 17.12.50 p210	
	20							1600				VD4 17.16.20 p210	
	25							1600				VD4 17.16.25 p210	
	31.5							1600				VD4 17.16.32 p210	
	40				1600							VD4 17.16.40 p210	
	50								1600			VD4 17.16.50 p210	
	20							2000				VD4 17.20.20 p210	
	25							2000				VD4 17.20.25 p210	
	31.5							2000				VD4 17.20.32 p210	
	40							2000				VD4 17.20.40 p210	
	50								2000			VD4 17.20.50 p210	
	20							2500				VD4 17.25.20 p210	
	25							2500				VD4 17.25.25 p210	
	31.5							2500				VD4 17.25.32 p210	
	16			630								VD4 17.06.16 p275	
	20			630								VD4 17.06.20 p275	
	25			630								VD4 17.06.25 p275	
	31.5			630								VD4 17.06.32 p275	
	16			1250								VD4 17.12.16 p275	
	20			1250								VD4 17.12.20 p275	
	25			1250								VD4 17.12.25 p275	
	31.5			1250								VD4 17.12.32 p275	
	40					1250						VD4 17.12.40 p275	
	50								1250			VD4 17.12.50 p275	
	20							1600				VD4 17.16.20 p275	
	25							1600				VD4 17.16.25 p275	
	31.5							1600				VD4 17.16.32 p275	
	40					1600						VD4 17.16.40 p275	
	50								1600			VD4 17.16.50 p275	
	20							2000				VD4 17.20.20 p275	
	25							2000				VD4 17.20.25 p275	
	31.5							2000				VD4 17.20.32 p275	
	40							2000				VD4 17.20.40 p275	
	50								2000			VD4 17.20.50 p275	
	20							2500				VD4 17.25.20 p275	
	25							2500				VD4 17.25.25 p275	
	31.5							2500				VD4 17.25.32 p275	
	40							2500				VD4 17.25.40 p275	
	50								2500			VD4 17.25.50 p275	
	20									3150		VD4 17.32.20 p275	
	25									3150		VD4 17.32.25 p275	
	31.5									3150		VD4 17.32.32 p275	
	40									3150		VD4 17.32.40 p275	
	50									3150		VD4 17.32.50 p275	

H = Height of the circuit-breaker.  
 W = Width of the circuit-breaker.  
 D = Depth of the circuit-breaker.  
 u/l = Distance between bottom and top terminal.  
 l/g = Distance between the bottom terminal and the resting surface of the circuit-breaker.  
 P = Pole horizontal centre distance.

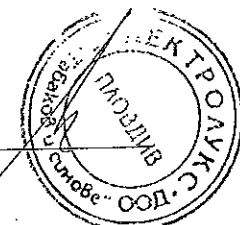
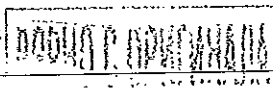

VD4 fixed circuit-breaker without bottom and top terminals (24 kV)

Ur	Isc	Rated uninterrupted current (40 °C) [A]			Circuit-breaker type
		H=631 D=424 u/l=310 l/g=282.5 P=210 W=570	H=642 D=424 u/l=310 l/g=282.5 P=275 W=700		
24	16	630			VD4 24.06.16 p210
		630			VD4 24.06.20 p210
		630			VD4 24.06.25 p210
	20	1250			VD4 24.12.16 p210
		1250			VD4 24.12.20 p210
		1250			VD4 24.12.25 p210
	25	1250			VD4 24.12.32 p210
			630		VD4 24.06.16 p275
			630		VD4 24.06.20 p275
	31.5		630		VD4 24.06.25 p275
			1250		VD4 24.12.16 p275
			1250		VD4 24.12.20 p275
24	16			1600	VD4 24.16.16 p275
				1600	VD4 24.16.20 p275
				1600	VD4 24.16.25 p275
	20			1600	VD4 24.16.32 p275
				2000	VD4 24.20.16 p275
				2000	VD4 24.20.20 p275
	25			2000	VD4 24.20.25 p275
				2000	VD4 24.20.32 p275
				2500	VD4 24.25.25 p275
			2500	VD4 24.25.32 p275	

- H = Height of the circuit-breaker.
- W = Width of the circuit-breaker.
- D = Depth of the circuit-breaker.
- u/l = Distance between bottom and top terminal.
- l/g = Distance between the bottom terminal and the resting surface of the circuit-breaker.
- P = Pole horizontal centre distance.

VD4 fixed circuit-breaker without bottom and top terminals (36 kV)

Ur	Isc	Rated uninterrupted current (40 °C) [A]	
KV	kA	H=876	Circuit-breaker type
		D=478.5	
		u/l=328	
		l/g=428.5	
		P=275	
		W=786	
36	31.5	1250 A	VD4 36.12.32 p275
		1600 A	VD4 36.16.32 p275
		2000 A	VD4 36.20.32 p275
		2500 A (*)	VD4 36.25.32 p275

- H = Height of the circuit-breaker.
- W = Width of the circuit-breaker.
- D = Depth of the circuit-breaker.
- u/l = Distance between bottom and top terminal.
- l/g = Distance between the bottom terminal and the resting surface of the circuit-breaker.
- P = Pole horizontal centre distance.
- (\*) = To be released. Contact ABB.

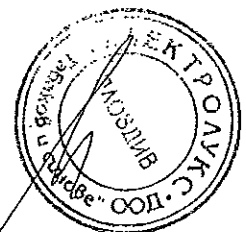
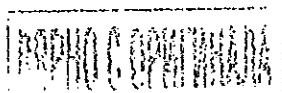

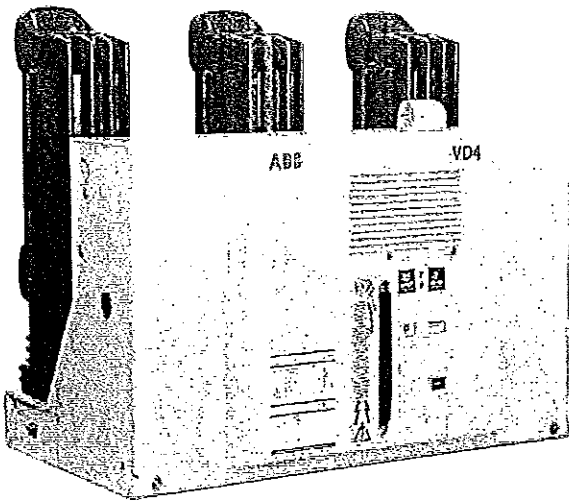

VD4 – up to 24 kV

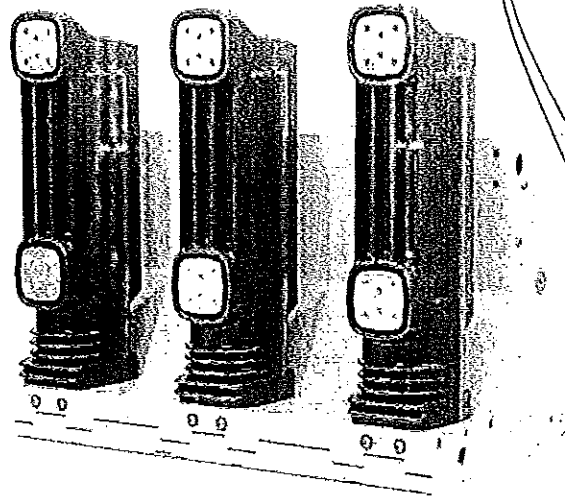

VD4 – up to 24 kV

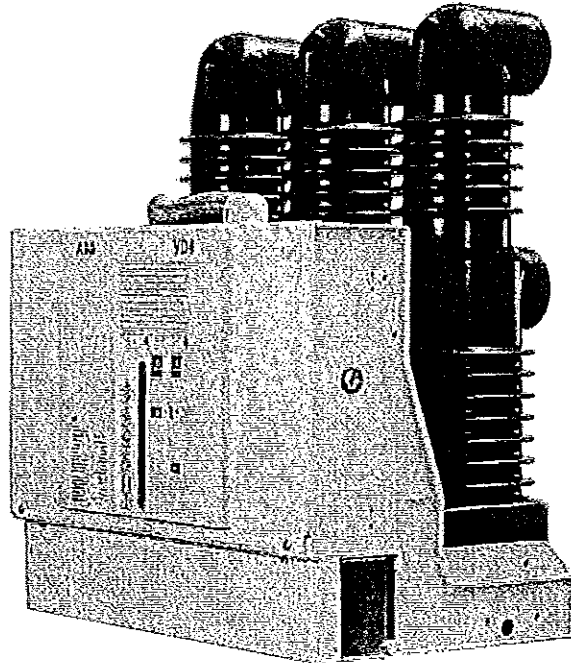

VD4 - 36 kV

### 5.4.3. Standard fittings for fixed circuit-breakers

The basic versions of the fixed circuit-breakers are three-pole and fitted with:

- EL type manual operating mechanism
- mechanical signalling device for closing spring charged/discharged
- mechanical signalling device for circuit-breaker open/closed
- closing pushbutton, opening pushbutton and operation counter

- set of ten circuit-breaker open/closed auxiliary contacts
- Note: with the set of ten auxiliary contacts supplied as standard and the maximum number of electrical applications possible, three make contacts (signalling circuit-breaker open) and five break contacts (signalling circuit-breaker closed) are available.
- lever for manual closing spring charging
  - auxiliary circuit support terminal box.

ВАРНО С ОБРАЗЦА

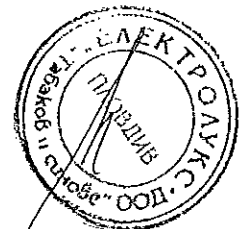

## 5.5. Withdrawable circuit-breakers

The withdrawable circuit-breakers up to 24 kV are available for UniGear ZS1 and UniSec switchgear, PowerCube modules (see fig. 5a) and for ZS8.4 switchgear (see fig. 5b).

The 36 kV circuit-breakers are available for ZS2 switchgear. They consist of a truck on which the supporting structure of the circuit-breaker is fixed.

### Circuit-breakers for UniGear ZS1 and UniSec switchgear and for PowerCube modules (fig. 5a)

The cord with the connector (14) (plug) for connection of the operating mechanism electrical accessories comes out of the connection (15).

The strikers for operating the contacts (connected/isolated) placed in the switchgear are fixed in the top part of the circuit-breaker.

The shutter actuator (9) (roller (18) for UniSec version) are provided for operating the segregation shutters of the medium voltage contacts of the enclosure or of the switchgear are fixed on the sides of the circuit-breaker.

The crosspiece with the handles (17) for hooking up the circuit-breaker for the racking-in/out operations by means of the special operating lever (16) is mounted on the front part of the circuit-breaker truck.

The circuit-breaker is completed with the isolating contacts (8).

The withdrawable circuit-breaker is fitted with special locks on the front crosspiece, which allow hooking up into the corresponding couplings of the switchgear.

The locks can only be activated by the handles with the truck fully resting against the crosspiece.

The operating lever (16) must be fully inserted (also see par. 7.5.). A lock prevents the truck from advancing into the enclosure or fixed part when the earthing switch is closed.

Another lock prevents racking-in and racking-out with the circuit-breaker closed. With the truck in an intermediate position between isolated and connected, a further lock prevents circuit-breaker closing (either mechanical or electrical).

A locking magnet is also mounted on the truck which, when de-energised, prevents the truck racking-in operation.

On request, an interlock is available which prevents racking-in of the circuit-breaker with the door open, and door opening with the circuit-breaker closed.

The lever for loading the closing spring (1) in the manual mode is built into the operating mechanism. The spring is loaded by repeatedly lowering the lever with linear movements until the yellow indicator (6) appears to show that loading is complete. The spring can only be loaded with the switchgear door open. Comply with the instructions in the UniGear switchgear manual for the operations that can be performed with the door open.

Note: on request, the closing spring loading device for withdrawable circuit-breakers for UniGear switchgear can be supplied with the lever outside the operating mechanism and a rotary loading movement. This device is part of the standard equipment for VD4/ZS8 withdrawable circuit-breakers only (see detail 1 of Fig. 5b on the next page). This rotary loading device allows the closing spring to be loaded with the switchgear door closed.

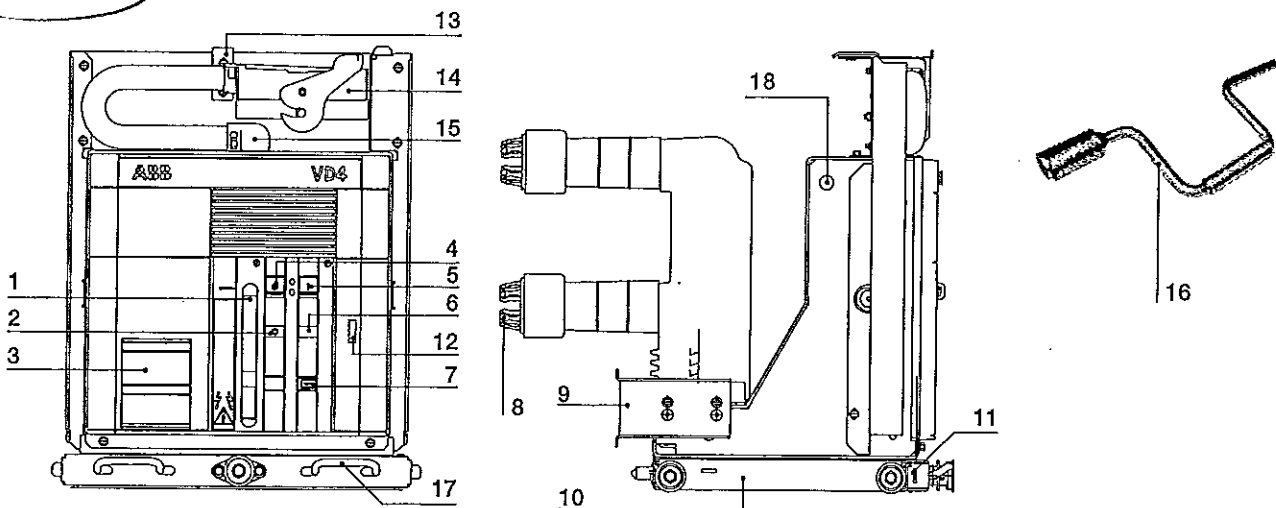

#### Caption

- 1 Lever for manually charging the closing spring
- 2 Signalling device for circuit-breaker open/closed
- 3: Rating plate
- 4 Opening pushbutton
- 5 Closing pushbutton
- 6 Signalling device for closing spring charged/discharged
- 7 Operation counter
- 8 Isolating contacts

- 9 Slide for operating the switchgear shutters (UniGear ZS1, PowerCube, ZS8.4)
- 10 Truck
- 11 Locks for hooking into the fixed part
- 12 Mechanical override of the undervoltage release (on request)
- 13 Strikers for activating the contacts placed in the enclosure
- 14 Connector (plug)
- 15 Cabling connection
- 16 Operating lever for circuit-breaker racking-in/out
- 17 Handles for activating the locks (11)
- 18 Shutters actuator (for UniSec version only)

Fig. 5a





**Circuit-breakers for ZS8.4 switchgear (fig. 5b)**

The socket (13) takes the connector (plug) placed in the switchgear.

The slides (9) for operating the segregation shutters of the medium voltage contacts of the switchgear are fixed on the sides of the circuit-breaker.

The crosspiece with the handles (17) for hooking up the circuit-breaker for the racking-in/out operations by means of the special operating lever (16) is mounted on the front part of the circuit-breaker truck.

The circuit-breaker is completed with the isolating contacts (8). The withdrawable circuit-breaker is fitted with special locks, described below (see fig. 5c - 5d).

**1) Prevention of traverse with circuit-breaker closed**

With the circuit-breaker closed, the feeler pin (16 - fig. 5c) prevents the shutter sliding (19 - fig. 5c) and therefore insertion of the lever (20 - fig. 5c) for traverse of the apparatus.

**2) Prevention of traverse with socket-plug disconnected**

When the plug is not inserted in the socket (13), the stem (21 - fig. 5c) prevents the plate (22 - fig. 5c) lifting and traverse of the apparatus.

**3) Prevention of switchgear door closing with socket-plug disconnected (\*)**

When the plug is not inserted in the socket (13), the feeler pin (23 - fig. 5d) prevents door closing.

**4) Prevention of circuit-breaker racking-out with the socket-plug connected (\*)**

When the plug is inserted in the socket (13), the lock bolt (29 - fig. 5d) hits the pin (30 - fig. 5d) preventing the apparatus from being racked out of the switchgear.

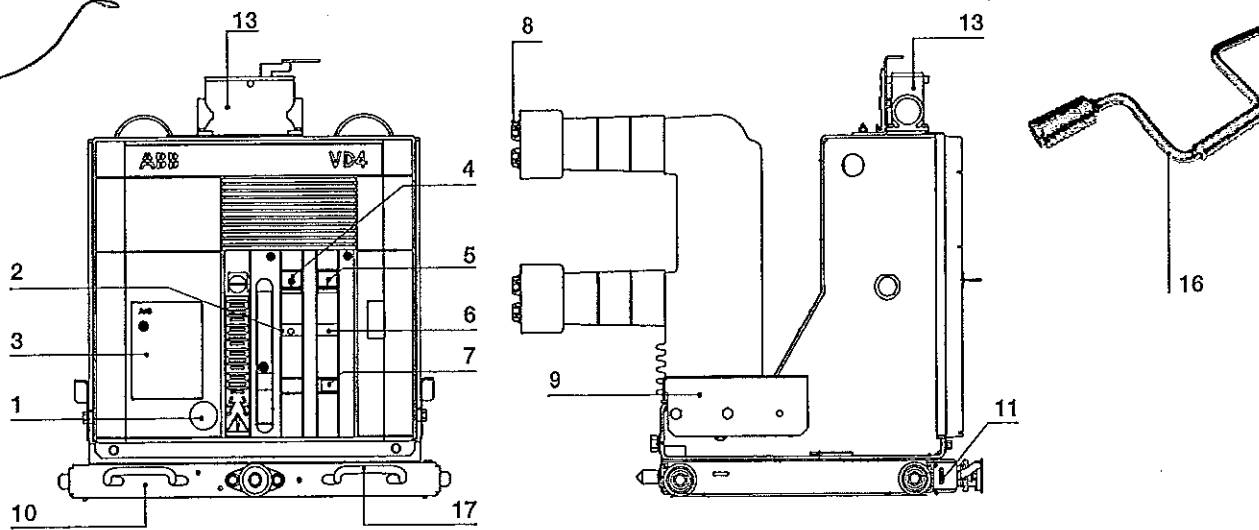

**Caption**

- 1 Coupling for the manual closing spring charging lever (\*)
- 2 Signalling device for circuit-breaker open/closed
- 3 Rating plate
- 4 Opening pushbutton
- 5 Closing pushbutton
- 6 Signalling device for closing spring charged/discharged
- 7 Operation counter
- 8 Isolating contacts

- 9 Slide for operating the switchgear shutters
- 10 Truck
- 11 Locks for hooking into the fixed part
- 13 Connector (plug)
- 16 Operating lever for circuit-breaker racking-in/out (a special version is provided for VD4/ZS8 Preussen Elektra EON circuit-breakers)
- 17 Handles for activating the locks (11)

(\*) Only VD4/ZS8 Preussen - Elektra EON version.

**Fig. 5b**

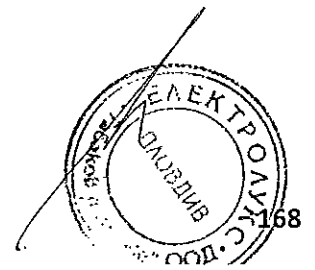
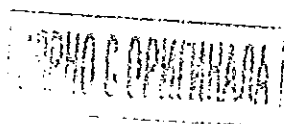

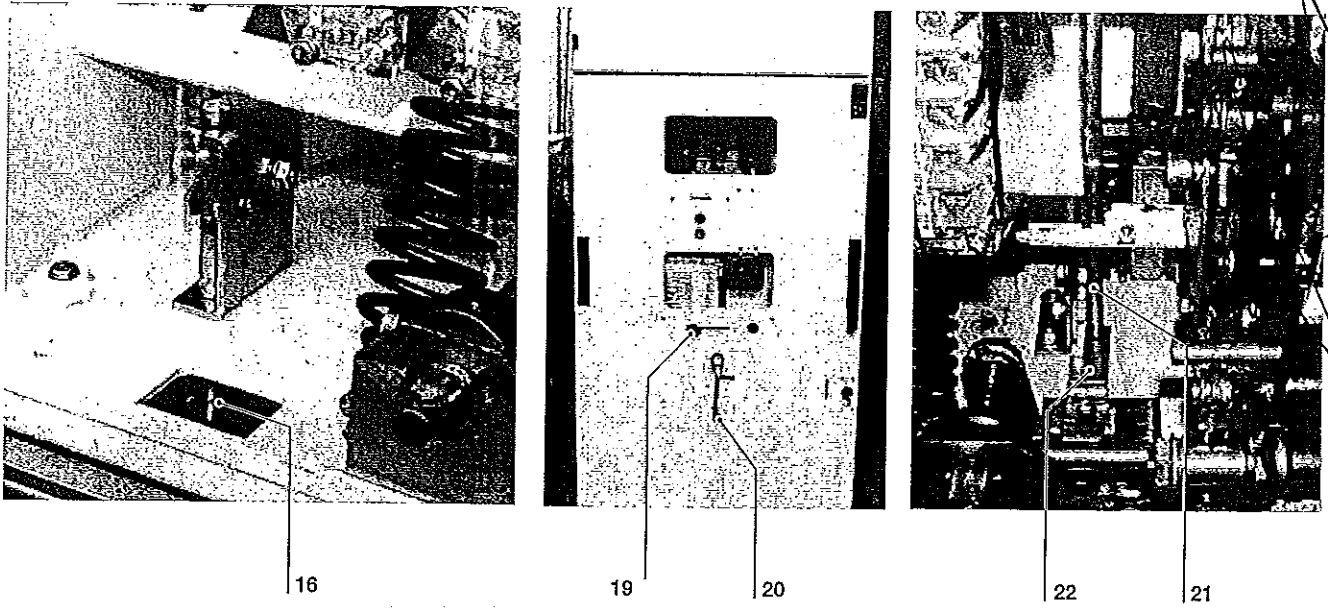

Fig. 5c

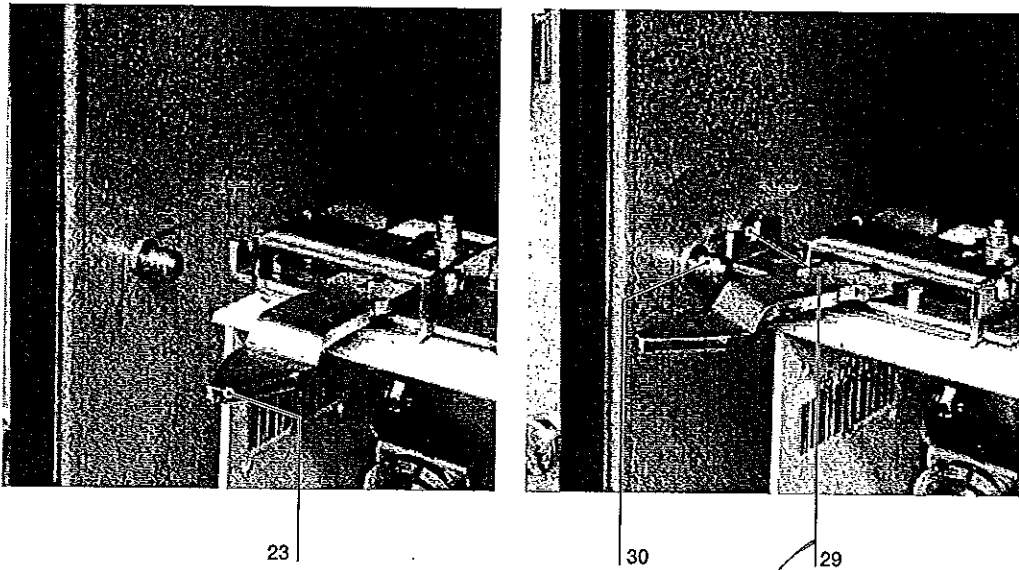
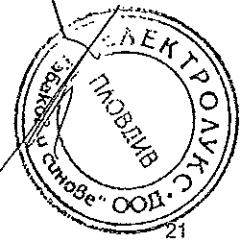

Fig. 5d

РАДИО С ОБОЗНАЧЕНИЯМИ



5.5.1. General characteristics of withdrawable circuit-breakers for UniGear ZS1 switchgear

General characteristics of withdrawable circuit-breakers for UniGear ZS1 switchgear (12 kV)

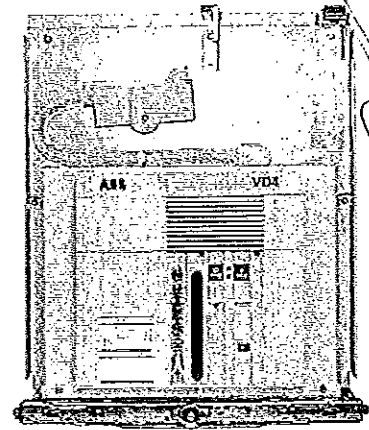

Circuit-breaker	VD4/P 12 (2)							
Standards	IEC 62271-100 • VDE 0671; CEI EN 62271-100- File 7642 •							
Rated voltage	Ur [kV]	12						
Rated insulation voltage	Us [kV]	12						
Withstand voltage at 50 Hz	Ud (1 min) [kV]	28						
Impulse withstand voltage	Up [kV]	75						
Rated frequency	fr [Hz]	50-60						
Rated normal current (40 °C) (1)	Ir [A]	630	1250	1250	1250	1250	1600	1600
		16	16	-	-	-	-	-
Rated breaking capacity (rated short-circuit breaking current symmetrical)	Isc [kA]	20	20	-	-	-	20	20
		25	25	-	-	-	25	25
		31.5	31.5	-	-	-	31.5	31.5
		-	-	40	40	-	-	-
		-	-	-	50	-	-	-
		16	16	-	-	-	-	-
Rated short-time withstand current (3s)	Ik [kA]	20	20	-	-	-	20	20
		25	25	-	-	-	25	25
		31.5	31.5	-	-	-	31.5	31.5
		-	-	40	40	-	-	-
		-	-	-	50	-	-	-
		40	40	-	-	-	-	-
		50	50	-	-	-	50	50
		63	63	-	-	-	63	63
Making capacity	Ip [kA]	80	80	-	-	-	80	80
		-	-	100	100	-	-	-
		-	-	-	125	-	-	-
		Operation sequence	[ O - 0.3 s - CO - 15 s - CO ]	•	•	•	•	•
Opening time	[ms]	33 ... 60						
Arcing time	[ms]	10 ... 15						
Total breaking time	[ms]	43 ... 75						
Closing time	[ms]	60 ... 80						
Maximum overall dimensions	H [mm]	628	628	691	691	691	691	691
	W [mm]	503	503	653	853	681	653	853
	D [mm]	662	662	641	642	643	642	642
	Pole distance P [mm]	150	150	210	275	210	210	275
Weight	[kg]	116	116	174	176	180	160	166
Standardised table of dimensions	TN	7412	7412	-	-	-	7415	7416
	1VCD	-	-	003284	003286	003444	-	-
Operating temperature	[°C]	- 5 ... + 40						
Tropicalization	IEC: 60068-2-30, 60721-2-1	•						
Electromagnetic compatibility	IEC: 62271-1	•						

(1) Rated current guaranteed with circuit-breaker installed in UniGear ZS1 switchgear and with 40 °C ambient temperature.  
 (2) Up to 4000 A with forced ventilation.  
 (3) Circuit-breakers up to 1250 A and 31.5 kA have polyamide poles.

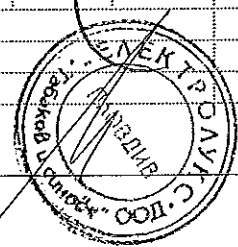

12												
12												
28												
75												
50-60												
1600	1600	1600	1600	2000	2000	2000	2000	2500	2500	3150	3150	
-	-	-	-	-	-	-	-	-	-	-	-	-
-	-	-	-	20	20	-	-	20	-	20	-	-
-	-	-	-	25	25	-	-	25	-	25	-	-
-	-	-	-	31.5	31.5	-	-	31.5	-	31.5	-	-
40	40	-	-	40	40	-	-	40	-	40	-	-
-	-	50	50	-	-	50	50	-	50	-	50	-
-	-	-	-	-	-	-	-	-	-	-	-	-
-	-	-	-	20	20	-	-	20	-	20	-	-
-	-	-	-	25	25	-	-	25	-	25	-	-
-	-	-	-	31.5	31.5	-	-	31.5	-	31.5	-	-
40	40	-	-	40	40	-	-	40	-	40	-	-
-	-	50	50	-	-	50	50	-	50	-	50	-
-	-	-	-	-	-	-	-	-	-	-	-	-
-	-	-	-	50	50	-	-	50	-	50	-	-
-	-	-	-	63	63	-	-	63	-	63	-	-
-	-	-	-	80	80	-	-	80	-	80	-	-
100	100	-	-	100	100	-	-	100	-	100	-	-
-	-	125	125	-	-	125	125	-	125	-	125	-
•	•	•	•	•	•	•	•	•	•	•	•	•
33 ... 60												
10 ... 15												
43 ... 75												
60 ... 80												
691	691	691	691	691	691	691	691	691	691	730	742	
653	853	681	853	653	853	681	853	853	853	853	853	853
641	642	643	643	642	642	643	643	640	643	640	643	643
210	275	210	275	210	275	210	275	275	275	275	275	275
174	176	180	193	160	166	190	205	186	225	221	240	240
-	-	-	-	7415	7416	-	-	7417	-	-	-	-
003284	003286	003444	003445	-	-	003444	003445	-	003446	000153	003447	
- 5 ... + 40												
•												
•												

СЕРВИС АУДИТОРА

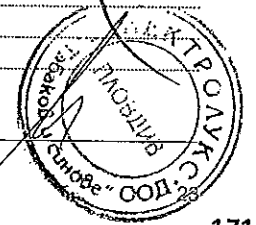

General characteristics of withdrawable circuit-breakers for UniGear ZS1 switchgear (17.5 kV)

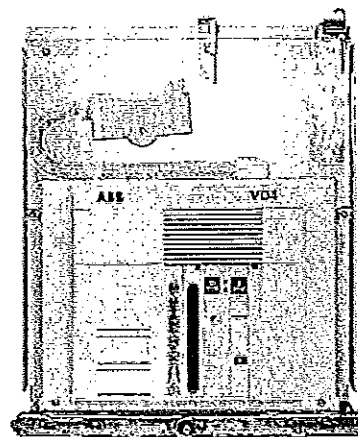

Circuit-breaker		VD4/P 17 (°)						
Standards	IEC 62271-100 VDE 0671; CEI EN 62271-100- File 7642	•						
Rated voltage	Ur [kV]	17.5						
Rated insulation voltage	Us [kV]	17.5						
Withstand voltage at 50 Hz	Ud (1 min) [kV]	38						
Impulse withstand voltage	Up [kV]	95						
Rated frequency	fr [Hz]	50-60						
Rated normal current (40 °C) (1)	Ir [A]	630	1250	1250	1250	1250	1600	1600
		16	16	-	-	-	-	-
Rated breaking capacity (rated short-circuit breaking current symmetrical)	Isc [kA]	20	20	-	-	-	20	20
		25	25	-	-	-	25	25
		31.5	31.5	-	-	-	31.5	31.5
		-	-	40	40	-	-	-
		-	-	-	-	50	-	-
Rated short-time withstand current (3s)	Ik [kA]	16	16	-	-	-	-	-
		20	20	-	-	-	20	20
		25	25	-	-	-	25	25
		31.5	31.5	-	-	-	31.5	31.5
		-	-	40	40	-	-	-
Breaking capacity	Ip [kA]	-	-	-	-	50	-	-
		40	40	-	-	-	-	-
		50	50	-	-	-	50	50
		63	63	-	-	-	63	63
		80	80	-	-	-	80	80
Operation sequence	[O - 0.3 s - CO - 15 s - CO]	•	•	•	•	•	•	•
Opening time	[ms]	33 ... 60						
Arcing time	[ms]	10 ... 15						
Total breaking time	[ms]	43 ... 75						
Closing time	[ms]	60 ... 80						
Maximum overall dimensions	H [mm]	632	632	691	691	691	691	691
	W [mm]	503	503	653	853	681	653	853
	D [mm]	664	664	641	642	643	642	642
	Pole distance P [mm]	150	150	210	275	210	210	275
Weight	[kg]	116	116	174	176	180	160	166
	TN	7412	7412	-	-	-	7415	7416
Standardised table of dimensions	1VCD	-	-	003284	003286	003444	-	-
Operating temperature	[°C]	- 5 ... + 40						
Tropicalization	IEC: 60068-2-30, 60721-2-1	•						
Electromagnetic compatibility	IEC: 62271-1	•						

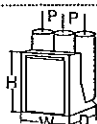

(1) Rated current guaranteed with circuit-breaker installed in UniGear ZS1 switchgear and with 40 °C ambient temperature.  
 (2) Up to 4000 A with forced ventilation.  
 (3) Circuit-breakers up to 1250 A and 31.5 kA have polyamide poles.

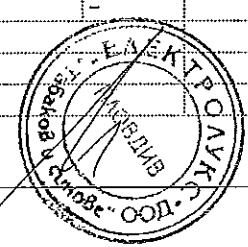

•												
•												
17.5												
17.5												
38												
95												
50-60												
1600	1600	1600	1600	2000	2000	2000	2000	2500	2500	3150 <sup>м</sup>	3150 <sup>м</sup>	
-	-	-	-	-	-	-	-	-	-	-	-	
-	-	-	-	20	20	-	-	20	-	20	-	
-	-	-	-	25	25	-	-	25	-	25	-	
-	-	-	-	31.5	31.5	-	-	31.5	-	31.5	-	
40	40	-	-	40	40	-	-	40	-	40	-	
-	-	50	50	-	-	50	50	-	50	-	50	
-	-	-	-	-	-	-	-	-	-	-	-	
-	-	-	-	20	20	-	-	20	-	20	-	
-	-	-	-	25	25	-	-	25	-	25	-	
-	-	-	-	31.5	31.5	-	-	31.5	-	31.5	-	
40	40	-	-	40	40	-	-	40	-	40	-	
-	-	50	50	-	-	50	50	-	50	-	50	
-	-	-	-	-	-	-	-	-	-	-	-	
-	-	-	-	50	50	-	-	50	-	50	-	
-	-	-	-	63	63	-	-	63	-	63	-	
-	-	-	-	80	80	-	-	80	-	80	-	
100	100	-	-	100	100	-	-	100	-	100	-	
-	-	125	125	-	-	125	125	-	125	-	125	
•	•	•	•	•	•	•	•	•	•	•	•	
33 ... 60												
10 ... 15												
43 ... 75												
60 ... 80												
691	691	691	691	691	691	691	691	691	691	730	742	
653	853	681	853	653	853	681	853	853	853	853	853	
641	642	643	643	642	642	643	643	640	643	640	643	
210	275	210	275	210	275	210	275	275	275	275	275	
174	176	180	193	160	166	190	205	186	225	221	240	
-	-	-	-	7415	7416	-	-	7417	-	-	-	
003284	003286	003444	003445	-	-	003444	003445	-	003446	000153	003447	
- 5 ... + 40												
•												
•												

РЕГИОНАЛЬНЫЙ ЦЕНТР

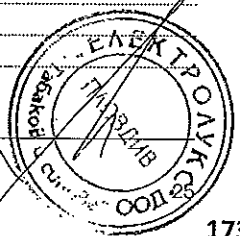

General characteristics of withdrawable circuit-breakers for UniGear ZS1 switchgear (24 kV)

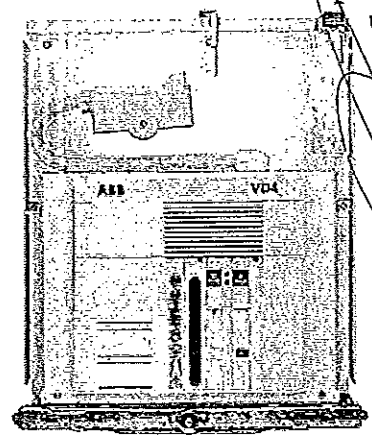

Circuit-breaker		VD4/P 24							
Standards		IEC 62271-100 •							
		VDE 0671; CEI EN 62271-100- File 7642 •							
Rated voltage	Ur [kV]	24							
Rated insulation voltage	Us [kV]	24							
Withstand voltage at 50 Hz	Ud (1 min) [kV]	50							
Impulse withstand voltage	Up [kV]	125							
Rated frequency	fr [Hz]	50-60							
Rated normal current (40 °C) <sup>(1)</sup>	Ir [A]	630	630	1250	1250	1600	2000	2500 <sup>(2)</sup>	3150 <sup>(3)</sup>
		16	16	16	16	16	16	16	—
Rated breaking capacity (rated short-circuit breaking current symmetrical)	Isc [kA]	20	20	20	20	20	20	20	—
		25	25	25	25	25	25	25	—
		—	—	31.5	—	31.5	31.5	31.5	31.5
Rated short-time withstand current (3s)	Ik [kA]	16	16	16	16	16	16	16	—
		20	20	20	20	20	20	20	—
		25	25	25	25	25	25	25	—
Making capacity	Ip [kA]	—	—	31.5	—	31.5	31.5	31.5	31.5
		40	40	40	40	40	40	40	—
		50	50	50	50	50	50	50	—
		63	63	63	63	63	63	63	—
		—	—	80	—	80	80	80	80
Operation sequence	[O - 0.3 s - CO - 15 s - CO]	•	•	•	•	•	•	•	•
Opening time	[ms]	33 ... 60							
Closing time	[ms]	10 ... 15							
Total breaking time	[ms]	43 ... 75							
Closing time	[ms]	60 ... 80							
Maximum overall dimensions	H [mm]	794	794	794	794	838	838	838	838
	W [mm]	653	653	653	653	653	653	653	653
	D [mm]	802	802	802	802	790	790	790	790
	Pole distance P [mm]	210	275	210	275	275	275	275	275
Weight	[kg]	140	148	140/146 <sup>(4)</sup>	148	228	228	228	277
Standardised table of dimensions	TN	7413	7414	7413	7414	7418	7418	7418	—
	1VCD	—	—	000173 <sup>(4)</sup>	—	—	—	—	000177
Operating temperature	[°C]	- 5 ... + 40							
Tropicalization		IEC: 60068-2-30, 60721-2-1 •							
Electromagnetic compatibility		IEC: 62271-1 •							

(1) Rated current guaranteed with circuit-breaker installed in UniGear ZS1 switchgear and with 40 °C ambient temperature.  
 (2) 2300 A rated current guaranteed with natural ventilation; 2500 A rated current guaranteed with forced ventilation.  
 (3) 2700 A rated current guaranteed with natural ventilation; 3150 A rated current guaranteed with forced ventilation.  
 (4) 31.5 kA version.

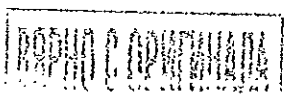

General characteristics of withdrawable circuit-breakers for UniGear ZS2 switchgear and PowerCube modules (36 kV)

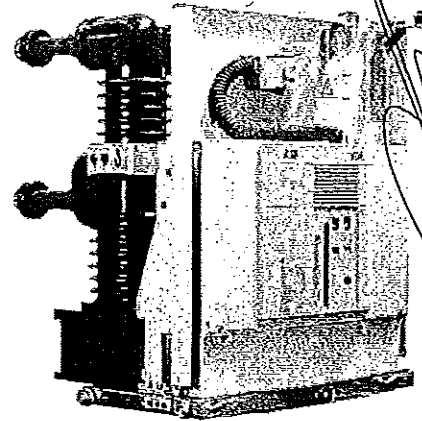

Circuit-breaker		VD4/W 36			
Standards	IEC 62271-100 • VDE 0671; CEI EN 62271-100- File 7642 •				
Rated voltage	Ur [kV]	36			
Rated insulation voltage	Us [kV]	36			
Withstand voltage at 50 Hz	Ud (1 min) [kV]	70			
Impulse withstand voltage	Up [kV]	170			
Rated frequency	fr [Hz]	50-60			
Rated normal current (40 °C) <sup>(*)</sup>	Ir [A]	1250	1600	2000	2500 <sup>(*)</sup>
Rated breaking capacity (rated short-circuit breaking current symmetrical)	Isc [kA]	—	—	—	—
		31.5	31.5	31.5	31.5
		—	—	—	—
Rated short-time withstand current (3s)	Ik [kA]	—	—	—	—
		31.5	31.5	31.5	31.5
		—	—	—	—
Making capacity	Ip [kA]	—	—	—	—
		80	80	80	80
		—	—	—	—
Operation sequence	[O - 0.3 s - CO - 15 s - CO]	•	•	•	•
Opening time	[ms]	33 ... 60			
Arcing time	[ms]	10 ... 15			
Total breaking time	[ms]	45 ... 75			
Closing time	[ms]	60 ... 80			
Maximum overall dimensions	H [mm]	973	973	973	973
	W [mm]	842	842	842	842
	D [mm]	788	788	788	788
	Pole distance P [mm]	275	275	275	275
Weight	[kg]	230	230	230	—
Standardised table of dimensions	TN	1VYN300901-KG	1VYN300901-KG	1VYN300901-KG	—
Operating temperature	[°C]	- 5 ... + 40			
Tropicalization	IEC: 60068-2-30, 60721-2-1	•			
Electromagnetic compatibility	IEC: 62271-1	•			

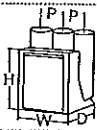

(\*) Ask ABB

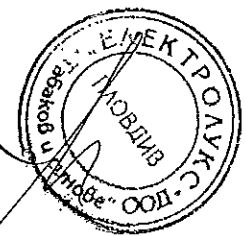
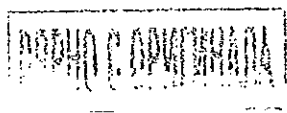



5.5.2. Types of withdrawable circuit-breakers available for UniGear ZS1 switchgear

VD4 withdrawable circuit-breaker (12 kV)

Ur	Isc	Rated uninterrupted current (40 °C) [A]					Circuit-breaker type
		W=650	W=800	W=1000	W=1000	W=1000	
kV	kA	P=150	P=210	P=275	P=275	P=275	
		u/l=205	u/l=310	u/l=310	u/l=310	u/l=310	
		ø=35	ø=79	ø=79	ø=109	ø=109	
12	16	630					VD4/P 12.06.16 p150
	20	630					VD4/P 12.06.20 p150
	25	630					VD4/P 12.06.25 p150
	31.5	630					VD4/P 12.06.32 p150
	16	1250					VD4/P 12.12.16 p150
	20	1250					VD4/P 12.12.20 p150
	25	1250					VD4/P 12.12.25 p150
	31.5	1250					VD4/P 12.12.32 p150
	40		1250				VD4/P 12.12.40 p210
	50		1250				VD4/P 12.12.50 p210
	20		1600				VD4/P 12.16.20 p210
	25		1600				VD4/P 12.16.25 p210
	31.5		1600				VD4/P 12.16.32 p210
	40		1600				VD4/P 12.16.40 p210
	50		1600				VD4/P 12.16.50 p210
	20		2000				VD4/P 12.20.20 p210
	25		2000				VD4/P 12.20.25 p210
	31.5		2000				VD4/P 12.20.32 p210
	40		2000				VD4/P 12.20.40 p210
	50		2000				VD4/P 12.20.50 p210
	40			1250			VD4/P 12.12.40 p275
	20			1600			VD4/P 12.16.20 p275
	25			1600			VD4/P 12.16.25 p275
	31.5			1600			VD4/P 12.16.32 p275
	40			1600			VD4/P 12.16.40 p275
	50			1600			VD4/P 12.16.50 p275
	20			2000			VD4/P 12.20.20 p275
	25			2000			VD4/P 12.20.25 p275
	31.5			2000			VD4/P 12.20.32 p275
	40			2000			VD4/P 12.20.40 p275
50			2000			VD4/P 12.20.50 p275	
20				2500		VD4/P 12.25.20 p275	
25				2500		VD4/P 12.25.25 p275	
31.5				2500		VD4/P 12.25.32 p275	
40				2500		VD4/P 12.25.40 p275	
50				2500		VD4/P 12.25.50 p275	
20					3150 (1)	VD4/P 12.32.20 p275	
25					3150 (1)	VD4/P 12.32.25 p275	
31.5					3150 (1)	VD4/P 12.32.32 p275	
40					3150 (1)	VD4/P 12.32.40 p275	
50					3150 (1)	VD4/P 12.32.50 p275	

W = Width of the circuit-breaker.  
 P = Pole horizontal centre distance.  
 u/l = Distance between bottom and top terminal.  
 ø = Diameter of the isolating contact.  
 (1) Up to 4000 A rated current guaranteed with forced ventilation.

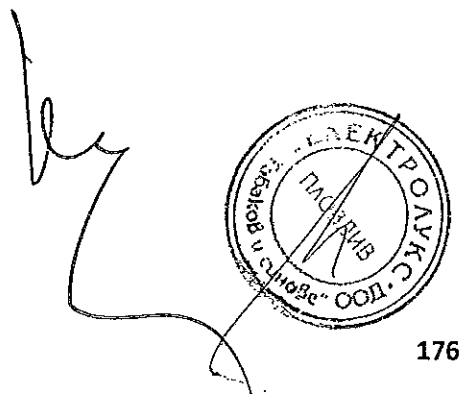
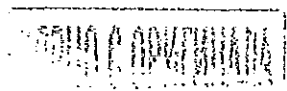

VD4 withdrawable circuit-breaker (17.5 kV)

Ur	Isc	Rated uninterrupted current (40 °C) [A]					Circuit-breaker type
		W=650 P=150 u/l=205 ø=35	W=800 P=210 u/l=310 ø=79	W=1000 P=275 u/l=310 ø=79	W=1000 P=275 u/l=310 ø=109	W=1000 P=275 u/l=310 ø=109	
16	630						VD4/P 17.06.16 p150
20	630						VD4/P 17.06.20 p150
25	630						VD4/P 17.06.25 p150
31.5	630						VD4/P 17.06.32 p150
16	1250						VD4/P 17.12.16 p150
20	1250						VD4/P 17.12.20 p150
25	1250						VD4/P 17.12.25 p150
31.5	1250						VD4/P 17.12.32 p150
40		1250					VD4/P 17.12.40 p210
50		1250					VD4/P 17.12.50 p210
20		1600					VD4/P 17.16.20 p210
25		1600					VD4/P 17.16.25 p210
31.5		1600					VD4/P 17.16.32 p210
40		1600					VD4/P 17.16.40 p210
50		1600					VD4/P 17.16.50 p210
20		2000					VD4/P 17.20.20 p210
25		2000					VD4/P 17.20.25 p210
31.5		2000					VD4/P 17.20.32 p210
40		2000					VD4/P 17.20.40 p210
50		2000					VD4/P 17.20.50 p210
17.5	40		1250				VD4/P 17.12.40 p275
20			1600				VD4/P 17.16.20 p275
25			1600				VD4/P 17.16.25 p275
31.5			1600				VD4/P 17.16.32 p275
40			1600				VD4/P 17.16.40 p275
50			1600				VD4/P 17.16.50 p275
20			2000				VD4/P 17.20.20 p275
25			2000				VD4/P 17.20.25 p275
31.5			2000				VD4/P 17.20.32 p275
40			2000				VD4/P 17.20.40 p275
50			2000				VD4/P 17.20.50 p275
20				2500			VD4/P 17.25.20 p275
25				2500			VD4/P 17.25.25 p275
31.5				2500			VD4/P 17.25.32 p275
40				2500			VD4/P 17.25.40 p275
50				2500			VD4/P 17.25.50 p275
20					3150 (1)		VD4/P 17.32.20 p275
25					3150 (1)		VD4/P 17.32.25 p275
31.5					3150 (1)		VD4/P 17.32.32 p275
40					3150 (1)		VD4/P 17.32.40 p275
50					3150 (1)		VD4/P 17.32.50 p275

W = Width of the circuit-breaker.

P = Pole horizontal centre distance.

u/l = Distance between bottom and top terminal.

ø = Diameter of the Isolating contact.

(1) Up to 4000 A rated current guaranteed with forced ventilation.

17.5



VD4 withdrawable circuit-breaker (24 kV)

Ur	Isc	Rated uninterrupted current (40 °C) [A]				Circuit-breaker type
		W=800	W=1000	W=1000	W=1000	
kV	kA	P=210	P=275	P=275	P=275	
		u/l=310	u/l=310	u/l=310	u/l=310	
		ø=35	ø=35	ø=79	ø=109	
24	16	630				VD4/P 24.06.16 p210
	20	630				VD4/P 24.06.20 p210
	25	630				VD4/P 24.06.25 p210
	16	1250				VD4/P 24.12.16 p210
	20	1250				VD4/P 24.12.20 p210
	25	1250				VD4/P 24.12.25 p210
	31.5	1250				VD4/P 24.12.32 p210
	16		630			VD4/P 24.06.16 p275
	20		630			VD4/P 24.06.20 p275
	25		630			VD4/P 24.06.25 p275
	16		1250			VD4/P 24.12.16 p275
	20		1250			VD4/P 24.12.20 p275
	25		1250			VD4/P 24.12.25 p275
	16			1600		VD4/P 24.16.16 p275
	20			1600		VD4/P 24.16.20 p275
	25			1600		VD4/P 24.16.25 p275
	31.5			1600		VD4/P 24.16.32 p275
	16			2000		VD4/P 24.20.16 p275
	20			2000		VD4/P 24.20.20 p275
	25			2000		VD4/P 24.20.25 p275
	31.5			2000		VD4/P 24.20.32 p275
	16			2300 <sup>(1)</sup>		VD4/P 24.25.16 p275
	20			2300 <sup>(1)</sup>		VD4/P 24.25.20 p275
	25			2300 <sup>(1)</sup>		VD4/P 24.25.25 p275
31.5			2300 <sup>(1)</sup>		VD4/P 24.25.32 p275	
31.5				2700 <sup>(2)</sup>	VD4/P 24.32.32 p275	

W = Width of the switchgear.  
 P = Pole horizontal centre distance.  
 u/l = Distance between bottom and top terminal.  
 ø = Diameter of the Isolating contact.  
 (1) 2500 A rated current guaranteed with forced ventilation.  
 (2) 3150 A rated current guaranteed with forced ventilation.

VD4 withdrawable circuit-breaker (36 kV)

Ur	Isc	Rated uninterrupted current (40 °C) [A]		Circuit-breaker type
		H=951	D=788	
kV	kA	u/l=380		
		ø=399		
		P=275		
		W=778		
36	31.5	1250 A		VD4/W 36.12.32 p275
		1600 A		VD4/W 36.16.32 p275
		2000 A		VD4/W 36.20.32 p275
		2500 A <sup>(1)</sup>		VD4/W 36.25.32 p275

H = Height of the circuit-breaker.  
 D = Depth of the circuit-breaker.  
 u/l = Distance between bottom and top terminal.  
 ø = Diameter of the Isolating contact.  
 P = Pole horizontal centre distance.  
 W = Width of the circuit-breaker.  
 (\*) = To be released. Contact ABB

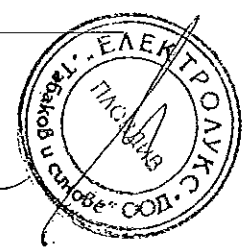
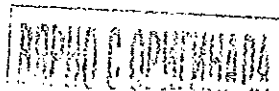

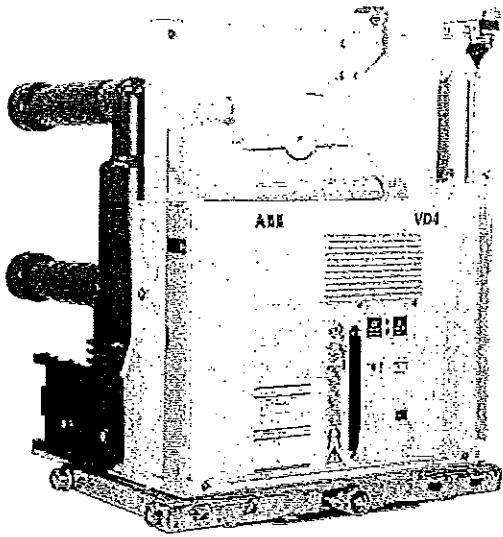

VD4 - up to 24 kV

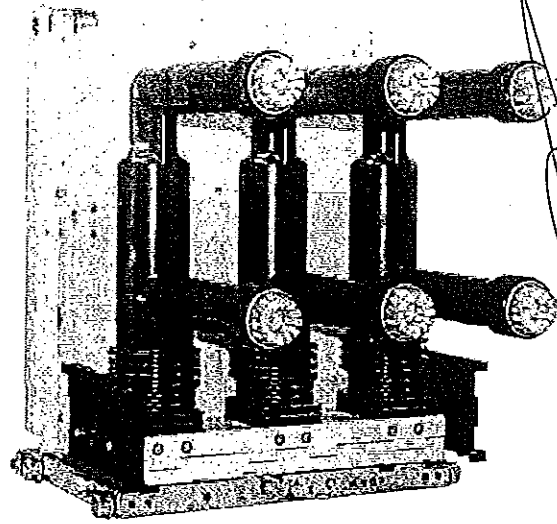

VD4 - up to 24 kV

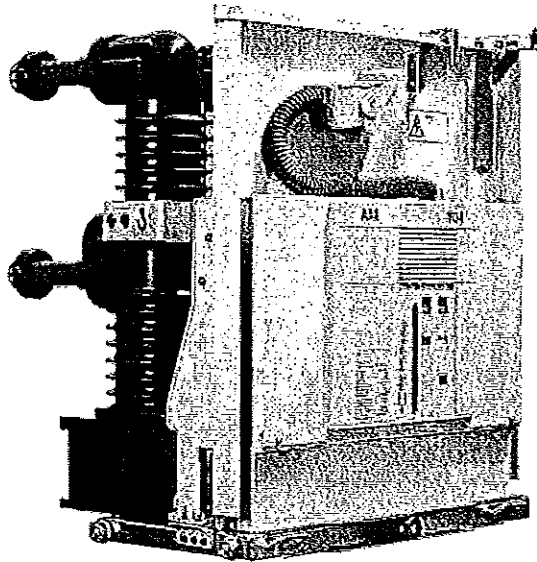

VD4 - 36 kV

**5.5.3. Standard fittings of withdrawable circuit-breakers for UniGear ZS1 switchgear (up to 24 kV) - UniGear ZS2 and PowerCube modules (VD4 36 kV)**

The basic versions of the withdrawable circuit-breakers are three-pole and fitted with:

- EL type manual operating mechanism
- mechanical signalling device for closing spring charged/ discharged
- mechanical signalling device for circuit-breaker open/closed
- closing pushbutton
- opening pushbutton
- operation counter
- set of ten auxiliary circuit-breaker open/closed contacts

Note: with the set of ten auxiliary contacts supplied as standard and the maximum number of electrical applications possible, three make contacts (signalling circuit-breaker open) and four break contacts (signalling circuit-breaker closed) are available.

- lever for manually charging the closing spring
- isolating contacts
- cord with connector (plug only) for auxiliary circuits, with striker pin which does not allow connection of the plug in the socket if the rated current of the circuit-breaker is different from the rated current of the panel
- racking-in/out lever (the quantity must be defined according to the number of pieces of apparatus ordered)
- locking electromagnet in the truck. This prevents the circuit-breaker from being racked into the panel with auxiliary circuits not connected (plug not inserted in the socket).

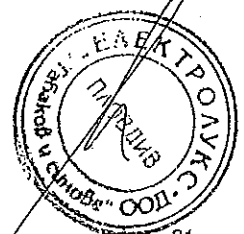
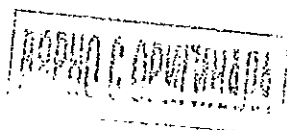

5.5.4. General characteristics of withdrawable circuit-breakers for PowerCube modules

General characteristics of withdrawable circuit-breakers for PowerCube modules (12 kV)

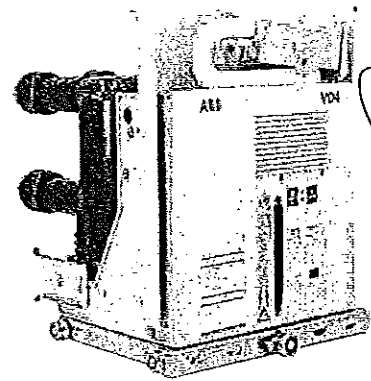

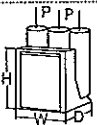
Circuit-breaker	VD4/P 12 (*)		VD4/W 12 (*)			
	PowerCube module	PB1	PB2			
Standards	IEC 62271-100 • VDE 0671; CEI EN 62271-100- File 7642 •					
Rated voltage	Ur [kV]	12	12			
Rated insulation voltage	Us [kV]	12	12			
Withstand voltage at 50 Hz	Ud (1 min) [kV]	28	28			
Impulse withstand voltage	Up [kV]	75	75			
Rated frequency	fr [Hz]	50-60	50-60			
Rated normal current (40 °C) (1)	Ir [A]	630	1250	630	1250	
		16	16	16	16	
		20	20	20	20	
		25	25	25	25	
		31.5	31.5	31.5	31.5	
Rated breaking capacity (rated short-circuit breaking current symmetrical)	Isc [kA]	-	-	-	-	
		-	-	-	-	
		16	16	16	16	
		20	20	20	20	
		25	25	25	25	
Rated short-time withstand current (3s)	Ik [kA]	31.5	31.5	31.5	31.5	
		-	-	-	-	
		-	-	-	-	
		16	16	16	16	
		20	20	20	20	
Rated making capacity	Ip [kA]	25	25	25	25	
		31.5	31.5	31.5	31.5	
		-	-	-	-	
		40	40	40	40	
		50	50	50	50	
Opening sequence	[O - 0.3 s - CO - 15 s - CO]	63	63	63	63	
		80	80	80	80	
		-	-	-	-	
		-	-	-	-	
		-	-	-	-	
Operation sequence	[O - 0.3 s - CO - 15 s - CO]	•	•	•	•	
		•	•	•	•	
		•	•	•	•	
		•	•	•	•	
		•	•	•	•	
Opening time	[ms]	33 ... 60	33 ... 60	33 ... 60	33 ... 60	
		10 ... 15	10 ... 15	10 ... 15	10 ... 15	
		43 ... 75	43 ... 75	43 ... 75	43 ... 75	
		60 ... 80	60 ... 80	60 ... 80	60 ... 80	
		60 ... 80	60 ... 80	60 ... 80	60 ... 80	
Arcing time	[ms]	33 ... 60	33 ... 60	33 ... 60	33 ... 60	
		10 ... 15	10 ... 15	10 ... 15	10 ... 15	
		43 ... 75	43 ... 75	43 ... 75	43 ... 75	
		60 ... 80	60 ... 80	60 ... 80	60 ... 80	
		60 ... 80	60 ... 80	60 ... 80	60 ... 80	
Total breaking time	[ms]	33 ... 60	33 ... 60	33 ... 60	33 ... 60	
		10 ... 15	10 ... 15	10 ... 15	10 ... 15	
		43 ... 75	43 ... 75	43 ... 75	43 ... 75	
		60 ... 80	60 ... 80	60 ... 80	60 ... 80	
		60 ... 80	60 ... 80	60 ... 80	60 ... 80	
Closing time	[ms]	33 ... 60	33 ... 60	33 ... 60	33 ... 60	
		10 ... 15	10 ... 15	10 ... 15	10 ... 15	
		43 ... 75	43 ... 75	43 ... 75	43 ... 75	
		60 ... 80	60 ... 80	60 ... 80	60 ... 80	
		60 ... 80	60 ... 80	60 ... 80	60 ... 80	
Maximum overall dimensions		H [mm]	628	628	691	691
		W [mm]	503	503	653	853
		D [mm]	662	662	642	642
		Pole distance P [mm]	150	150	210	210
		Weight	[kg]	116	116	135
Standardised table of dimensions	TN	7412	7412	7420	7420	
	1VCD	-	-	-	-	
Operating temperature	[°C]	- 5 ... + 40	- 5 ... + 40	- 5 ... + 40	- 5 ... + 40	
Tropicalization	IEC: 60068-2-30, 60721-2-1	•	•	•	•	
Electromagnetic compatibility	IEC: 62271-1	•	•	•	•	

(1) Rated current guaranteed with circuit-breaker installed in PowerCube enclosure and with 40 °C ambient temperature  
 (2) Up to 4000 A with forced ventilation.  
 (3) Circuit-breakers up to 1250 A and 31.5 kA have polyamide poles.

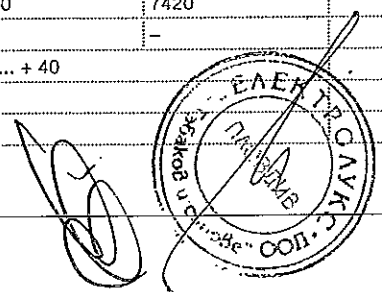
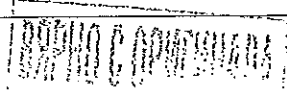

VD4/P 12								VD4/W 12			
PB2								PB3		PB3	
•								•		•	
•								•		•	
12								12		12	
12								12		12	
28								28		28	
75								75		75	
50-60								50-60		50-60	
1250	1250	1600	1600	1600	2000	2000	2500	2500	3150	3150	3150
-	-	-	-	-	-	-	-	-	-	-	-
-	-	20	-	-	20	-	20	-	20	-	-
-	-	25	-	-	25	-	25	-	25	-	-
-	-	31.5	-	-	31.5	-	31.5	-	31.5	-	-
40	-	-	40	-	40	-	40	-	40	-	-
-	60	-	-	50	-	50	-	50	-	-	50
-	-	-	-	-	-	-	-	-	-	-	-
-	-	20	-	-	20	-	20	-	20	-	-
-	-	25	-	-	25	-	25	-	25	-	-
-	-	31.5	-	-	31.5	-	31.5	-	31.5	-	-
40	-	-	40	-	40	-	40	-	40	-	-
-	60	-	-	50	-	50	-	50	-	-	50
-	-	-	-	-	-	-	-	-	-	-	-
-	-	50	-	-	50	-	50	-	50	-	-
-	-	63	-	-	63	-	63	-	63	-	-
-	-	80	-	-	80	-	80	-	80	-	-
100	-	-	100	-	100	-	100	-	100	-	-
-	125	-	-	125	-	125	-	125	-	-	125
•								•		•	
33 ... 60								33 ... 60		33 ... 60	
10 ... 15								10 ... 15		10 ... 15	
43 ... 75								43 ... 75		43 ... 75	
60 ... 80								60 ... 80		60 ... 80	
691	691	691	691	691	690	691	691	691	730	691	
653	681	653	653	681	653	681	653	653	853	853	853
641	643	642	641	643	642	643	640	643	640	643	643
210	210	210	210	210	210	210	275	275	275	275	275
174	180	160	174	180	160	190	186	225	221	240	240
-	-	7415	-	-	7415	-	7417	-	-	-	-
003284	003444	-	003284	003444	-	003444	-	003445	000152	003596	
- 5 ... + 40								- 5 ... + 40	- 5 ... + 40		
•								•		•	
•								•		•	

ИЗДАНИЕ 1991 ГОДА

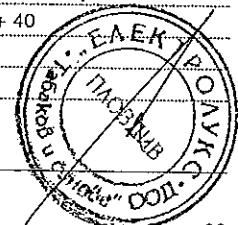

General characteristics of withdrawable circuit-breakers for PowerCube modules (17.5 kV)

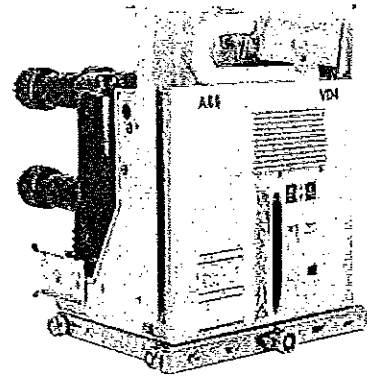

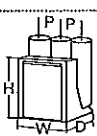
Circuit-breaker	VD4/P 17 (°)		VD4/W 17 (°)			
	PowerCube module	PB1	PB2			
Standards	IEC 62271-100 VDE 0671; CEI EN 62271-100- File 7642	•	•			
Rated voltage	Ur [kV]	17.5	17.5			
Rated insulation voltage	Us [kV]	17.5	17.5			
Withstand voltage at 50 Hz	Ud (1 min) [kV]	38	38			
Impulse withstand voltage	Up [kV]	95	95			
Rated frequency	fr [Hz]	50-60	50-60			
Rated normal current (40 °C) (1)	Ir [A]	630	1250	630	1250	
		16	16	16	16	
		20	20	20	20	
		25	25	25	25	
		31.5	31.5	31.5	31.5	
		-	-	-	-	
Rated breaking capacity (rated short-circuit breaking current symmetrical)	Isc [kA]	16	16	16	16	
		20	20	20	20	
		25	25	25	25	
		31.5	31.5	31.5	31.5	
		-	-	-	-	
		-	-	-	-	
Rated short-time withstand current (3s)	Ik [kA]	16	16	16	16	
		20	20	20	20	
		25	25	25	25	
		31.5	31.5	31.5	31.5	
		-	-	-	-	
		-	-	-	-	
Rated making capacity	Ip [kA]	40	40	40	40	
		50	50	50	50	
		63	63	63	63	
		80	80	80	80	
		-	-	-	-	
		-	-	-	-	
Operation sequence	[O - 0.3 s - CO - 15 s - CO]	•	•			
Opening time	[ms]	33 ... 60	33 ... 60			
Arcing time	[ms]	10 ... 15	10 ... 15			
Total breaking time	[ms]	43 ... 75	43 ... 75			
Closing time	[ms]	60 ... 80	60 ... 80			
Maximum overall dimensions		H [mm]	628	628	691	691
		W [mm]	503	503	503	853
		D [mm]	662	662	642	642
		Pole distance P [mm]	150	150	210	210
Weight	[kg]	116	116	135	135	
Standardised table of dimensions	TN	7412	7412	7420	7420	
Operating temperature	[°C]	- 5 ... + 40	- 5 ... + 40	- 5 ... + 40	- 5 ... + 40	
Tropicalization	IEC: 60068-2-30, 60721-2-1	•	•			
Electromagnetic compatibility	IEC: 62271-1	•	•			

(1) Rated current guaranteed with circuit-breaker installed in PowerCube enclosure and with 40 °C ambient temperature.  
 (2) Up to 4000 A with forced ventilation.  
 (3) Circuit-breakers up to 1250 A and 31.5 kA have polyamide poles.

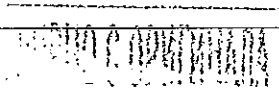

VD4/P 17							VD4/W 17				
PB2							PB3		PB3		
•							•			•	
•							•			•	
17.5							17.5			17.5	
17.5							17.5			17.5	
38							38			38	
95							95			95	
50-60							50-60			50-60	
1250	1250	1600	1600	1600	2000	2000	2500	2500	3150	3150	
-	-	-	-	-	-	-	-	-	-	-	-
-	-	20	-	-	20	-	20	-	-	20	-
-	-	25	-	-	25	-	25	-	-	25	-
-	-	31.5	-	-	31.5	-	31.5	-	-	31.5	-
40	-	-	40	-	40	-	40	-	-	40	-
-	50	-	-	50	-	50	-	50	50	-	-
-	-	-	-	-	-	-	-	-	-	-	-
-	-	20	-	-	20	-	20	-	-	20	-
-	-	25	-	-	25	-	25	-	-	25	-
-	-	31.5	-	-	31.5	-	31.5	-	-	31.5	-
40	-	-	40	-	40	-	40	-	-	40	-
-	50	-	-	50	-	50	-	50	50	-	-
-	-	-	-	-	-	-	-	-	-	-	-
-	-	50	-	-	50	-	50	-	-	50	-
-	-	63	-	-	63	-	63	-	-	63	-
-	-	80	-	-	80	-	80	-	-	80	-
100	-	-	100	-	100	-	100	-	-	100	-
-	125	-	-	125	-	125	-	125	125	-	-
•							•			•	
33 ... 60							33 ... 60			33 ... 60	
10 ... 15							10 ... 15			10 ... 15	
43 ... 75							43 ... 75			43 ... 75	
60 ... 80							60 ... 80			60 ... 80	
691	691	691	691	691	690	691	691	691	691	730	
653	681	653	653	681	653	681	853	853	853	853	
641	643	642	641	643	642	643	640	643	643	640	
210	210	210	210	210	210	210	275	275	275	275	
174	180	160	174	180	160	190	186	225	240	221	
-	-	7415	-	-	7415	-	7417	-	-	-	
003284	003444	-	003284	003444	-	003444	-	003445	003596	000152	
- 5 ... + 40							- 5 ... + 40		- 5 ... + 40		
•							•			•	
•							•			•	

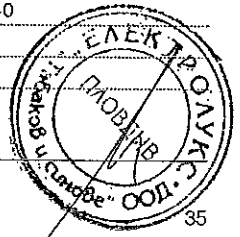
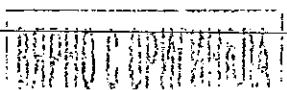



General characteristics of withdrawable circuit-breakers for PowerCube modules (24 kV)

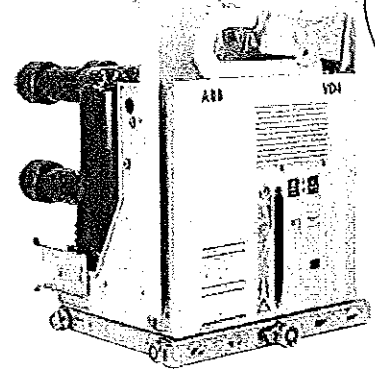

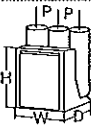
Circuit-breaker	VD4/P 24						
	PowerCube module	PB4		PB5			
Standards	IEC 62271-100	•		•			
	VDE 0671; CEI EN 62271-100- File 7642	•		•			
Rated voltage	Ur [kV]	24		24			
Rated insulation voltage	Us [kV]	24		24			
Withstand voltage at 50 Hz	Ud (1 min) [kV]	50		50			
Impulse withstand voltage	Up [kV]	125		125			
Rated frequency	fr [Hz]	50-60		50-60			
Rated normal current (40 °C) <sup>(1)</sup>	Ir [A]	630	1250	1600	2000	2500 <sup>(2)</sup>	
		16	16	16	16	16	
Rated breaking capacity (rated short-circuit breaking current symmetrical)	Isc [kA]	20	20	20	20	20	
		25	25	25	25	25	
		–	31,5	31,5	31,5	31,5	
		16	16	16	16	16	
		20	20	20	20	20	
Rated short-time withstand current (3s)	Ik [kA]	25	25	25	25	25	
		–	31,5	31,5	31,5	31,5	
		40	40	40	40	40	
Making capacity	Ip [kA]	50	50	50	50	50	
		63	63	63	63	63	
		–	80	80	80	80	
Operation sequence	[O - 0.3 s - CO - 15 s - CO]	•		•			
Opening time	[ms]	33 ... 60		33 ... 60			
Closing time	[ms]	10 ... 15		10 ... 15			
Total breaking time	[ms]	43 ... 75		43 ... 75			
Closing time	[ms]	60 ... 80		60 ... 80			
Maximum overall dimensions		H [mm]	794	794	838	838	838
		W [mm]	653	653	853	853	853
		D [mm]	802	802	790	790	790
		Pole distance P [mm]	210	210	275	275	275
Weight	[kg]	140	140/146 <sup>(3)</sup>	228	228	228	
Standardised table of dimensions	TN	7413	7413	7418	7418	7418	
	1VCD	–	000173 <sup>(3)</sup>	–	–	–	
Operating temperature	[°C]	- 5 ... + 40					
Tropicalization	IEC: 60068-2-30, 60721-2-1	•					
Electromagnetic compatibility	IEC: 62271-1	•					

(1) Rated current guaranteed with circuit-breaker installed in PowerCube enclosure and with 40 °C ambient temperature.  
 (2) 2300 A rated uninterrupted current guaranteed with natural ventilation; 2500 A rated current guaranteed with forced ventilation.  
 (3) 31.5 kA version.

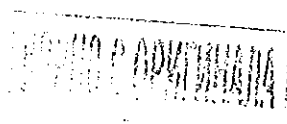

5.5.5. Types of withdrawable circuit-breakers available for PowerCube modules

VD4 withdrawable circuit-breaker (12 kV)

Ur	Isc	Rated uninterrupted current (40 °C) [A]					Circuit-breaker type
		W=650 P=150 u/l=205 ø=35	W=800 P=210 u/l=310 ø=79	W=1000 P=275 u/l=310 ø=79	W=1000 P=275 u/l=310 ø=109	W=1000 P=275 u/l=310 ø=109	
16	630						VD4/P 12.06.16 p150
20	630						VD4/P 12.06.20 p150
25	630						VD4/P 12.06.25 p150
31.5	630						VD4/P 12.06.32 p150
16	1250						VD4/P 12.12.16 p150
20	1250						VD4/P 12.12.20 p150
25	1250						VD4/P 12.12.25 p150
31.5	1250						VD4/P 12.12.32 p150
16		630					VD4/W 12.06.16 p210
20		630					VD4/W 12.06.20 p210
25		630					VD4/W 12.06.25 p210
31.5		630					VD4/W 12.06.32 p210
16		1250					VD4/W 12.12.16 p210
20		1250					VD4/W 12.12.20 p210
25		1250					VD4/W 12.12.25 p210
31.5		1250					VD4/W 12.12.32 p210
40		1250					VD4/P 12.12.40 p210
50		1250					VD4/P 12.12.50 p210
20			1600				VD4/P 12.16.20 p210
25			1600				VD4/P 12.16.25 p210
31.5			1600				VD4/P 12.16.32 p210
40			1600				VD4/P 12.16.40 p210
50			1600				VD4/P 12.16.50 p210
20			2000				VD4/P 12.20.20 p210
25			2000				VD4/P 12.20.25 p210
31.5			2000				VD4/P 12.20.32 p210
40			2000				VD4/P 12.20.40 p210
50			2000				VD4/P 12.20.50 p210
20				2500			VD4/P 12.25.20 p275
25				2500			VD4/P 12.25.25 p275
31.5				2500			VD4/P 12.25.32 p275
40				2500			VD4/P 12.25.40 p275
50				2500			VD4/P 12.25.50 p275
20					3150 (1)		VD4/W 12.32.20 p275
25					3150 (1)		VD4/W 12.32.25 p275
31.5					3150 (1)		VD4/W 12.32.32 p275
40					3150 (1)		VD4/W 12.32.40 p275
50					3150 (1)		VD4/W 12.32.50 p275

W = Width of the switchgear.  
P = Pole horizontal centre distance.  
u/l = Distance between bottom and top terminal.  
ø = Diameter of the isolating contact.  
(1) Up to 4000 A rated current guaranteed with forced ventilation. Available on request.

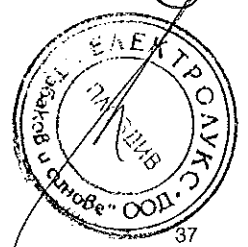
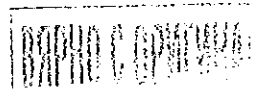

VD4 withdrawable circuit-breaker (17.5 kV)

Ur	Isc	Rated uninterrupted current (40 °C) [A]					Circuit-breaker type
		W=650 P=150 u/l=205 ø=35	W=800 P=210 u/l=310 ø=79	W=1000 P=275 u/l=310 ø=79	W=1000 P=275 u/l=310 ø=109	W=1000 P=275 u/l=310 ø=109	
17.5	16	630					VD4/P 17.06.16 p150
		630					VD4/P 17.06.20 p150
		630					VD4/P 17.06.25 p150
		630					VD4/P 17.06.32 p150
		1250					VD4/P 17.12.16 p150
	20	1250					VD4/P 17.12.20 p150
		1250					VD4/P 17.12.25 p150
		1250					VD4/P 17.12.32 p150
		630					VD4/W 17.06.16 p210
		630					VD4/W 17.06.20 p210
	25	630					VD4/W 17.06.25 p210
		630					VD4/W 17.06.32 p210
		1250					VD4/W 17.12.16 p210
		1250					VD4/W 17.12.20 p210
		1250					VD4/W 17.12.25 p210
	31.5	1250					VD4/W 17.12.32 p210
		1250					VD4/P 17.12.40 p210
		1250					VD4/P 17.12.50 p210
		1600					VD4/P 17.16.20 p210
		1600					VD4/P 17.16.25 p210
40	1600					VD4/P 17.16.32 p210	
	1600					VD4/P 17.16.40 p210	
	1600					VD4/P 17.16.50 p210	
	2000					VD4/P 17.20.20 p210	
	2000					VD4/P 17.20.25 p210	
50	2000					VD4/P 17.20.32 p210	
	2000					VD4/P 17.20.40 p210	
	2000					VD4/P 17.20.50 p210	
	2500					VD4/P 17.25.20 p275	
	2500					VD4/P 17.25.25 p275	
3150 <sup>(1)</sup>	2500					VD4/P 17.25.32 p275	
	2500					VD4/P 17.25.40 p275	
	2500					VD4/P 17.25.50 p275	
	3150 <sup>(1)</sup>					VD4/W 17.32.20 p275	
	3150 <sup>(1)</sup>					VD4/W 17.32.25 p275	
3150 <sup>(1)</sup>	3150 <sup>(1)</sup>					VD4/W 17.32.32 p275	
	3150 <sup>(1)</sup>					VD4/W 17.32.40 p275	
	3150 <sup>(1)</sup>					VD4/W 17.32.50 p275	

W = Width of the switchgear.  
 P = Pole horizontal centre distance.  
 u/l = Distance between bottom and top terminal.  
 ø = Diameter of the isolating contact.  
 (1) Up to 4000 A rated current guaranteed with forced ventilation. Available on request.

РАДИО С ОБОЗНАЧЕНИЕМ

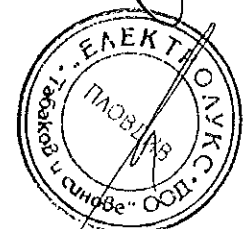

## VD4 withdrawable circuit-breaker (24 kV)

Ur	Isc	Rated uninterrupted current (40 °C) [A]		Circuit-breaker type
		W=800	W=1000	
kV	kA	P=210	P=275	
		u/l=310	u/l=310	
		ø=35	ø=79	
24	16	630		VD4/P 24.06.16 p210
	20	630		VD4/P 24.06.20 p210
	25	630		VD4/P 24.06.25 p210
	16	1250		VD4/P 24.12.16 p210
	20	1250		VD4/P 24.12.20 p210
	25	1250		VD4/P 24.12.25 p210
	31.5	1250		VD4/P 24.12.32 p210
	16		1600	VD4/P 24.16.16 p275
	20		1600	VD4/P 24.16.20 p275
	25		1600	VD4/P 24.16.25 p275
	31.5		1600	VD4/P 24.16.32 p275
	16		2000	VD4/P 24.20.16 p275
	20		2000	VD4/P 24.20.20 p275
	25		2000	VD4/P 24.20.25 p275
	31.5		2000	VD4/P 24.20.32 p275
	16		2300 <sup>(1)</sup>	VD4/P 24.25.16 p275
	20		2300 <sup>(1)</sup>	VD4/P 24.25.20 p275
	25		2300 <sup>(1)</sup>	VD4/P 24.25.25 p275
	31.5		2300 <sup>(1)</sup>	VD4/P 24.25.32 p275

W = Width of the switchgear.

P = Pole horizontal centre distance.

u/l = Distance between bottom and top terminal.

ø = Diameter of the isolating contact.

(1) Up to 2500 A rated current guaranteed with forced ventilation.

### 5.5.6. Standard fittings for withdrawable circuit-breakers for PowerCube modules

The basic versions of the withdrawable circuit-breakers are always three-pole and fitted with:

- EL type manual operating mechanism
- mechanical signalling device for closing spring charged/discharged
- mechanical signalling device for circuit-breaker open/closed
- closing pushbutton
- opening pushbutton
- operation counter
- set of ten auxiliary circuit-breaker open/closed contacts  
Note: with the group of ten auxiliary contacts supplied as standard and the maximum number of electrical applications, three make contacts (signalling circuit-breaker open) and four break contacts (signalling circuit-breaker closed) are available.
- lever for manually charging the closing spring
- isolating contacts
- cord with connector (only plug) for auxiliary circuits, with striker pin which does not allow connection of the plug in the socket if the rated current of the circuit-breaker is different from the rated current of the panel
- racking-in/out lever (the quantity must be defined according to the number of pieces of apparatus ordered)
- locking electromagnet in the truck. This prevents racking-in of the circuit-breaker in the panel with auxiliary circuits not connected (plug not inserted in the socket).

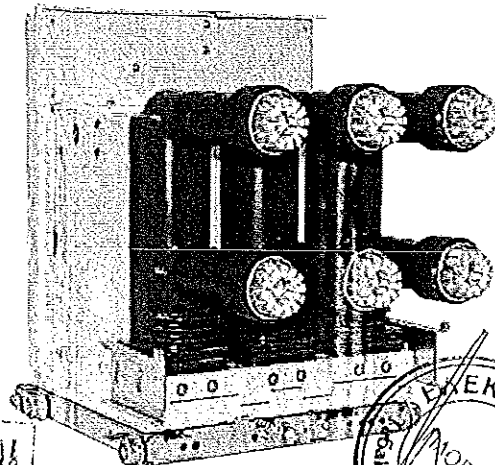
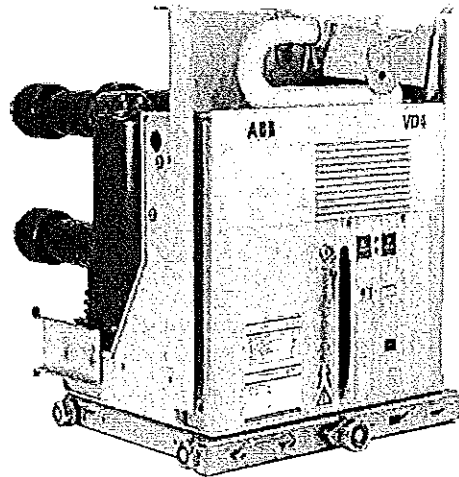

РАДИО С ОПРЕДЕЛЕНИЕМ

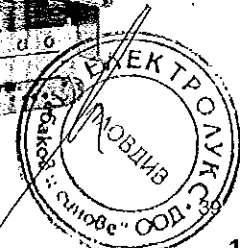

5.5.7. General characteristics of withdrawable circuit-breakers for ZS8.4 switchgear

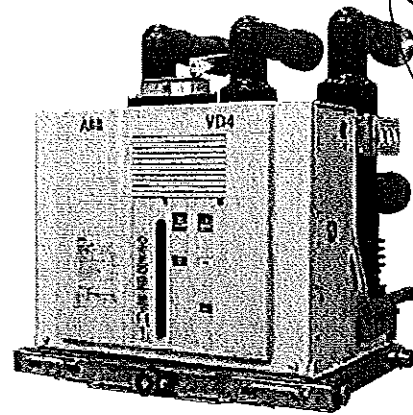

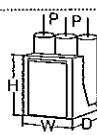
Circuit-breaker		VD4/Z8						
	Panel without partitions	•						
	Panel with partitions	-						
	Preussen Elektra - EON	-						
	Width [kV]	650	650	650	650	800	800	
	Depth [kV]	1000	1000	1000	1000	1200	1200	
Standards	IEC 62271-100	•						
	VDE 0671	•						
Rated voltage	Ur [kV]	12	12	17.5	17.5	24	24	
Rated insulation voltage	Us [kV]	12	12	17.5	17.5	24	24	
Withstand voltage at 50 Hz	Ud (1 min) [kV]	28	28	38	38	50	50	
Impulse withstand voltage	Up [kV]	75	75	95	95	125	125	
Rated frequency	fr [Hz]	50-60						
Rated normal current (40 °C) <sup>(1)</sup>	Ir [A]	630	1250	630	1250	630	1250	
Rated breaking capacity (rated symmetrical short-circuit current)	Isc [kA]	-	-	-	-	16	16	
		20	20	20	20	20	20	
		25	25	25	25	25	25	
Rated short-time withstand current (3 s)	Ik [kA]	-	-	-	-	16	16	
		20	20	20	20	20	20	
		25	25	25	25	25	25	
Making capacity	Ip [kA]	18,5 mm	50	50	50	50	50	
		63	63	63	63	63	63	
Operation sequence	[O-0.3s-CO-15s-CO]	•						
Opening time	[ms]	33...60						
Arcing time	[ms]	10...15						
Total breaking time	[ms]	43...75						
Closing time	[ms]	60...80						
Maximum overall dimensions		H [mm]	579	579	579	579	680	680
		W [mm]	503	503	503	503	653	653
		D [mm]	548	548	548	548	646	646
		Pole distance P [mm]	150	150	150	150	210	210
Weight	[kg]	116	116	116	116	140	140	
Standardised table of dimensions	1VCD	000092	000137	000137	000137	000089	000138	
Operating temperature	[°C]	- 5 ... + 40						
Tropicalisation	IEC 60068-2-30	•						
	IEC 60721-2-1	•						
Electromagnetic compatibility	IEC 62271-1	•						

(1) Rated current guaranteed with circuit-breaker installed in switchgear with 40 °C ambient temperature.  
 (2) Special type with device for charging the closing spring by means of a rotary handle outside the operating mechanism.



VD4/ZT8						VD4/ZS8			
-						-			
•						•			
•						•			
650	650	650	650	800	800	650	650	800	800
1200	1200	1200	1200	1200	1200	1200	1200	1200	1200
•						•			
•						•			
12	12	17.5	17.5	24	24	12	12	24	24
12	12	17.5	17.5	24	24	12	12	24	24
28	28	38	38	50	50	28	28	50	50
75	75	95	95	125	125	75	75	125	125
50-60						50-60			
630	1250	630	1250	630	1250	630	1250	630	1250
-	-	-	-	16	16	-	-	16	16
20	20	20	20	20	20	20	20	20	20
25	25	25	25	25	25	25	25	25	25
-	-	-	-	16	16	-	-	16	16
20	20	20	20	20	20	20	20	20	20
25	25	25	25	25	25	25	25	25	25
-	-	-	-	40	40	-	-	40	40
50	50	50	50	50	50	50	50	50	50
63	63	63	63	63	63	63	63	63	63
•						•			
33...60						40...60			
10...15						10...15			
43...75						50...75			
60...80						60...80			
579	579	579	579	680	680	579	579	680	680
503	503	503	503	653	653	503	503	653	653
638	638	638	638	646	646	638	638	646	646
150	150	150	150	210	210	150	150	210	210
116	116	116	116	140	140	116	116	140	140
000093	000134	000134	000134	000090	000136	00009	000133	000088	000135
- 5 ... + 40						- 5 ... + 40			
•						•			
•						•			
•						•			

ПРОМО С ОПРЕДЕЛЕНИЕ



5.5.8. General characteristics of withdrawable circuit-breakers for ZS8.4 switchgear

VD4/ZS8 - VD4/ZT8 - VD4/Z8 withdrawable circuit-breaker for ZS8.4 switchgear

Ur	Isc	Rated uninterrupted current (40 °C) [A]						Circuit-breaker type	
		Panel without partition		Panel with partition		Special panel EON			
		W = 650	W = 800	W = 650	W = 800	W = 650	W = 800		
		P = 150	P = 210	P = 150	P = 210	P = 150	P = 210		
kV	kA	u/l = 205	u/l = 310	u/l = 205	u/l = 310	u/l = 205	u/l = 310		
		ø = 35	ø = 35	ø = 35	ø = 35	ø = 35	ø = 35		
		20	630					VD4/Z8 12.06.20 p150	
		25	630					VD4/Z8 12.06.25 p150	
12	20	1250						VD4/Z8 12.12.20 p150	
	25	1250						VD4/Z8 12.12.25 p150	
	20			630				VD4/ZT8 12.06.20 p150	
	25			630				VD4/ZT8 12.06.25 p150	
	20			1250				VD4/ZT8 12.12.20 p150	
	25			1250				VD4/ZT8 12.12.25 p150	
	20					630		VD4/ZS8 12.06.20 p150	
	25					630		VD4/ZS8 12.06.25 p150	
	20					1250		VD4/ZS8 12.12.20 p150	
	25					1250		VD4/ZS8 12.12.25 p150	
	17.5	20	630						VD4/Z8 17.06.20 p150
		25	630						VD4/Z8 17.06.25 p150
20		1250						VD4/Z8 17.12.20 p150	
25		1250						VD4/Z8 17.12.25 p150	
20				630				VD4/ZT8 17.06.20 p150	
25				630				VD4/ZT8 17.06.25 p150	
20				1250				VD4/ZT8 17.12.20 p150	
25				1250				VD4/ZT8 17.12.25 p150	
24	16		630					VD4/Z8 24.06.16 p210	
	20		630					VD4/Z8 24.06.20 p210	
	25		630					VD4/Z8 24.06.25 p210	
	16		1250					VD4/Z8 24.12.16 p210	
	20		1250					VD4/Z8 24.12.20 p210	
	25		1250					VD4/Z8 24.12.25 p210	
	16				630			VD4/ZT8 24.06.16 p210	
	20				630			VD4/ZT8 24.06.20 p210	
	25				630			VD4/ZT8 24.06.25 p210	
	16				1250			VD4/ZT8 24.12.16 p210	
	20				1250			VD4/ZT8 24.12.20 p210	
	25				1250			VD4/ZT8 24.12.25 p210	
	16						630	VD4/ZS8 24.06.16 p210	
	20						630	VD4/ZS8 24.06.20 p210	
	25						630	VD4/ZS8 24.06.25 p210	
	16						1250	VD4/ZS8 24.12.16 p210	
	20						1250	VD4/ZS8 24.12.20 p210	
	25						1250	VD4/ZS8 24.12.25 p210	

W = Width of the switchgear.  
 P = Pole horizontal centre distance.  
 u/l = Distance between bottom and top terminal.  
 ø = Diameter of the isolating contact.

10 5 АДМІСТРАЦІЯ

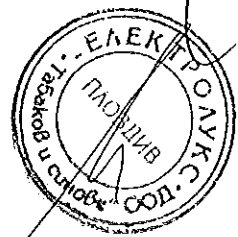

5.5.9. Standard fittings for withdrawable circuit-breakers for ZS8.4 switchgear

The basic versions of the withdrawable circuit-breakers are always three-pole and fitted with:

- EL type manual operating mechanism
- mechanical signalling device for closing spring charged/discharged
- mechanical signalling device for circuit-breaker open/closed
- closing pushbutton
- opening pushbutton
- operation counter
- set of ten auxiliary circuit-breaker open/closed contacts  
Note: with the set of ten auxiliary contacts supplied as standard and the maximum number of electrical applications possible, three make contacts (signalling circuit-breaker open) and four break contacts (signalling circuit-breaker closed) are available.
- lever for manually charging the closing springs incorporated in the operating mechanism for VD4/Z8 and VD4/ZT8, external with rotary movement for VD4/ZS8
- isolating contacts
- cord with connector (only plug) for auxiliary circuits, with striker pin which does not allow connection of the plug in the socket if the rated current of the circuit-breaker is different from the rated current of the panel
- racking-in/out lever (the quantity must be defined according to the number of pieces of apparatus ordered)

5.5.10. VD4/ZS8 (Preussen Elektra-EON version)

- Device for recharging the closing spring, with door closed, by means of removable rotary handle and outside the operating mechanism and the switchgear
- 64-pin Harting socket with mechanical interlock which prevents traverse of the circuit-breaker when the plug is not inserted in the socket
- Interlock with the door which prevents insertion of the spring charging lever when the circuit-breaker is closed
- Interlock with the door and the 64-pin Harting socket which prevents door closure when the plug is not inserted in the socket.

5.5.11. VD4/Z8 - VD4/ZT8

- Harting 64-pin socket with mechanical interlock which prevents traverse of the circuit-breaker when the plug is not inserted in the socket.

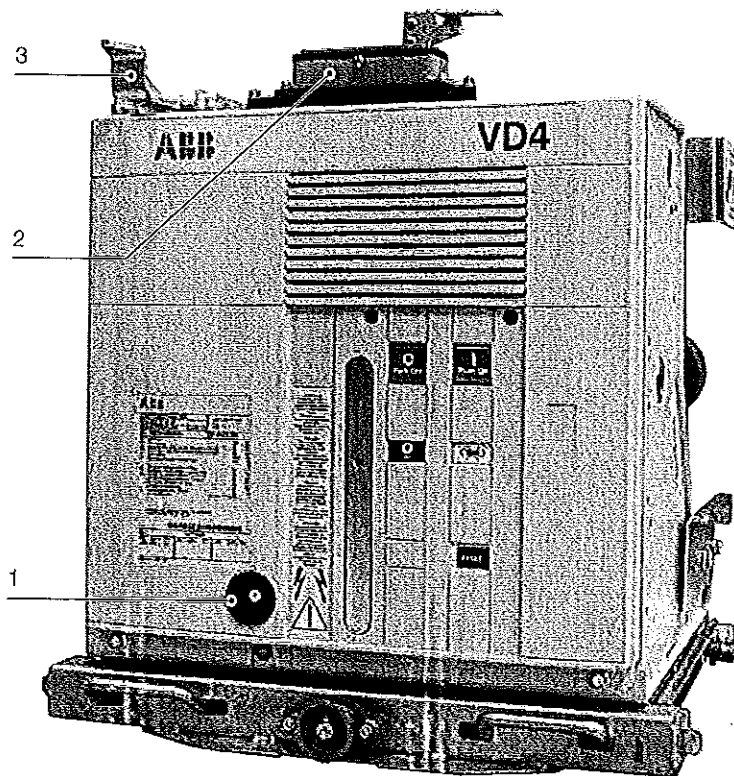

Caption

- 1) Device for spring charging with rotary handle
- 2) Harting 64-pin socket with mechanical interlock which prevents traverse when the socket is not inserted
- 3) Door-socket-spring charging device interlock (only VD4/ZS8 version)

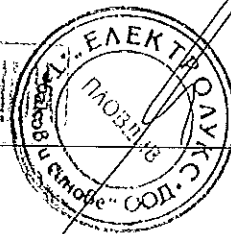



5.5.12. General characteristics of withdrawable circuit-breakers for UniSwitch switchgear and UniMix (24 kV) switchgear

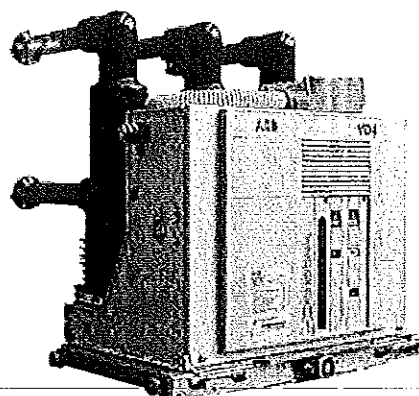

Circuit-breaker		VD4/US 24 <sup>(3)</sup>		VD4/US 24 <sup>(4)</sup>	
	UniSwitch (unit CBW type)	•	•	-	-
	UniMix (unit P1/E type)	-	-	•	•
Standards	IEC 62271-100	•	•	•	•
	VDE 0671; CEI EN 62271-100- File 7642	•	•	•	•
Rated voltage	Ur [kV]	24	24	24	24
Rated insulation voltage	Us [kV]	24	24	24	24
Withstand voltage at 50 Hz	Ud (1 min) [kV]	50	50	50	50
Impulse withstand voltage	Up [kV]	125	125	125	125
Rated frequency	fr [Hz]	50-60	50-60	50-60	50-60
Rated normal current (40 °C) <sup>(1)</sup>	Ir [A]	630	1250	630	1250
Rated breaking capacity (rated symmetrical short-circuit current)	Isc [kA]	16 (20) <sup>(5)</sup>	16 (25) <sup>(5)</sup>	16	16
		20 (25) <sup>(5)</sup>	20 (25) <sup>(5)</sup>	20	20
Rated short-time withstand current (3 s) <sup>(2)</sup>	Ikt [kA]	16 (20) <sup>(5)</sup>	16 (25) <sup>(5)</sup>	16	16
		20 (25) <sup>(5)</sup>	20 (25) <sup>(5)</sup>	20	20
Making capacity	Ipk [kA]	40 (50) <sup>(5)</sup>	40 (50) <sup>(5)</sup>	40	40
		50 (63) <sup>(5)</sup>	50 (63) <sup>(5)</sup>	50	50
Operation sequence	[O - 0.3 s - CO - 16 s - CO]	•	•	•	•
Opening time	[ms]	33 ... 60	33 ... 60	33 ... 60	33 ... 60
Arcing time	[ms]	10 ... 15	10 ... 15	10 ... 15	10 ... 15
Total breaking time	[ms]	43 ... 75	43 ... 75	43 ... 75	43 ... 75
Closing time	[ms]	60 ... 80	60 ... 80	60 ... 80	60 ... 80
Maximum overall dimensions	H [mm]	680	680	680	680
	W [mm]	653	653	653	653
	D [mm]	742	742	742	742
	Pole distance P [mm]	210	210	210	210
Weight	[kg]	125	125	125	125
Standardised table of dimensions	1VCD	000047	000047	000047	000047
Operating temperature	[°C]	- 5 ... + 40	- 5 ... + 40	- 5 ... + 40	- 5 ... + 40
Tropicalization	IEC: 60068-2-30, 60721-2-1	•	•	•	•
Electromagnetic compatibility	IEC 62271	•	•	•	•

(1) Rated current guaranteed with withdrawable circuit-breaker installed in switchgear with 40 °C ambient temperature  
 (2) The value and duration of the rated short-time withstand current depends on the switchgear. See the specific catalogues of the UniSwitch and UniMix switchgear  
 (3) The top shutter activation wheels of the UniSwitch switchgear (CBW unit) are mounted and adjusted by the manufacturer of the UniSwitch switchgear  
 (4) The top shutter activation wheels of the UniMix switchgear (P1/E unit) are available on request  
 (5) The values in brackets refer to the 12 kV rated voltage.

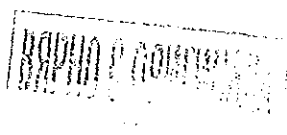

5.5.13. General characteristics of withdrawable circuit-breakers for UniSec switchgear

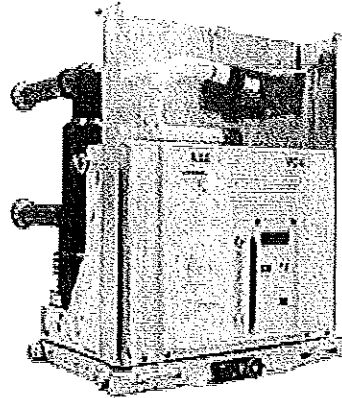

*[Handwritten signature]*

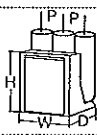
Circuit-breaker		VD4/SEC	
Standards	IEC 62271-100 • VDE 0671; CEI EN 62271-100- File 7642 •		
Rated voltage	Ur [kV]	24	
Rated insulation voltage	Us [kV]	24	
Withstand voltage at 50 Hz	Ud (1 min) [kV]	50	
Impulse withstand voltage	Up [kV]	125	
Rated frequency	fr [Hz]	50-60	
Rated normal current (40 °C) <sup>(1)</sup>	Ir [A]	630 - 1250	
Rated breaking capacity (rated symmetrical short-circuit current)	Isc [kA]	16 20 25	
	Rated short-time withstand current (3 s)	Ik [kA]	16 20 25
			40
Making capacity		Ip [kA]	50 63
Operation sequence	[O - 0.3 s - CO - 15 s - CO]	•	
Opening time	[ms]	33 ... 60	
Arcing time	[ms]	10 ... 15	
Total breaking time	[ms]	43 ... 75	
Closing time	[ms]	60 ... 80	
Maximum overall dimensions		H [mm]	743
		W [mm]	653
		D [mm]	742
		Pole distance P [mm]	210
Weight	[kg]	133	
Standardised table of dimensions	1VCD	000190	
Operating temperature	[°C]	- 5 ... + 40	
Tropicalization	IEC: 60068-2-30, 60721-2-1	•	
Electromagnetic compatibility	IEC 62271	•	

(1) Rated current guaranteed with withdrawable circuit-breaker installed in switchgear with 40 °C ambient temperature.

*[Handwritten signature]*

*[Handwritten text]*



5.5.14. Standard fittings for withdrawable circuit-breakers for UniSwitch, UniMix and UniSec switchgear

The basic versions of the withdrawable circuit-breakers are three-pole and provided with:

- EL type manual operating mechanism
- Mechanical signalling device for closing spring charged/discharged
- Mechanical signalling device for circuit-breaker open/closed
- Closing pushbutton
- Opening pushbutton
- Operation counter
- Set of ten circuit-breaker open/closed auxiliary contacts  
Note: with the set of ten auxiliary contacts supplied as standard and the maximum electrical accessories, three break contacts are available (signalling circuit-breaker open) and four make contacts (signalling circuit-breaker closed).
- Lever for manual charging of the closing spring incorporated in the operating mechanism
- Isolating contacts
- Racking-out/racking-in lever (the quantity must be established according to the number of pieces of apparatus ordered).

VD4 withdrawable circuit-breaker for switchgear UniSwitch (type unit CBW) and UniMix (type unit P1/E)

Ur	Isc	Rated uninterrupted current (40 °C) [A]		Circuit-breaker type	
		UniSwitch CBW	UniMix P1/E		
kV	kA	P=210	P=210		
		u/l=310	u/l=310		
		ø=35	ø=35		
		16	630		VD4/US 24.06.16 p210
		20	630 <sup>(1)</sup>		VD4/US 24.06.20 p210
		24	630		VD4/US 24.06.25 p210
24	kA	16	1250 <sup>(1)</sup>	VD4/US 24.12.16 p210	
		20	1250 <sup>(1)</sup>	VD4/US 24.12.20 p210	
		25	1250	VD4/US 24.12.25 p210	
		25	1250	VD4/US 24.12.25 p210	

(1) 25 kA Isc at the 12 kV rated voltage  
P = Pole horizontal centre distance.  
u/l = Distance between bottom and top terminal.  
ø = Diameter of the isolating contact.

VD4 withdrawable circuit-breaker for switchgear UniSec

Ur	Isc	Rated uninterrupted current (40 °C) [A]		Circuit-breaker type	
		P=210			
kV	kA	u/l=310			
		ø=35			
		16	630		VD4/SEC 24.06.16 p210
		20	630		VD4/SEC 24.06.20 p210
		24	630		VD4/SEC 24.06.25 p210
		24	1250		VD4/SEC 24.12.16 p210
24	kA	20	1250	VD4/SEC 24.12.20 p210	
		25	1250	VD4/SEC 24.12.25 p210	

P = Pole horizontal centre distance.  
u/l = Distance between bottom and top terminal.  
ø = Diameter of the isolating contact.

5.6. Characteristics of the electrical accessories

- Shunt opening release (-MO1)
- Additional shunt opening release (-MO2)
- Shunt closing release (-MC)
- Locking magnet on the actuator (-RL1)

Un	24 - 30 - 48 - 60 - 110 - 125 - 220 - 250 V-
Un	48 - 60 - 110 - 120 - 127 - 220 ... 240 V- 50 Hz
Un	110 - 120 - 127 - 220 - 240 V- 60 Hz
Operating limits	70 ... 110% Un
Inrush power (Ps)	DC 200 W; AC = 200 VA
Inrush time	approx. 100 ms
Continuous power (Pc)	DC = 5 W; AC = 5 VA
Opening time	35 ... 60 ms
Closing time	30 ... 80 ms
Insulation voltage	2000 V 50 Hz (for 1 min)

Undervoltage release (-MU)

Un	24 - 30 - 48 - 60 - 110 - 125 - 220 - 250 V-
Un	48 - 60 - 110 - 120 - 127 - 220 ... 240 V- 50 Hz
Un	110 - 120 ... 127 - 220 ... 240 V- 60 Hz
Operating limits	
- circuit-breaker opening	35-70% Un
- circuit-breaker closing	85-110% Un
Inrush power (Ps)	DC 200 W; AC = 200 VA
Inrush time	approx. 100 ms
Continuous power	DC = 5 W; AC = 5 VA
Opening time	60 ... 80 ms
Insulation voltage	2000 V 50 Hz (for 1 min)

Electronic time delay device for undervoltage release (mounted outside the circuit-breaker)

Un	24 ... 30 - 48 - 60 - 110 ... 127 - 220 ... 250 V-
Un	48 - 60 - 110 ... 127 - 220 ... 240 V- 50/60 Hz
Adjustable opening time (release + time delay device)	0.5-1-1.5-2-3 s

Motor for motorised truck (-MT) (only for withdrawable circuit-breakers for UniGear ZS1, UniSec and ZS8.4 switchgear)

Un	24-30-48-60-110-220 V DC
Operating limits	85 ... 110% Un
Rated power (Pn)	40 W

Motor operator (-MS)

Characteristics		
Un	24...30 - 48...60 - 110...130 - 220...250 V-	
Un	100...130 - 220...250 V ~ 50/60 Hz	
Operating limits	85 ... 110% Un	
Inrush power (Ps)	≤ 40 kA	50 kA
	DC=600 W; AC=600 VA	DC=900 W; AC=900 VA
Rated power (Pn)	DC=200 W; AC=200 VA	DC=350 W; AC=350 VA
Inrush time	0.2 s	0.2 s
Charging time	6-7 s	6-7 s
Insulation voltage	2000 V 50 Hz (for 1 min)	2000 V 50 Hz (for 1 min)

Auxiliary contacts of the circuit-breaker

Rated insulation voltage according to VDE 0110, Group G	660 V AC 800 V DC
Rated voltage	24 V... 660 V
Insulation-test test voltage	2.5 kV
Maximum rated current	10 A
Number of contacts	5
Stroke	6 mm ... 7 mm
Contact force	26 N
On resistance	3 mΩ
Storing temperature range	- 20° C ... + 120 °C
Operating temperature range	- 20° C ... + 70 °C
Contact over temperature	20 K
Operating cycles	30,000
Unlimited short circuit stability by using fuses of max. 10 A time-lag	

Uos <sub>en</sub>	Rated current	Breaking capacity	
220 V AC	0.7	2.5 A	25 A
380 V AC	0.7	1.5 A	15 A
500 V AC	0.7	1.5 A	15 A
660 V AC	0.7	1.2 A	12 A
	Time constant		
24 V DC	1 ms	10 A	12 A
	15 ms	10 A	12 A
	50 ms	8 A	10 A
	200 ms	4 A	7.7 A
60 V DC	1 ms	8 A	10 A
	15 ms	6 A	8 A
	50 ms	5 A	6 A
	200 ms	4 A	5.4 A
110 V DC	1 ms	6 A	8 A
	15 ms	4 A	5 A
	50 ms	2 A	4.6 A
	200 ms	1 A	2.2 A
220 V DC	1 ms	1.5 A	2 A
	15 ms	1 A	1.4 A
	50 ms	0.75 A	1.2 A
	200 ms	0.5 A	1 A

Note

With the set of 10 auxiliary contacts supplied as standard, the following are available:  
 - 3 NO contacts + 5 NC contacts for fixed circuit-breakers  
 - 3 NO contacts + 4 NC contacts for withdrawable circuit-breakers

With the set of 15 auxiliary contacts (+5 contacts on request compared to the 10 supplied as standard), the following are available:

- for fixed circuit-breaker, as desired, 6 NO contacts + 7 NC contacts or 5 NO contacts + 8 NC contacts or 3 NO contacts + 10 NC contacts
- for withdrawable circuit-breakers, depending on the applications required, a maximum of 6 NO contacts + 6 NC contacts and a minimum of 5 NO contacts + 5 NC contacts are available.

Locking magnet on the truck (-RL2) (\*)

Un	24 - 30 - 48 - 60 - 110 - 125 - 127 - 132 - 220 - 240 V-
Un	24 - 30 - 48 - 60 - 110 - 125 - 127 - 220 - 230 ... 240 V- 50/60 Hz
Operating limits	85 ... 110% Un
Inrush power (Ps)	DC = 250 W; AC = 250 VA
Continuous power (Pc)	DC = 5 W; AC = 5 VA
Inrush time	150 ms

(\*) Not available for versions with motorized truck.

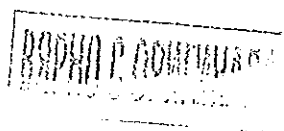

## 6. Instructions for operating the circuit-breaker

### 6.1. Safety indications

 The VD4 circuit-breakers guarantee a minimum IP2X degree of protection when installed in the following conditions:

- fixed circuit-breaker, installed behind a protective metal net
- withdrawable circuit-breaker, installed in switchgear.

Under these conditions the operator is totally guaranteed against accidental contact with moving parts.

Should mechanical operations be carried out on the circuit-breaker outside of the switchgear, take great care of the moving parts.

If the operations are prevented, do not force the mechanical interlocks and check that the operating sequence is correct.

Racking the circuit-breaker in and out of the switchgear must be done gradually to avoid shocks which may deform the mechanical interlocks. Due to safety reasons, the circuit-breaker has to be treated as "switched on" if the switching position cannot be clearly determined.

In this case all high voltage connections to the circuit-breaker have to be de-energized and zero potential on the primary side of the circuit-breaker has to be confirmed prior to commissioning, operation, maintenance or repair work.

### 6.2. Switching and signalling parts

VD4 circuit-breakers for UniGear switchgear and PowerCube modules (fig. 6a)

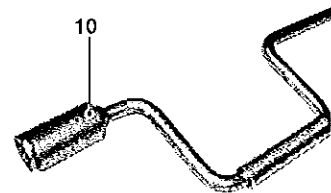
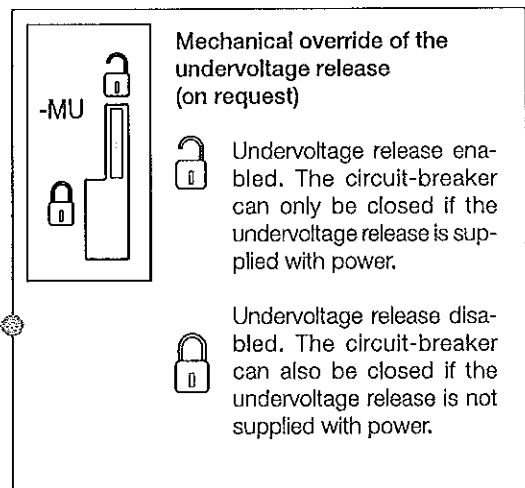
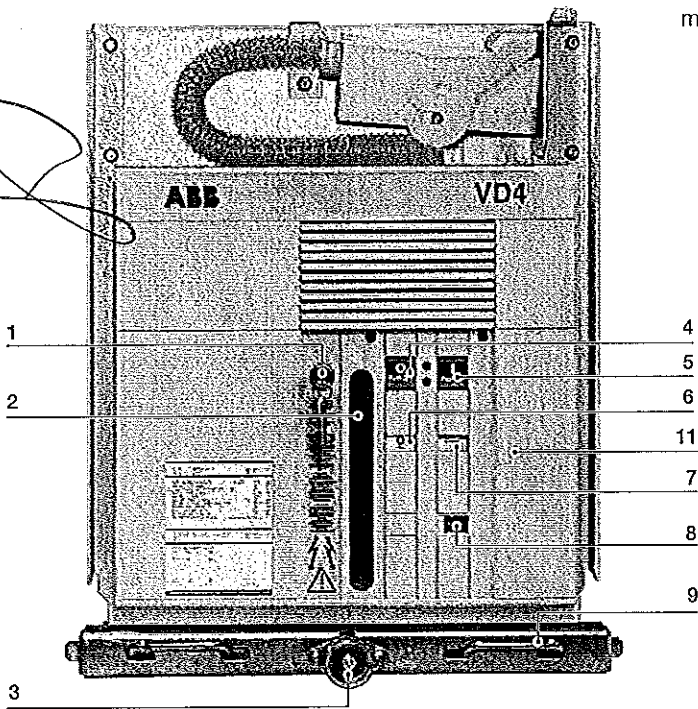

#### Caption

- 1 Key lock (if provided) (\*)
- 2 Lever for manually charging the closing spring (except version VD4/ZS8 - see figure 6b)
- 3 Coupling lever for racking-out operation (withdrawable circuit-breakers only)
- 4 Opening pushbutton
- 5 Closing pushbutton
- 6 Signalling device for circuit-breaker open/closed
- 7 Signalling device for closing springs charged/discharged
- 8 Operation counter.
- 9 Handles for operating the truck locks (only for withdrawable circuit-breakers)
- 10 Operating lever for circuit-breaker racking-in/out (there is a special version for VD4/ZS8)
- 11 Mechanical undervoltage release override (on request).

(\*) Warning! To activate the key lock: open the circuit-breaker, keep the opening pushbutton depressed, then turn the key and remove it from the housing.

Fig. 6a

## 6.3. Circuit-breaker closing and opening operations

Circuit-breaker operation can be either manual or electrical (fig. 6 - fig. 7).

### a1) Manual closing spring charging for VD4 circuit-breakers for UniGear switchgear and PowerCube modules (fig. 7a)

Repeatedly activate the charging lever (2) (maximum rotation angle of the lever: about 90°) until the yellow indicator (7) appears.

The maximum forces which can normally be applied to the lever are  $\leq 150$  N for the EL1 operating mechanism,  $\leq 200$  N for the EL2 operating mechanism and  $\leq 250$  N for EL3 operating mechanism.

EL1 Twin and EL2 Twin type operating mechanisms are provided for circuit-breakers with 50 kA breaking capacity. For manual charging, the additional lever (1) should be inserted fully, as indicated in fig. 7c. In this way, the maximum force to be applied is  $\leq 200$  N. For the type of operating mechanism, please refer to the rating plate in fig. 1.

### a2) Closing spring loading in the manual mode for withdrawable VD4 circuit-breakers for UniGear switchgear equipped with a hand-operated rotary loading device for the closing spring (refer to fig. 6b for indicative details)

Rotate the charging lever (2) (rotate about 12 times) until the yellow indicator (7) appears. The maximum force which can normally be applied to the lever is  $\leq 150$  N for the EL1 operating mechanism and  $\leq 230$  N for the EL3 operating mechanism.

The operation can be carried out with the door either open or closed and the circuit-breaker either withdrawn or connected.

**WARNING (fig. 6b):** Fit the hand-operated loading lever of the closing spring (2b) into its housing (2a). Turn the lever clockwise (about 12 times) until the yellow indicator (7) appears to show that loading is complete. Once this happens, the lever will continue for half a turn without loading (without exercising any force), after which it will lock owing to a sudden load increase. Do not exercise force or try to continue loading as this will damage the device.

### VD4 circuit-breakers for ZS8.4 switchgear (fig. 6b)

#### a3) Manual closing spring charging for VD4 circuit-breakers (fig. 7b)

Rotate the charging lever (2) until the yellow indicator (7) appears. The maximum force which can normally be applied to the lever is  $\leq 150$  N for the EL1 operating mechanism and  $\leq 230$  N for the EL3 operating mechanism.

The operation can be carried out with the door either open or closed and the circuit-breaker either withdrawn or connected.

**WARNING (fig. 6b):** Fit the hand-operated loading lever of the closing spring (2b) into its housing (2a). Turn the lever clockwise (about 12 times) until the yellow indicator (7) appears to show that loading is complete. Once this happens, the lever will continue for half a turn without loading (without exercising any force), after which it will lock owing to a sudden load increase. Do not exercise force or try to continue loading as this will damage the device.

#### b) Electrical spring charging operation

On request, the circuit-breaker can be fitted with the following accessories for electrical operation:

- geared motor for automatic closing spring charging
- shunt closing release
- shunt opening release.

The geared motor automatically recharges the spring after each closing operation until the yellow indicator (7) appears. If the power is cut off during charging, the geared motor stops and automatically starts recharging the springs again when the power returns.

In any case, it is always possible to complete the charging operation manually.

#### c) Circuit-breaker closing

The operation can only be carried out with the closing spring completely charged.

For manual closing, press the pushbutton (5 - fig. 6b).

When there is a shunt closing release, the operation can also be carried out remotely by means of a special control circuit. Closing having taken place is indicated by the signalling device (6 - fig. 6b).

#### d) Circuit-breaker opening

For manual opening, press the pushbutton (4 - fig. 6b).

When there is a shunt opening release, the operation can also be carried out remotely by means of a special control circuit.

Opening having taken place is indicated by the signalling device (6 - fig. 6b).

РОПІС П РОЗКРИТТЯ



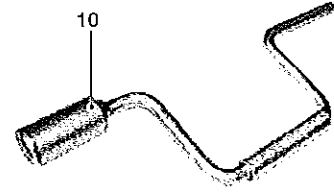
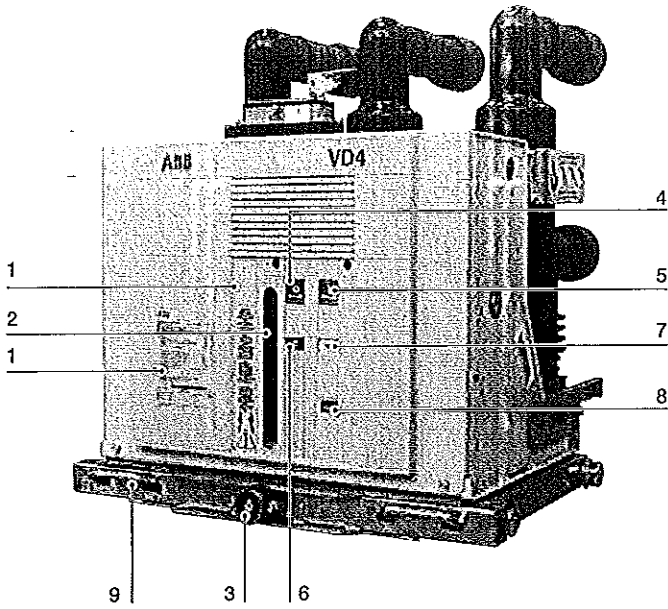

*[Handwritten signature]*

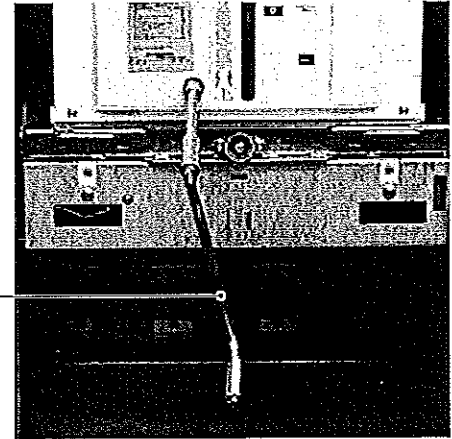

2b

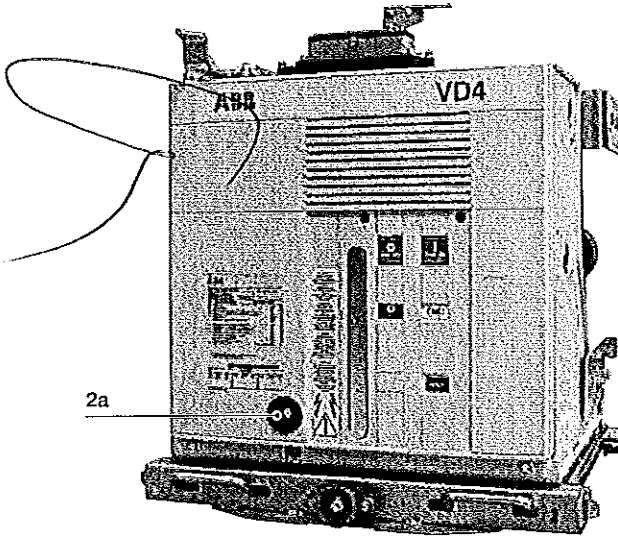

Caption

- 1 Key lock (if provided)
- 2 Lever for manually charging the closing spring
  - 2a Coupling for manual closing spring charging (when lever 2 is not provided)
  - 2b Lever for manual closing spring charging for rotary charging device
- 3 Coupling for racking-out operation lever (only for withdrawable circuit-breakers)
- 4 Opening pushbutton
- 5 Closing pushbutton
- 6 Signalling device for circuit-breaker open/closed
- 7 Signalling device for closing spring charged/discharged
- 8 Operation counter.
- 9 Handles for operating the truck locks (only for withdrawable circuit-breakers)
- 10 Operating lever for circuit-breaker racking-in/out.

Fig. 6b

РОПД П. ГОРЬВАНОВ



*[Handwritten signature]*

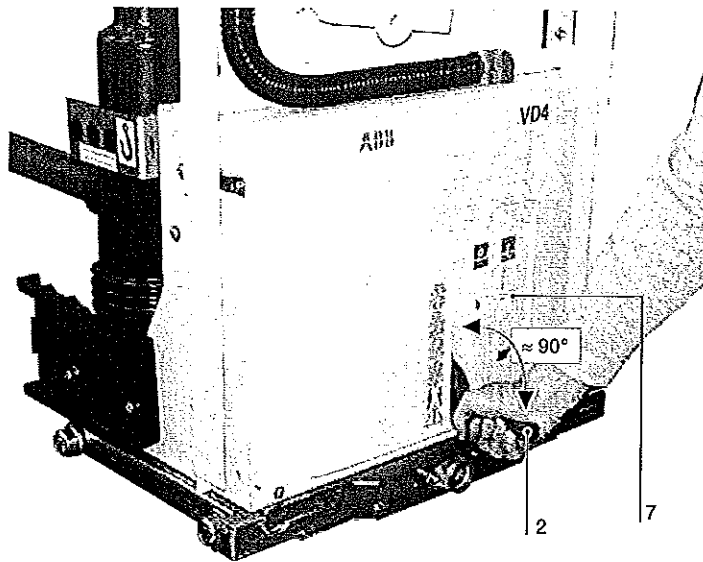

*[Handwritten signature]*

Fig. 7a

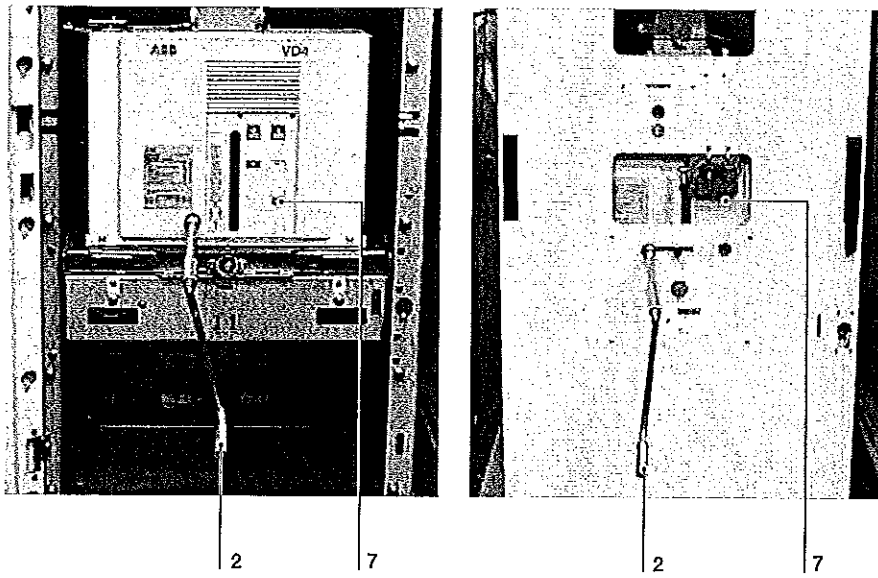

*[Handwritten signature]*

Fig. 7b

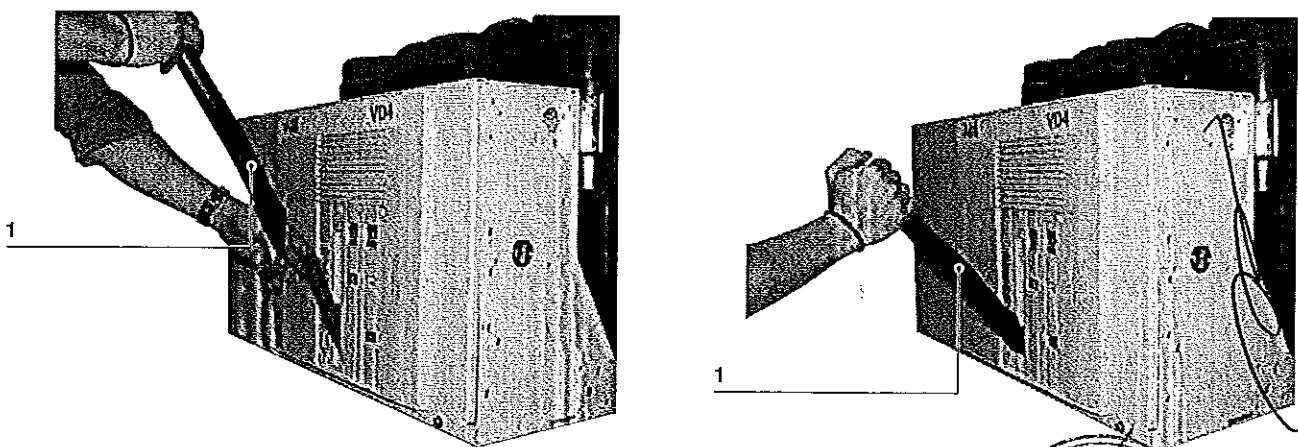

Fig. 7c

*[Faint rectangular stamp]*

ЭЛЕКТРОАКС.  
ИЗВЕЩАНИЕ  
У СЛУЖБЕ ООД.  
*[Handwritten signature]*



# 7. Installation

## 7.1. General

**⚠** Correct installation is of primary importance. The manufacturer's instructions must be carefully studied and followed. It is good practice to use gloves for handling the pieces during installation.

## 7.2. Installation and operating conditions

The following Standards must be taken into particular consideration during installation and service:

- IEC 62271-1/DIN VDE 0101
- VDE 0105: Electrical installation service
- DIN VDE 0141: Earthing systems for installations with rated voltage above 1 kV
- All the accident prevention regulations in force in the relative countries.

### 7.2.1. Normal conditions

Follow the recommendations in the IEC 62271-1 and 62271-100 Standards. In more detail:

#### Ambient temperature

Maximum	+ 40 °C
Average maximum over 24 hours	+ 35 °C
Minimum (according to class - 5), apparatus for indoor installation	- 5°

#### Humidity

The average value of the relative humidity, measured for a period longer than 24 hours, must not exceed the 95%.

The average value of the pressure of the water vapour, measured for a period longer than 24 hours, must not exceed 2.2 kPa.

The average value of the relative humidity, measured for a period longer than 1 month, must not exceed the 90%.

The average value of the pressure of the water vapour, measured for a period longer than 1 month, must not exceed 1.8 kPa.

#### Altitude

≤ 1000 m above sea level.

### 7.2.2. Special conditions

#### Installations over 1000 m a.s.l.

Possible within the limits permitted by reduction of the dielectric resistance of the air.

#### Increase in the ambient temperature

Reduction in the rated current.

Encourage heat dissipation with appropriate additional ventilation.

#### Climate

To avoid the risk of corrosion or other damage in areas:

- with a high level of humidity, and/or
- with rapid and big temperature variations, take appropriate steps (for example, by using suitable electric heaters) to prevent condensation phenomena.

For special installation requirements or other operating conditions, please contact ABB.

**⚠** The areas involved by the passage of power conductors or auxiliary circuit conductors must be protected against access of any animals which might cause damage or disservices.

### 7.2.3. Trip curves

The following graphs show the number of closing-opening cycles (No.) allowed, of the vacuum interrupters, according to the breaking capacity (Ia).

Caption (Figs. 8...)

No. Number of closing-opening cycles allowed for the vacuum interrupters.

Ia: Breaking capacity of the vacuum interrupters.

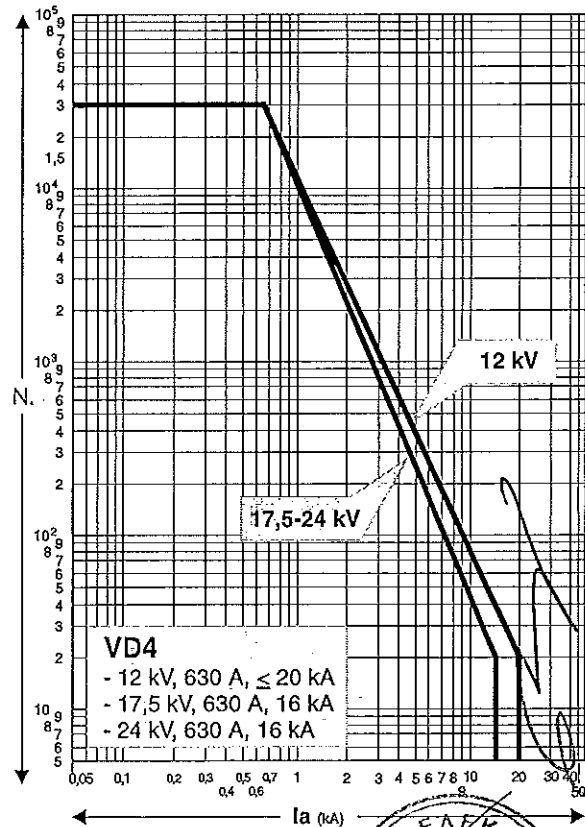

Fig. 8a



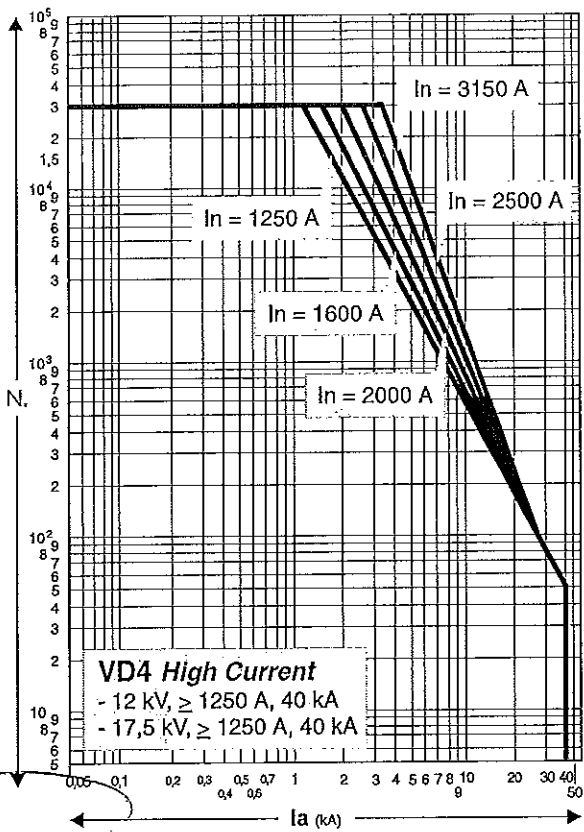

Fig. 8f

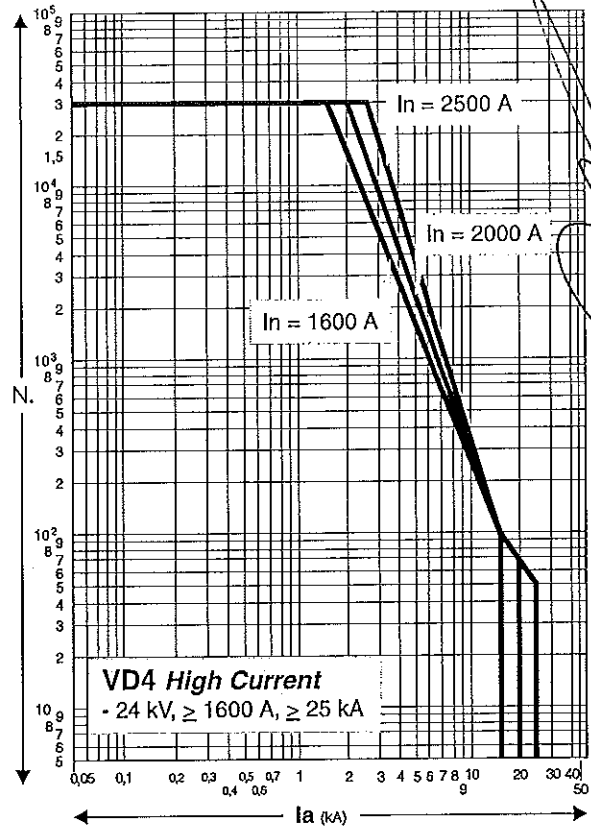

Fig. 8g

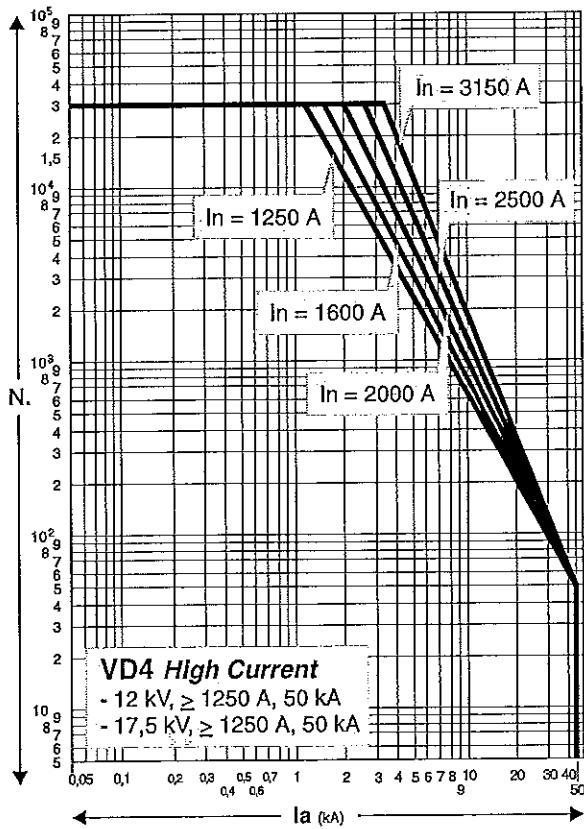
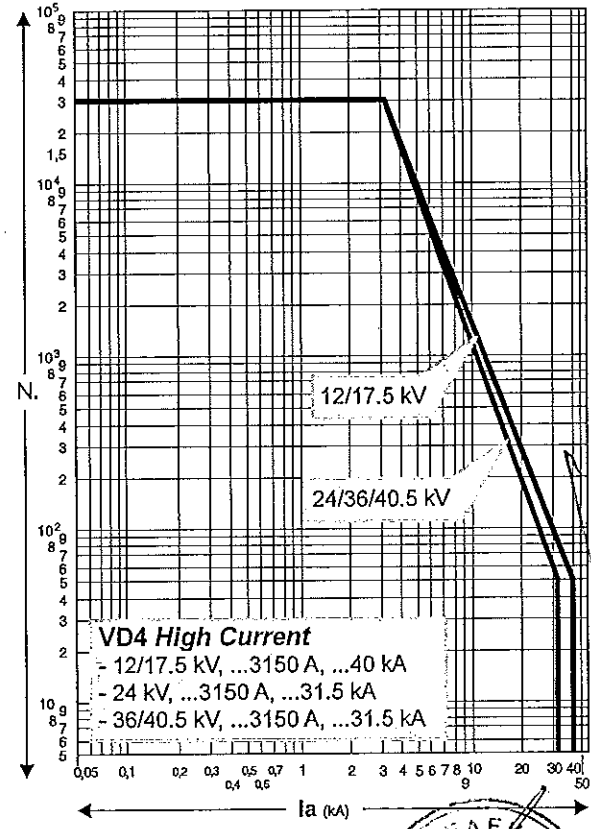
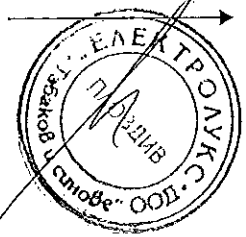

Fig. 8h



ВОПРОСЫ ПО ТЕХНИЧЕСКИМ ВОПРОСАМ

Fig. 8i



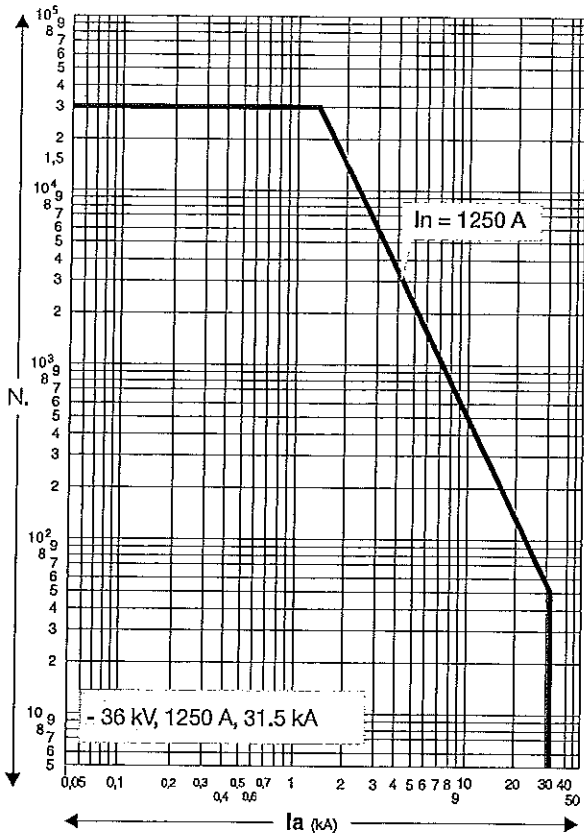

Fig. 8l

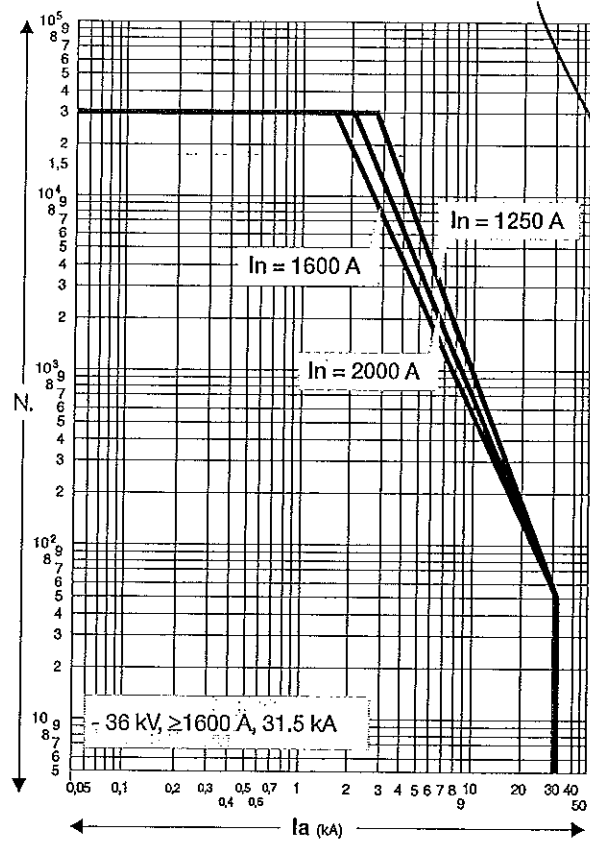

Fig. 8m

### 7.3. Preliminary operations

- Clean the insulating parts with clean dry cloths.
- Check that the top and bottom terminals are clean and free of any deformation caused by shocks received during transport or storage.

### 7.4. Installation of fixed circuit-breakers

The circuit-breaker can be mounted directly on supporting frames to be provided by the customer, or on a special supporting truck (available on request).

The circuit-breaker, with supporting truck, must be suitably fixed to the floor of its own compartment by the customer. The floor surface in correspondence with the truck wheels must be carefully levelled.

A minimum degree of protection (IP2X) must be guaranteed from the front towards live parts.

#### 7.4.1. Mounting the circuit-breaker on a truck made by other manufacturers

The VD4 circuit-breakers which are not installed on ABB trucks, but on trucks made by the customer, must be fitted with one or two additional auxiliary contacts (activated by the

mechanical lock and by the circuit-breaker release device) to carry out the function of interrupting the shunt closing release circuit (-MC) during traverse from isolated and vice versa. In ABB trucks, this function is carried out by the -BT1 and -BT2 auxiliary contacts which cut off the release power supply during and before activation of the mechanical lock of the screw truck racking-in device. This means that the shunt closing release power supply can only be applied at the end of activation of the mechanical lock. In this way it is certain that no electrical impulse can activate the shunt closing release with the circuit-breaker in an intermediate position.

### 7.5. Installation of withdrawable circuit-breaker

The withdrawable circuit-breakers are preset for use in UniGear ZS1, UniGear ZS2, UniSec switchgear and PowerCube modules.

For racking-in/racking-out of the switchgear, fully insert the lever (1) (fig. 9) in the appropriate seat (2) and work it clockwise for racking-in, and anti-clockwise for racking-out, until the limit switch positions are reached.

Circuit-breaker racking-in/-out must be carried out gradually to avoid shocks which may deform the mechanical interlocks and the limit switches.

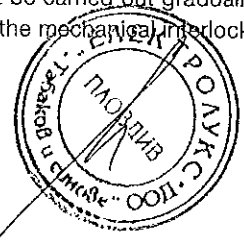
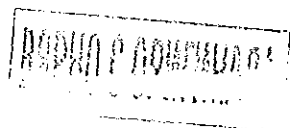

The torque normally required to carry out racking-in and racking-out is  $<25$  Nm.

This value must not be exceeded. If operations are prevented or difficult, do not force them and check that the operating sequence is correct.

**Note**

To complete the racking-in/out operation, about 20 rotations of the lever are required for circuit-breakers up to 17.5 kV, and about 30 rotations for 24 kV circuit-breakers.

When the circuit-breaker has reached the isolated for test/ isolated position, it can be considered racked into the switchgear and, at the same time, earthed by means of the truck wheels.

Withdrawable circuit-breakers of the same version, and therefore with the same dimensions, are interchangeable. However, when, for example, different electrical accessory fittings are provided, a different code for the plug of the auxiliary circuits does not allow incorrect combinations between panels and circuit-breakers.

For the circuit-breaker installation operations, also refer to the technical documentation of the above-mentioned switchgear.



- The racking-in/-out operations must always be carried out with the circuit-breaker open.
- When putting into service for the first time, it is advisable to charge the circuit-breaker operating mechanisms manually so as not to overload the auxiliary power supply circuit.

**7.5.1. Circuit-breakers with withdrawable motorized truck**

Carry out the racking-in/racking-out test of the motorized truck in the same way as for a manual truck, following the instructions below:

- Rack the circuit-breaker into the switchgear in the open and isolated position, with the power supply to the motor circuit cut off and with the enclosure door closed.

- Insert the manual racking-in lever (1) in the special coupling (2) Fig. 9, and take the motorized truck to about half its run between the isolated for test and the connected position. The torque needed to carry out truck handling is  $\leq 25$  Nm. In the case of accidental inversion of the truck motor power supply polarity, this operation allows a possible error in direction to be dealt with without any damage. Verification checks:

- motor rotation clockwise during circuit-breaker racking-in.
  - motor rotation anticlockwise during circuit-breaker racking-out.
- Remove the manual lever (1) from the coupling (2) Fig. 9
  - Supply the truck motor circuit.
  - Activate the control for the electrical racking-in operation. When racking-in has taken place, check correct changeover of the relative auxiliary contact.
  - On completion, activate the control for the electrical racking-out operation. When racking-out has taken place, check correct changeover of the relative auxiliary contact.
  - In the case of a motor fault during a racking-in or racking-out operation, in an emergency the truck can be taken to the end of its run manually, after first cutting off the power supply to the motor power supply circuit and then, using the manual lever, work in the same way as with the manual truck.

**Note**

By means of the chain transmission, truck handling carried out using the manual lever makes the truck motor armature rotate which, behaving like a generator, can cause inverse voltage at the connection terminals. This may damage the permanent magnet of the motor, therefore all the truck racking-in and racking-out operations carried out using the manual lever must be done without power supply in the motor circuit.

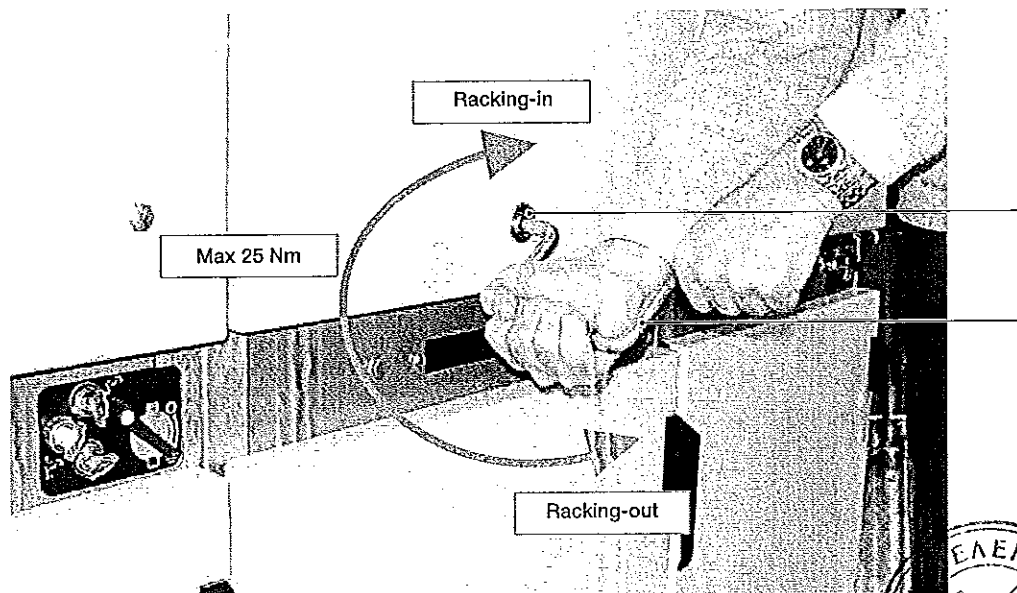
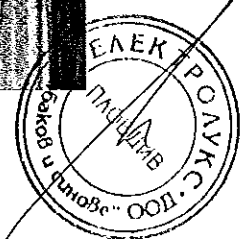

Fig. 9

ВОПРОСЫ И ОТВЕТЫ



## 7.6. Power circuit connections of fixed circuit-breakers

### 7.6.1. General recommendations

- Select the cross-section of the conductors according to the service current and the short-circuit current of the installation.
- Prepare special pole insulators, near the terminals of the fixed circuit-breaker or of the enclosure, sized according to the electrodynamic forces deriving from the short-circuit current of the installation.

### 7.6.2. Assembly of the connections

- Check that the contact surfaces of the connections are flat, and are free of any burrs, traces of oxidation or deformation caused by drilling or impacts received.
- According to the conductor material and the surface treatment used, carry out the operations indicated in table T1 on the contact surface of the conductor.

#### Assembly procedure

- Put the connections in contact with the circuit-breaker terminals, taking care to avoid mechanical stresses (traction / compression) on, for example, the conducting busbars on the terminals.
- Interpose a spring washer and a flat washer between the head of the bolt and the connection.
- It is advisable to use bolts according to DIN class 8.8 Standards, also referring to what is indicated in table T2.
- In the case of cable connections, strictly follow the manufacturer's instructions to make the terminals.

#### T1

##### Bare copper

- Clean with a fine file or emery cloth.
- Tighten fully and cover the contact surfaces with 5RX Moly type grease.

##### Copper or silver-plated aluminium

- Clean with a rough dry cloth.
- Only in the case of obstinate traces of oxidation, clean with a very fine grain emery cloth taking care not to remove the surface layer.
- If necessary, restore the surface treatment.

##### Bare aluminium

- Clean with a metal brush or emery cloth.
- Cover the contact surfaces again immediately with neutral grease.
- Insert the copper-aluminium bimetal with surfaces shined (copper side in contact with the terminal; aluminium side in contact with the connection) between the aluminium connection and the copper terminal.

#### T2

Bolt	Recommended tightening torque <sup>(1)</sup>	
	Without lubricant	With lubricant <sup>(2)</sup>
M6	10,5 Nm	4,5 Nm
M8	26 Nm	10 Nm
M10	50 Nm	20 Nm
M12	86 Nm	40 Nm
M16	200 Nm	80 Nm

(1) The nominal tightening torque is based on a friction coefficient of the thread of 0.14 (distributed value the thread is subjected to which, in some cases, is not negligible). The nominal tightening torque with lubricant is according to the DIN 43673 Standards.

(2) Oil or grease. The thread and surfaces in contact with the lubricated heads.

Take into account the deviations from the general Standards table (for example, for systems in contact or terminals) as foreseen in the specific technical documentation. The thread and surfaces in contact with the heads of bolts must be slightly oiled or greased, so as to obtain a correct nominal tightening torque.

## 7.7. Earthing

For the fixed version circuit-breaker, carry out earthing by means of the special screw marked with the relative symbol. Clean and degrease the area around the screw to a diameter of about 30 mm and, on completion of assembly, cover the joint again with Vaseline grease. Use a conductor (busbar or braid) with a cross-section conforming to the Standards in force.

## 7.8. Connection of the auxiliary circuits

Note: the minimum cross-section of the wires used for the auxiliary circuits must not be less than the one used for the internal cabling. Furthermore, they must be insulated for 3 kV of test.

### 7.8.1. Fixed circuit-breaker

Connection of the circuit-breaker auxiliary circuits must be made by means of the terminal box (1) (fig. 10) mounted inside the circuit-breaker and the cables must pass through the connector (2).

Outside the connector, the cables must pass through a suitable metal protective cover (pipe, wiring duct, etc.), which must be earthed.

To prevent the cabling wires outside the circuit-breaker (carried out by the customer) from accidentally coming into contact with moving parts and therefore undergoing damage to the insulation, it is recommended to fix the wires as shown in fig. 10a.



**Before removing the operating mechanism cover to access the terminal box, check that the circuit-breaker is open and the closing spring discharged.**

### 7.8.2. Withdrawable circuit-breakers

The auxiliary circuits of withdrawable circuit-breakers are fully cabled in the factory as far as the connector (fig. 11). For the external connections, refer to the electric wiring diagram of the switchgear.

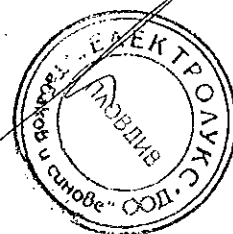
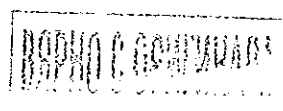

VD4 circuit-breaker for UniGear switchgear and PowerCube module.

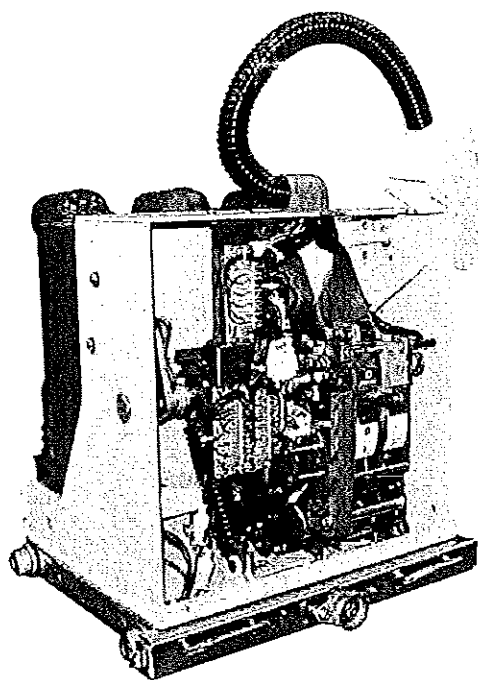
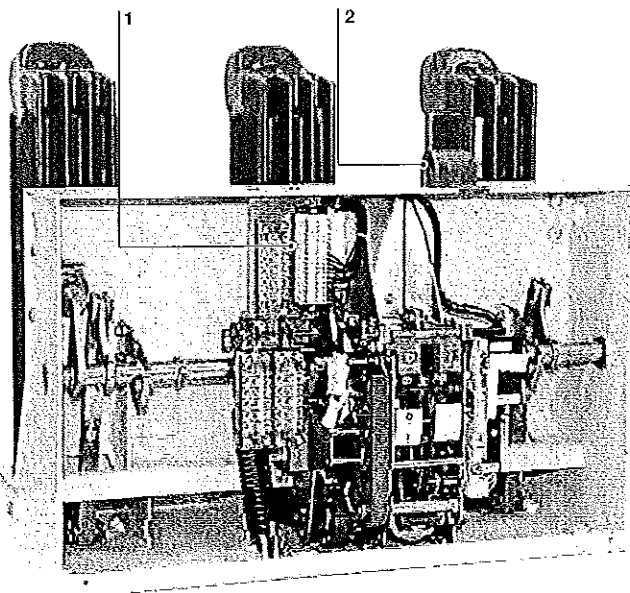

Fig. 10

VD4 circuit-breaker for ZS8.4 switchgear (VD4/ZS8 version with rotary charging).

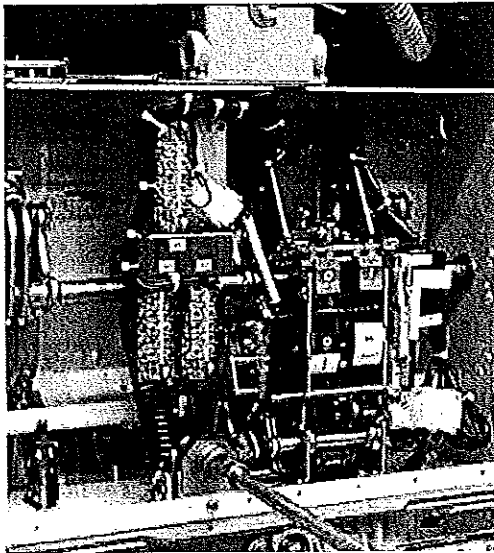
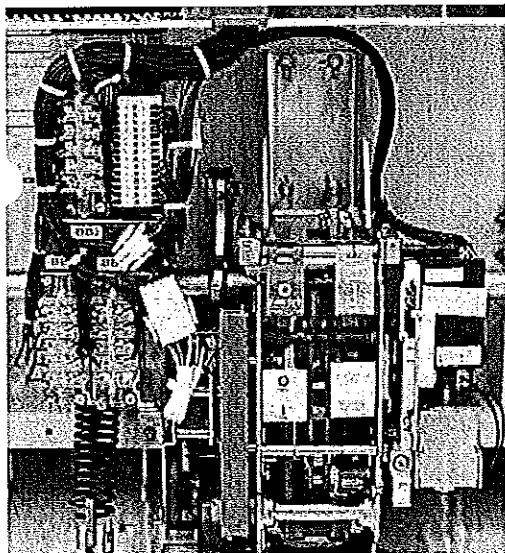

Fig. 10a

Fig. 11

Робота в розробку



## 8. Putting into service

### 8.1. General procedures

 All the operations regarding putting into service must be carried out by ABB personnel or by suitably qualified customer personnel with in-depth knowledge of the apparatus and of the installation. Should the operations be prevented, do not force the mechanical interlocks and check that the operating sequence is correct. The operating forces which can be applied for racking-in withdrawable circuit-breakers are indicated in paragraph 7.5.

Before putting the circuit-breaker into service, carry out the following operations:

- check tightness of the power connections to the circuit-breaker terminals;
- establish the setting of the primary electronic overcurrent release (if provided);
- check that the value of the power supply voltage of the auxiliary circuits is between 85% and 110% of the rated voltage of the electrical accessories;
- check that no foreign bodies, such as bits of packing, have got into the moving parts;
- check that there is a sufficient exchange of air in the installation place to avoid overtemperatures;
- also carry out the checks indicated in table T3.

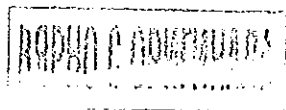



ITEM INSPECTED	PROCEDURE	POSITIVE CHECK
1 Insulation resistance.	Medium voltage circuit With a 2500 V megger, measure the insulation resistance between the phases and the exposed conductive part of the circuit.	The insulation resistance should be at least 50 Mohm and in any case constant over time.
	Auxiliary circuits With a 500 V megger (if the apparatus installed allows this), measure the insulation resistance between the auxiliary circuits and the exposed conductive part.	The insulation resistance should be a few Mohm and in any case constant over time.
2 Auxiliary circuits.	Check that the connections to the control circuit are correct: proceed at the relative power supply.	Operations and signals normal.
3 Manual operating mechanism.	Carry out a few closing and opening operations (see cap. 6). N.B. Supply the undervoltage release and the locking magnet on the operating mechanism at the relative rated voltage (if provided).	The operations and relative signals take place normally.
4 Motor operator (if provided).	Supply the spring charging geared motor at the relative rated voltage.	The spring is charged normally. The signals are normal. With the spring charged, the geared motor stops.
	Carry out a few closing and opening operations. N.B. Supply the undervoltage release and the locking magnet on the operating mechanism at the relative rated voltage (if provided).	The geared motor recharges the spring after each closing operation.
5 Undervoltage release (if provided).	Supply the undervoltage release at the relative rated voltage and carry out the circuit-breaker closing operation.	The circuit-breaker closes normally. The signals are normal.
	Cut off power to the release.	The circuit-breaker opens. The signalling changes over.
6 Shunt opening release and additional shunt opening release (if provided).	Close the circuit-breaker and supply the shunt opening release at the relative rated voltage.	The circuit-breaker opens normally. The signals are normal.
7 Shunt closing release (if provided).	Open the circuit-breaker and supply the shunt closing release at the relative rated voltage.	The circuit-breaker opens normally. The signals are normal.
8 Key lock (if provided).	Open the circuit-breaker, keep the opening pushbutton depressed, then turn the key and remove it from the housing. Attempt the circuit-breaker closing operation.	Neither manual nor electrical closing takes place.
	Put the key back in and turn it 90°. Carry out the closing operation.	Both electrical and manual closing take place normally; in this position the key cannot be removed.
9 Locking electromagnet (-RL1) (if provided).	With the circuit-breaker open, spring charged and locking electromagnet not supplied, attempt circuit-breaker closing both manually and electrically.	Closing is not possible.
10 Auxiliary contacts in the operating mechanism.	Insert the auxiliary contacts in suitable signalling circuits. Carry out a few closing and opening operations.	Signals take place normally.
11 Locking electromagnet on the truck circuit-breaker (-RL2) (if provided).	With the circuit-breaker open, in the Isolated for test position and the locking electromagnet not supplied, attempt racking-in of the circuit-breaker.	Racking-in is not possible.
	Supply the locking electromagnet and carry out the racking-in operation.	Racking-in takes place correctly.
12 Auxiliary transmitted contacts for signalling circuit-breaker racked-in, Isolated (UniGear switchgear or PowerCube modules).	Insert the auxiliary contacts in suitable signalling circuits. With the circuit-breaker racked into the enclosure, carry out a few traverse operations from the Isolated for test position to the connected position. Take the circuit-breaker to the racked-out position.	The signals due to the relative operations take place normally.

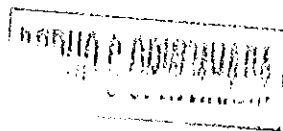

## 9. Maintenance

The maintenance operations are aimed at keeping the apparatus in good working condition for as long as possible. In accordance with what is specified in the IEC 61208 / DIN 31 051 Standards, the following operations must be carried out.

Inspection:	Finding out the actual conditions
Overhauling:	Measures to be taken to maintain the specific conditions
Repairs:	Measures to be taken to restore the specific conditions.

### 9.1. General

The vacuum circuit-breakers are characterised by simple, sturdy construction and a long life.

The operating mechanism requires maintenance and functional inspections to reach the expected operating-life (see par. 9.3.2.).

The vacuum interrupters are maintenance-free for their whole operating life.

Vacuum interruption does not produce any harmful effects even when there are frequent interruptions at the rated and short-circuit current.

The interventions during service and their aim are determined by the ambient conditions, by the sequence of operations and by the short-circuit interruptions.

#### Note

Respect the following Standards for maintenance work:

- the relative specifications given in the chapter on "Standards and Specifications";
- work safety regulations in the chapter on "Putting into service and operations";
- standards and specifications of the country where the apparatus is installed.

The maintenance operations must only be carried out by trained personnel and who follow all the safety regulations. Furthermore, it is advisable to call on ABB personnel, at least in cases for checking the performances in service and for repairs.

Cut the power supply off and put the apparatus under safe conditions during the maintenance operations.



**Before carrying out any operations, check that the circuit-breaker is open, with the spring discharged and that it is not supplied (medium voltage circuit and auxiliary circuits).**

#### 9.1.1. Operating life expectancy

The operating life expectancy for the VD4 circuit-breakers is as follows:

- vacuum interrupters: up to 30,000 operations, according to their type (see par. 7.2.3. Trip curves);

- switching device, actuator and transmission system: up to 30,000 operations, under normal operating conditions, according to the type of circuit-breaker and with regular maintenance (see par. 9.3.2.);
- with operations correctly executed it is possible to carry out up to 1000 racking-out/in operations (as prescribed in the IEC 60271-200 Standards);
- the data regarding the operating life are basically applicable to all the components which cannot be directly affected by operator activity. The manually operated components (moving parts of isolatable parts, etc.) can vary their behaviour.

### 9.2. Inspections and functionality tests

#### 9.2.1. Interruption devices in general

- Check the conditions of the interruption devices with regular inspections.
- Inspection at fixed intervals can be avoided when the apparatus is permanently under the control of qualified personnel.
- The checks must, first of all, include visual inspection to check for any contamination, traces of corrosion or electrical discharge phenomena.
- Carry out more frequent inspections when there are unusual operating conditions (including severe climatic conditions) and in the case of environmental pollution (e.g. high level of contamination or an atmosphere with aggressive agents).
- Visual inspection of the isolating contacts.

It is recommended to turn the contact system alternately in order to keep the internal surface of the contact areas clean. The contact areas must be cleaned when there are signs of overheating (discoloured surface) (also see Repairs).

- In the case of abnormal conditions, take suitable overhauling measures (see Overhauling par.).

#### 9.2.2. Stored energy operating mechanism

Carry out the functional test of the operating mechanism after 5,000 operations or during ordinary maintenance operations as specified in par. 9.2.1.

Before doing the test, open the circuit-breaker and carry out the following operations:

- in the case of withdrawable circuit-breakers, take the circuit-breaker to the isolated for test position
- in the case of fixed circuit-breakers: cut off the power supply to the medium voltage circuit.

#### Note

Insulate the work area and make it safe, following the safety regulations specified in the IEC/DIN VDE Standards.

ВЯРНО С ОПРИГНАЛА

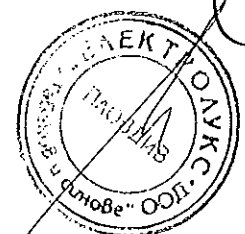

### Functional test

- With the circuit-breaker not connected to the load, carry out a few opening and closing operations.
- If foreseen, cut the power supply to the spring charging motor off. Discharge the spring by closing and opening the circuit-breaker by means of the closing and opening pushbuttons.
- Visually inspect the lubrication conditions of the tulip isolating contacts, of the sliding surfaces, etc.

- Check correct electrical and mechanical operation of the various devices, with particular attention to the interlocks.
- The screws and nuts are tightened in the factory and correct tightening is marked with a collared sign. No further tightening operations are foreseen during the operating life of the circuit-breaker. However, following any maintenance interventions, should it be necessary to re-tighten the screws or nuts, it is recommended to always replace the screws and nuts and to keep to the values indicated in fig. 12.

### Checking tightness of the screws

25 Nm

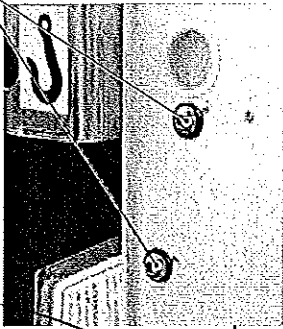

15 Nm

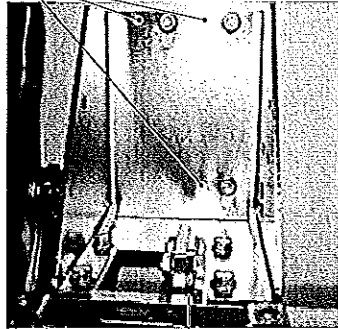

15 Nm

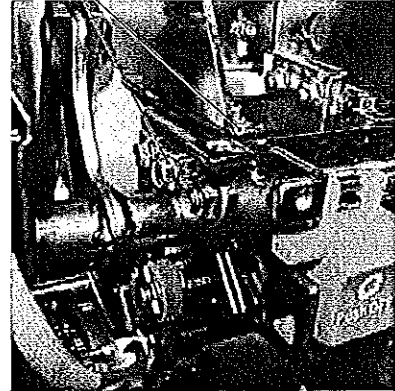

15 Nm

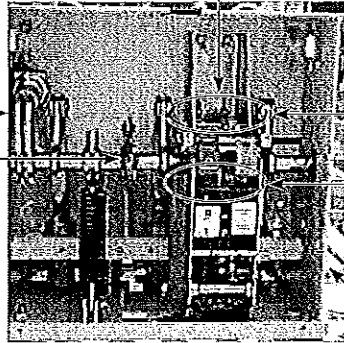
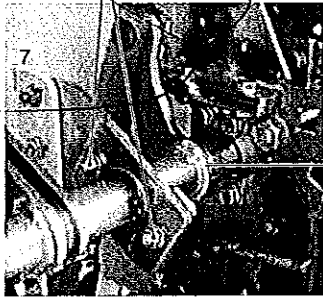

15 Nm

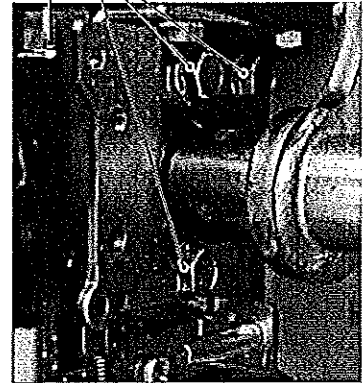

25 Nm

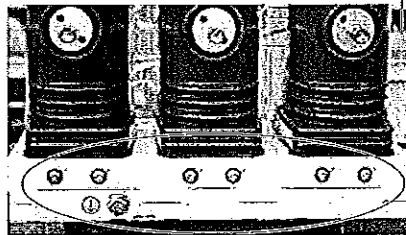
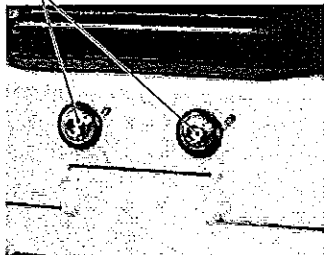

### EL Twin actuator - 50 kA

15 Nm

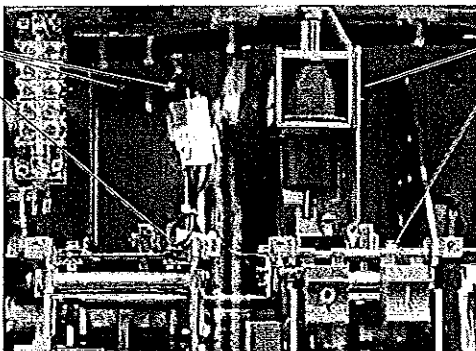

15 Nm

15 Nm

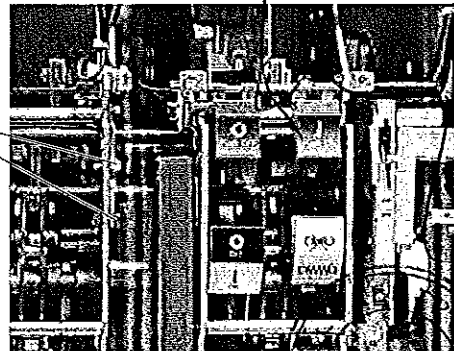
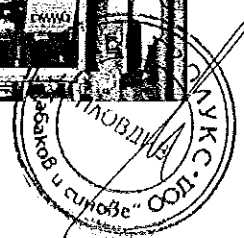

Fig. 12

ВЯРНО С ОРИГИНАЛА



### 9.2.3. Circuit-breaker pole

No other check except what has already been specified in par. 9.2.1. is necessary.

### 9.2.4. Withdrawable assembly (truck and circuit-breaker)

Visually inspect the components, especially those which may be damaged by incorrect operations (also see table in chap. 8). Visually inspect the isolating contacts and that all the contact elements are clean, especially in cases where signs of overheating are found (also see par. 9.4.). Visually inspect and carry out the functional tests of the locks, checking their correct operation and activation without abnormal force – maximum 25 N (also see table in chap. 8).

## 9.3. Overhauling

### 9.3.1. Interruption devices in general

Should it have been necessary to clean the devices during the inspections, according to what is specified in par. 9.2.1., use the following procedure:

- insulate the work area and make it safe, following the safety regulations specified in the IEC/DIN VDE Standards;
- general cleaning of the surfaces:
  - dry and eliminate light deposits of dirt with a soft dry cloth;
  - more resistant deposits of dirt can be removed using slightly alkaline domestic type detergent or Rivolta BWR 210 type detergent;
- cleaning insulating surfaces and conductive parts:
  - light dirt: with Rivolta BWR 210 detergent;
  - resistant dirt: with cold detergent type 716.

After cleaning, rinse thoroughly with clean water and dry carefully.

#### Note

Only use detergents without halogens and never 1.1.1-trichloroethane, trichloroethylene or carbon tetrachloride!

### 9.3.2. Tripping device: actuator and transmission system

**Circuit-breakers up to 17.5 kV, 2500 A, 31.5 kA and up to 24 kV, 2500 A, 25 kA**

To ensure correct operation of the circuit-breaker, inspection and maintenance of the tripping devices is recommended every 10,000 operations. For this purpose, please contact the ABB Service office.

Complete replacement of the actuator, shock absorber and of the other transmission system parts (shaft, main levers, safety rings, etc.) must be carried out after 30,000 operations.

**Circuit-breakers up to 17.5 kV, 40 kA and 24 kV, 31.5 kA**

To ensure correct operation of the circuit-breaker, inspection and maintenance of the tripping devices is recommended every 10,000 operations. For this purpose, please contact the ABB Service office.

Complete replacement of the actuator must be carried out every 10,000 operations.

Complete replacement of the shock absorber and of the other transmission system parts (shaft, main levers, safety rings, etc.) must be carried out after 30,000 operations.

**Circuit-breakers up to 17.5 kV, 3150 A, 40 kA**

To ensure correct operation of the circuit-breaker, inspection and maintenance of the tripping devices must be carried out every 5,000 operations. For this purpose, please contact the ABB Service office.

Complete replacement of the shock absorber and of the other part of the transmission system (shaft, main levers, safety rings, etc.) must be carried out after 10,000 operations.

**Circuit-breakers up to 17.5 kV, 50 kA and EL twin actuator**

To ensure correct operation of the circuit-breaker, inspection and maintenance of the tripping devices must be carried out every 10,000 operations. For this purpose, please contact ABB Service.

Complete replacement of the shock-absorber and of the other parts of the transmission system (shaft, main levers, safety rings, etc.) must be carried out every 10,000 operations.

#### Note

Dismantling and replacement of the operating mechanism (trip box) can only be carried out by ABB personnel or by skilled and specially trained personnel, particularly for the necessary adjustments.

### Details regarding overhauling

- When foreseen, cut of the power supply to the spring charging motor and manually discharge the operating mechanism spring by closing and opening the circuit-breaker.
- Replace the parts subjected to mechanical stress or stress due to particular environmental conditions, (contact and ABB service centre).

#### Note

These operations can only be carried out by ABB personnel or by skilled and specially trained personnel.

ВЕРНО С ОРИГИНАЛА



### 9.3.3. Circuit-breaker pole

The circuit-breaker pole and relative vacuum interrupter are maintenance-free until the maximum number of electrical operations for the type of interrupter is reached (see par. 7.2.3. Trip curves).

The operating life of the vacuum interrupter is defined by the sum of the ultimate currents corresponding to the specific type of interrupter in accordance with what is indicated in the graphs of par. 7.2.3. Trip curves; when the sum of the ultimate currents is reached, the whole pole must be replaced.

#### Note

Dismantling and replacement of the pole can only be carried out by ABB personnel or by skilled and specially trained personnel, particularly for the necessary adjustments.

To carry out the interrupter test without dismantling the circuit-breaker pole, use:

- the VIDAR vacuum tester, made by the company Programma Electric GmbH, Bad Homburg v.d.H.

To check vacuum tightness of the interrupter, the following test values must be set on the VIDAR tester:

ated voltage of the circuit-breaker	d.c. test voltage
12 kV	40 kV
17.5 kV	40 kV
24 kV - 36 kV	60 kV

The test must always be carried out with the circuit-breaker open with the contacts at the nominal distance.

Procedure for testing the degree of vacuum of the interrupter of the circuit-breaker poles:

- turn the power supply off and make the working area safe by following the safety regulations specified in the IEC/DIN VDE Standards;
- open the circuit-breaker;
- earth a terminal of each circuit-breaker pole;
- connect the earth terminal of the VIDAR tester to the circuit-breaker structure;
- connect the high voltage terminal of the VIDAR tester to the terminal of the circuit-breaker pole not connected to earth (L1 phase) and carry out the test. Repeat the test for phases L2 and L3.

#### Note

The tester connection cables can produce an indication due to the capacitive effect. In this case the cables must not be removed.

## 9.4. Repairs

Replacement of spare parts and accessories must only be carried out by ABB personnel or suitably qualified and specially trained personnel.

Always work with the circuit-breaker open and locked so that it cannot be closed again, with the work area insulated and made safe.

The operating mechanism spring must be discharged.

All power supply sources must be disconnected and made safe against any reclosing during removal and installation work.



Should maintenance be carried out by the customer's personnel, responsibility for the interventions remains with the customer.

The replacement of parts not included in the "List of spare parts/accessories" (par. 12.1.) must only be carried out by ABB personnel. In particular:

- complete pole with bushings/connections
- actuator and transmission system
- closing spring set
- opening spring
- shock-absorber.

ВРАНО С ОПИТНАНА

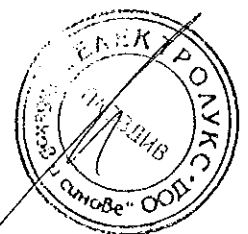

## 10. Application of the X-ray emission Standards

One of the physical properties of vacuum insulation is the possibility of X-ray emission when the interrupter contacts are open.

The specific tests carried out at the PTB laboratories (Physikalisch-Technische Bundesanstalt, in Brunswick - Germany) show that local emission at a distance of 10 cm from the interrupter or pole surface, does not exceed 1 mSv/h.

It follows that:

- at the rated service voltage the use of vacuum interrupters is absolutely safe;
- application of the withstand voltage at power frequency, according to the IEC 62271-100 and VDE 0670 Standards, is safe;
- application of a voltage higher than the withstand voltage at power frequency or of a test voltage in direct current, specified in the IEC and VDE Standards, cannot be used;
- limitation of the above-mentioned local phenomena, with interrupters with open contacts, depends on keeping the specific distance between the contacts.

This condition is intrinsically guaranteed by correct operation of the operating mechanism and by the adjustments of the transmission system.

ВЯРНО С ОРИГИНАЛА



# 11. Spare parts and accessories

 All assembly operations of spare parts/accessories must be carried out following the instructions enclosed with the spare parts, by ABB personnel or by suitably qualified customer personnel with in-depth knowledge of the apparatus (IEC 60694) and of all the Standards aimed at carrying out these interventions in safe conditions. Should the maintenance be carried out by the customer's personnel, responsibility for the interventions remains with the customer. Before carrying out any operation, always make sure that the circuit-breaker is open, the spring discharged and that it is not energised (medium voltage circuit and auxiliary circuits).

To order circuit-breaker spare parts/accessories, refer to the ordering sales codes indicated in the technical catalogue and always state the following:

- type of circuit-breaker
- rated voltage of the circuit-breaker
- rated normal current of the circuit-breaker
- breaking capacity of the circuit-breaker
- serial number of the circuit-breaker
- rated voltage of any electrical spare parts.

For availability and to order spare parts, please contact our Service office.

## 11.1. List of spare parts

- Shunt opening release
- Additional shunt opening release
- Undervoltage release
- Contact for signalling undervoltage release energised/de-energised
- Time delay device for undervoltage release
- Mechanical override for undervoltage release
- Shunt closing release
- Spring charging geared motor with electrical signalling of spring charged
- Contact signalling protection circuit-breaker of the geared motor open/closed
- Contact signalling closing spring charged/discharged
- Transient contact with momentary closing during circuit-breaker opening
- Circuit-breaker auxiliary contacts
- Locking electromagnet on the operating mechanism
- Position contact of the withdrawable truck
- Contacts signalling connected/isolated
- Opening solenoid
- Key lock in open position
- Isolation interlock with the door
- Protection for opening pushbutton
- Protection for closing pushbutton
- Locking electromagnet on the withdrawable truck
- Set of six tulip contacts.



ВЯРНО С ОПРИГНАЛА



## 12. Electric circuit diagrams

The standard VD4 circuit-breaker electric circuit diagrams are as follows:

- 1VCD400046: Fixed circuit-breakers
- 1VCD400099: Fixed circuit-breakers 50 kA
- 1VCD400055: Fixed circuit-breakers with 64-pole connector
- 1VCD400064: Fixed circuit-breakers with 58-pole connector
- 1VCD400078: Fixed circuit-breakers with truck
- 1VCD400047: Withdrawable circuit-breakers
- 1VCD400048: Withdrawable circuit-breakers with motorized truck
- 1VCD400100: Withdrawable circuit-breakers 50 kA
- 1VCD400080: Withdrawable circuit-breakers for ZS8.4 switchgear VD4/ZS8, ZT8 and Z8 with circuit-breaker
- 1VCD400080: Withdrawable circuit-breakers for ZS8.4 switchgear with VD4/ZS8, ZT8 and Z8 circuit-breaker with motorized truck
- 1VCD400102: Withdrawable circuit-breakers with motorized truck 50 kA.

Each circuit-breaker is always provided with the standard electric diagram or with a specific diagram in the case of a circuit-breaker with non-standard cabling.

ВЯРНО С ОРИГИНАЛА

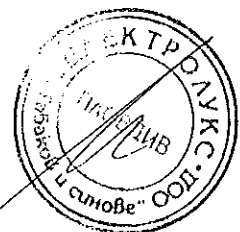



# 13. Overall dimensions

## Fixed circuit-breakers

VD4		
TN	1VCD000050	
Ur	12	kV
	17.5	kV
Ir	1600 A	
Isc	20	kA
	25	kA
	31.5	kA

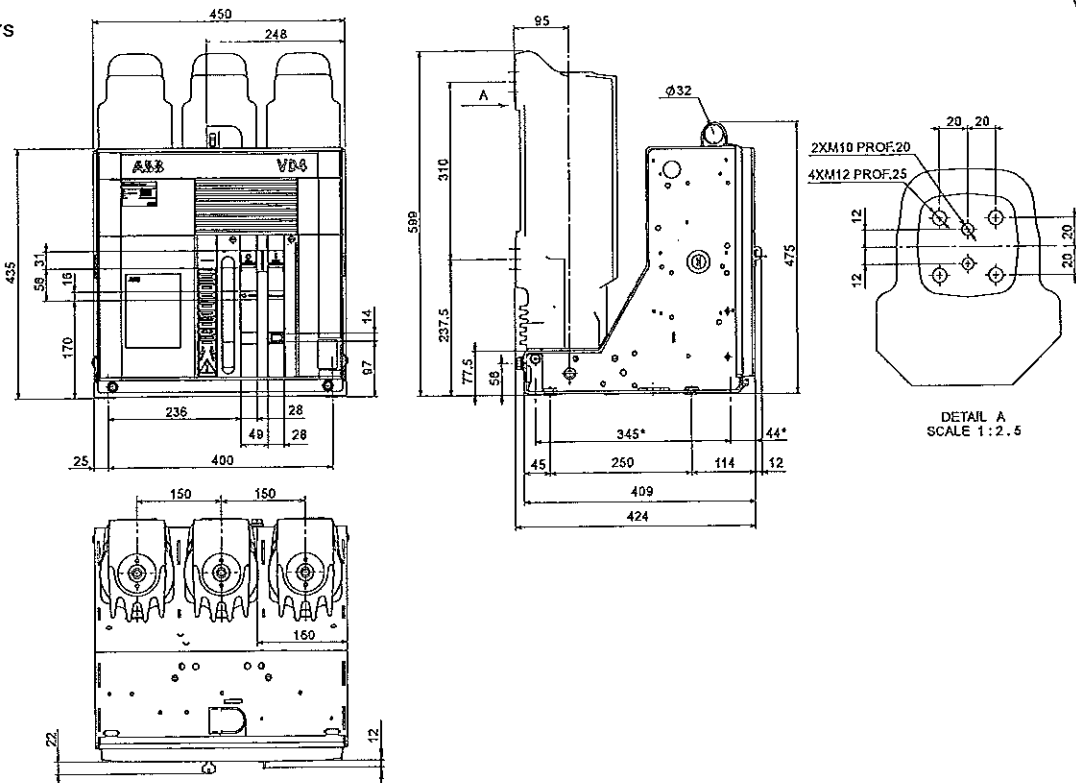

(\*) Fixing interchangeability with previous series (345 x 400).

## Fixed circuit-breakers

VD4		
TN	7405	
Ur	12	kV
	17.5	kV
Ir	630 A	
	1250	A
Isc	16	kA
	20	kA
	25	kA
	31.5	kA

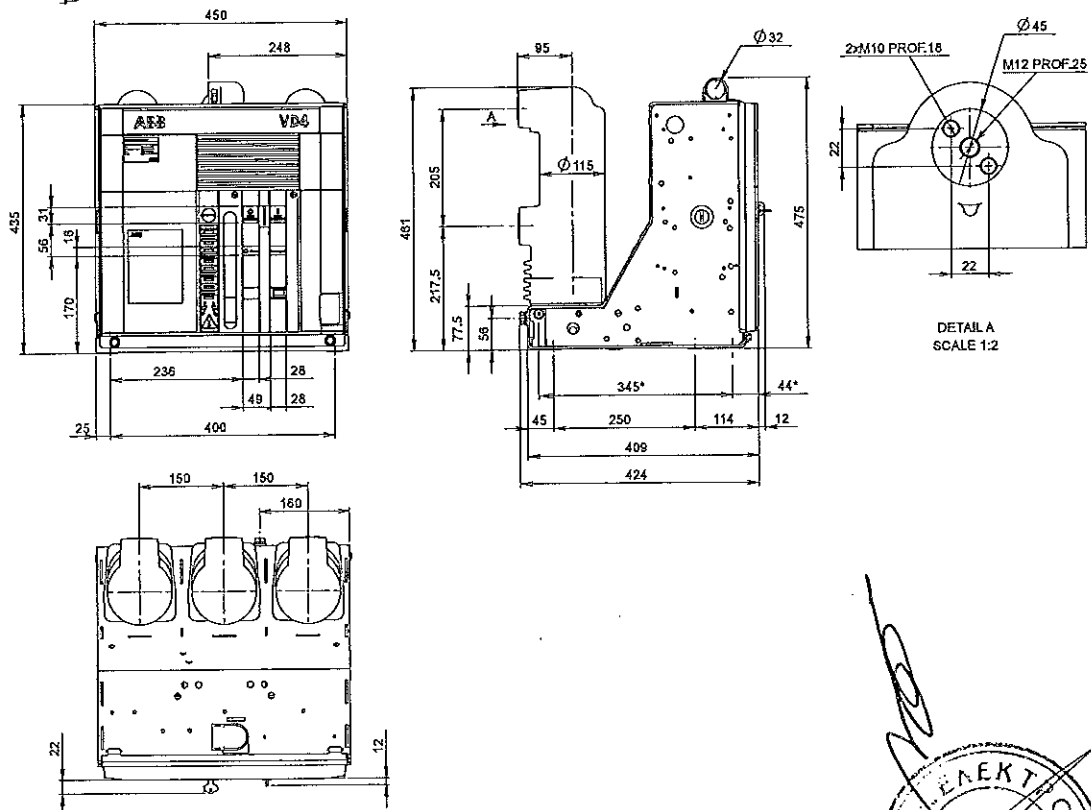

(\*) Fixing interchangeability with previous series (345 x 400).

**ВЕРНО С ОРИГИНАЛА**



Fixed circuit-breakers

VD4	
TN	7406
Ur	12 kV
	17.5 kV
Ir	630 A
	1250 A
Isc	16 kA
	20 kA
	25 kA
	31.5 kA

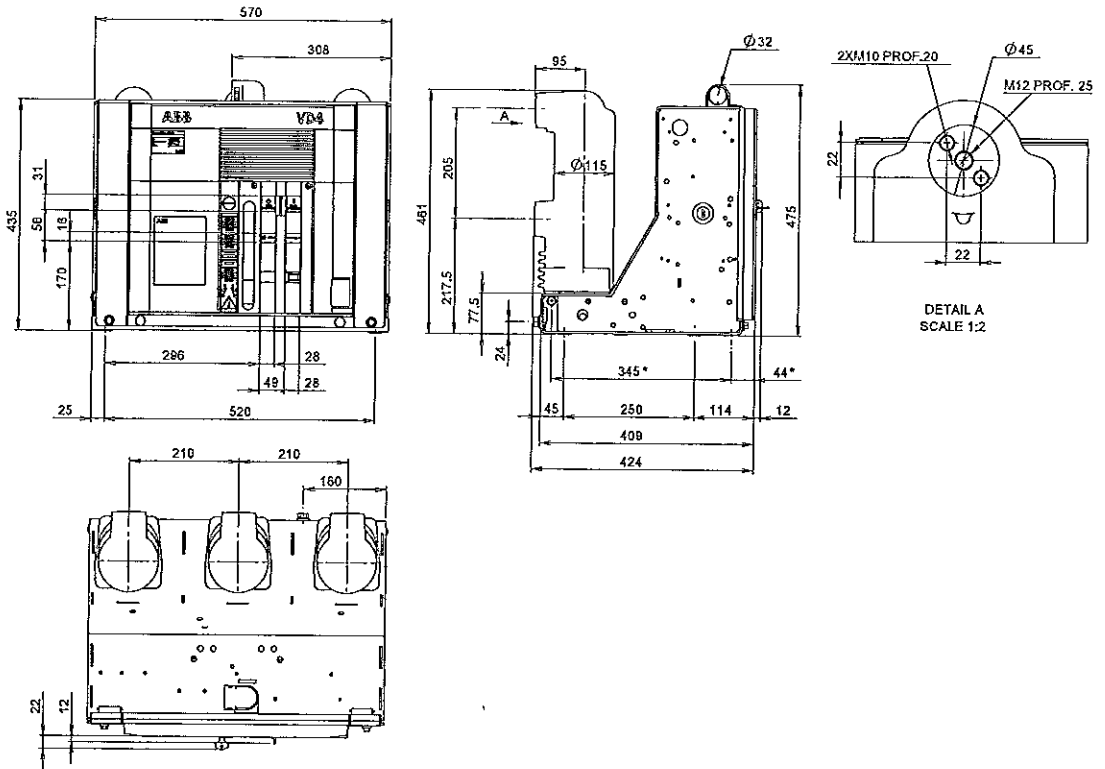

(\*) Fixing interchangeability with previous series (345 x 520).

Fixed circuit-breakers

VD4	
TN	1VCD003282
Ur	12 kV
	17.5 kV
Ir	1250 A
	1600 A
Isc	40 kA

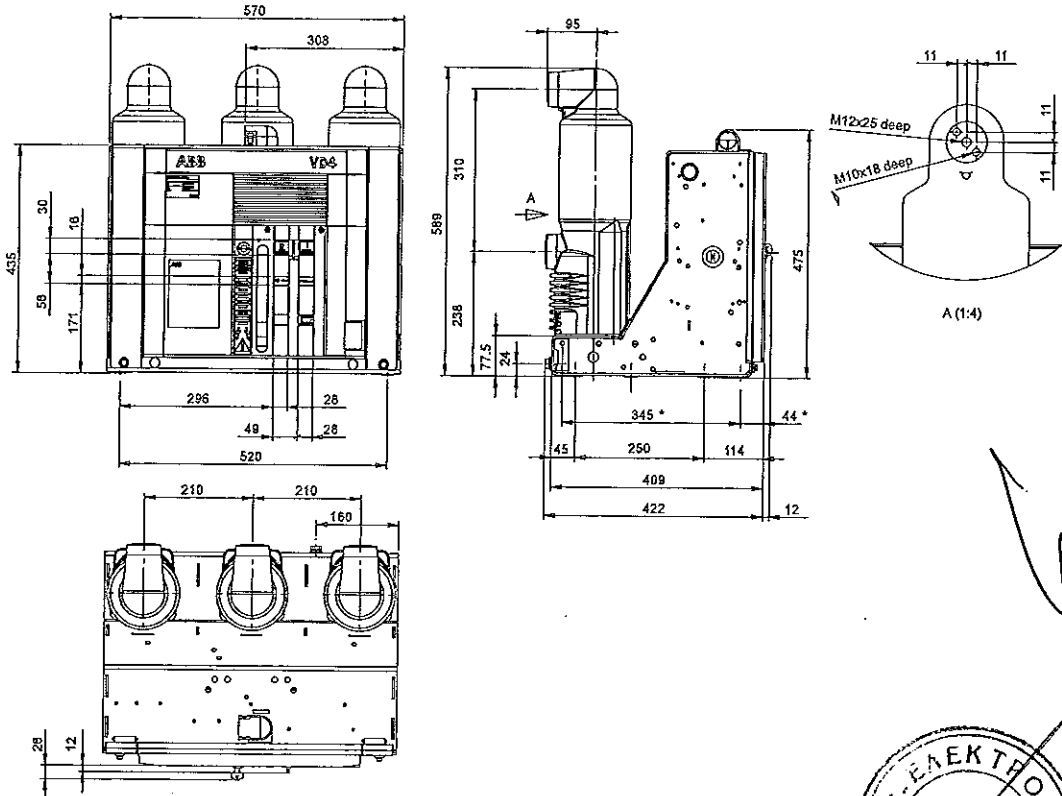

(\*) Fixing interchangeability with previous series (345 x 650).

ВЯРНО С ОРИГИНАЛА

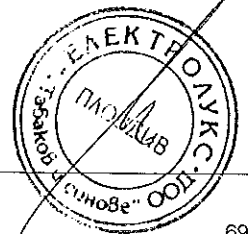

Fixed circuit-breakers

VD4	
TN	1VCD003285
Ur	12 kV
	17.5 kV
Ir	1250 A
	1600 A
Isc	40 kA

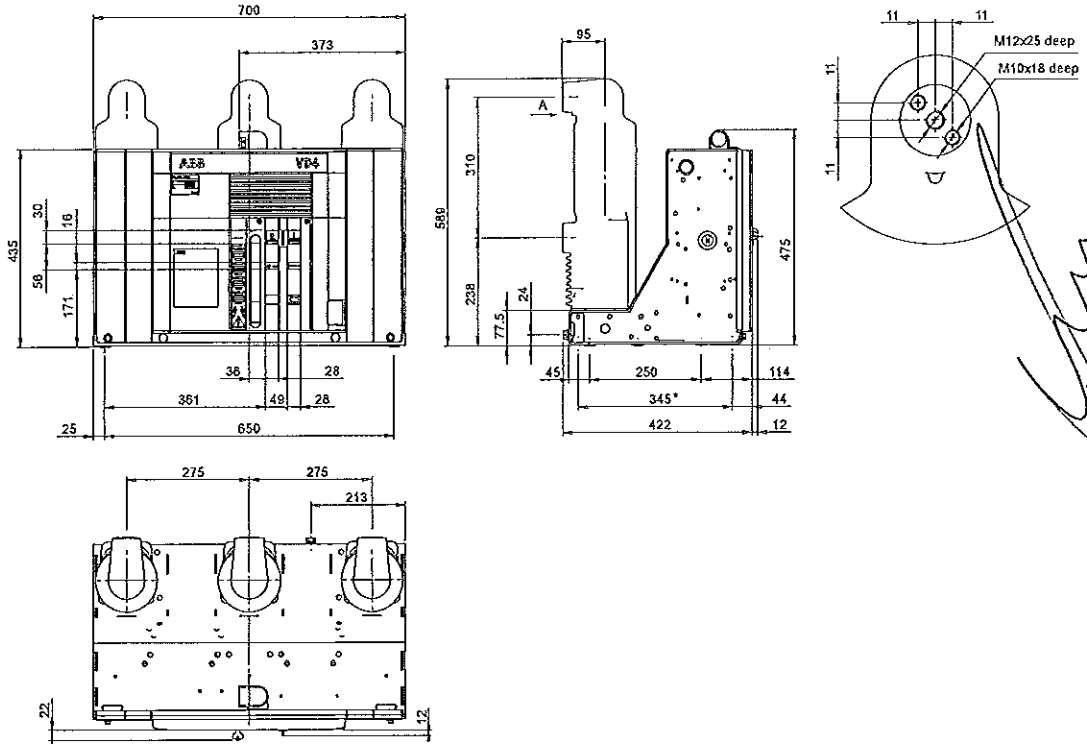

(\*) Fixing interchangeability with previous series (345 x 650).

Fixed circuit-breakers

VD4	
TN	1VCD000051
Ur	12 kV
	17.5 kV
Ir	630 A
	1250 A
Isc	16 kA
	20 kA
	25 kA
	31.5 kA

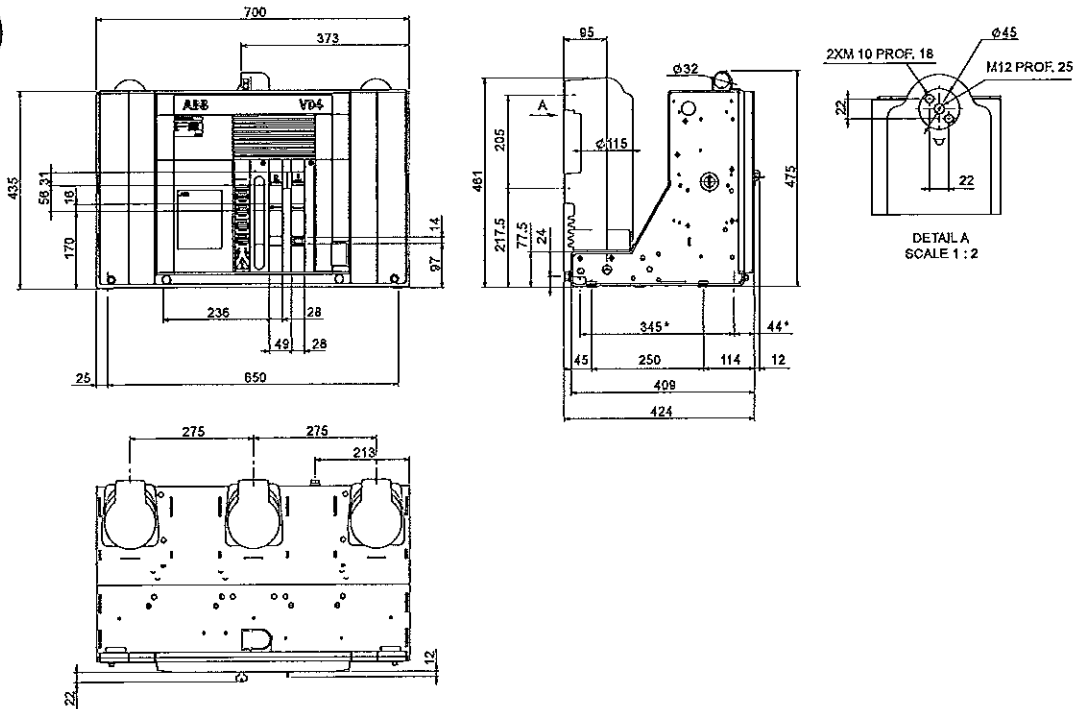

(\*) Fixing interchangeability with previous series (345 x 650).

**ВЯРНО С ОРИГИНАЛА**





Fixed circuit-breakers

VD4	
TN	1VCD000149
Ur	12 kV
	17.5 kV
Ir	3150 A
	4000 A (**)
Isc	20 kA
	25 kA
	31.5 kA
	40 kA
	50 kA

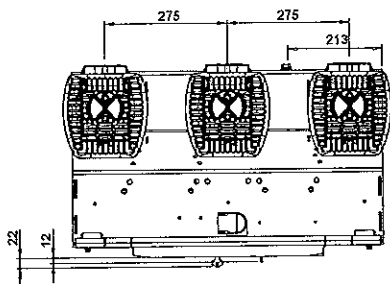
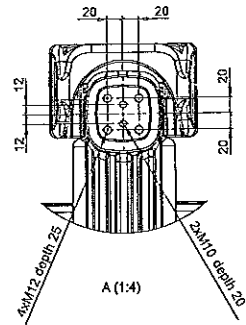
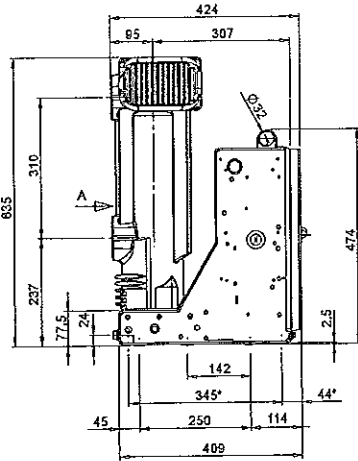
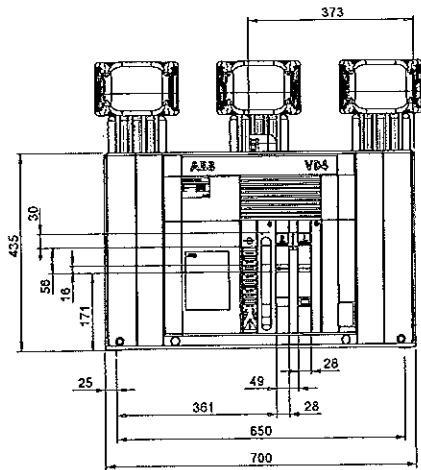

(\*) Fixing interchangeability with previous series (345 x 650).  
 (\*\*) With forced ventilation.

Fixed circuit-breakers

VD4	
TN	1VCD003440
Ur	12 kV
	17.5 kV
Ir	1250 A
	1600 A
	2000 A
Isc	50 kA

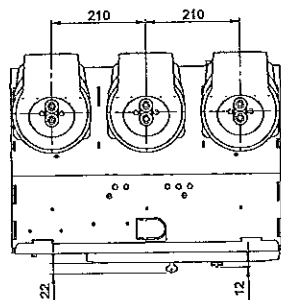
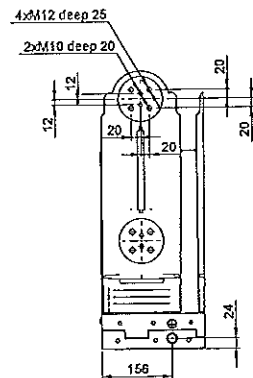
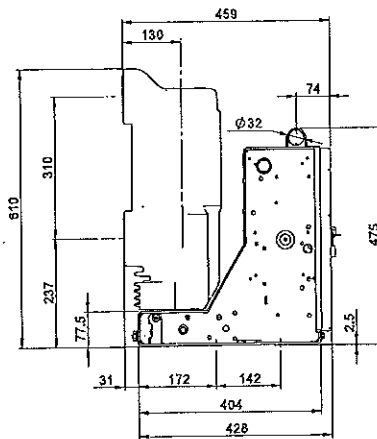
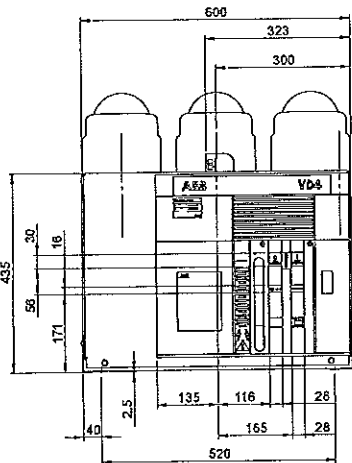

ВРЯНО С ОРИГИНАЛА



Fixed circuit-breakers

VD4	
TN	1VCD003441
Ur	12 kV
	17.5 kV
Ir	1250 A
	1600 A
	2000 A
	2500 A
Isc	50 kA

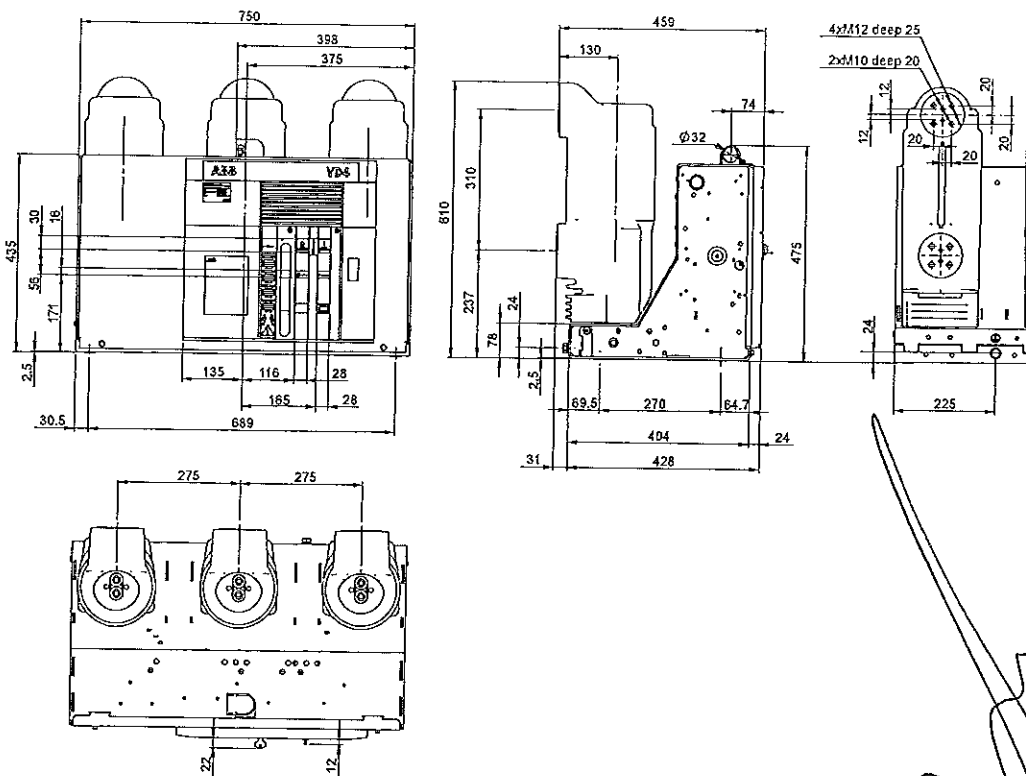

Fixed circuit-breakers

VD4	
TN	1VCD003443
Ur	12 kV
	17.5 kV
Ir	3150 A (*)
Isc	50 kA

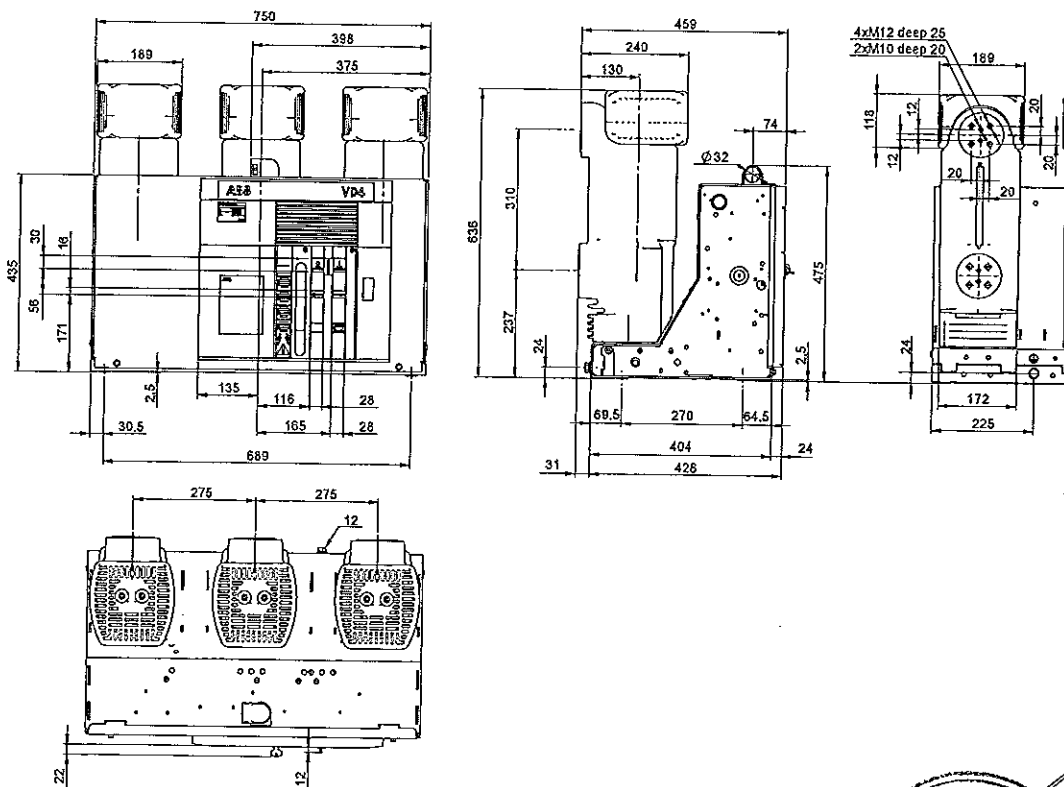

(\*) 4000 A with forced ventilation.

ВЯРНО С ОПРИТНАВА



Fixed circuit-breakers

VD4	
TN	7409
Ur	24 kV
Ir	630 A
	1250 A
Isc	16 kA
	20 kA
	25 kA

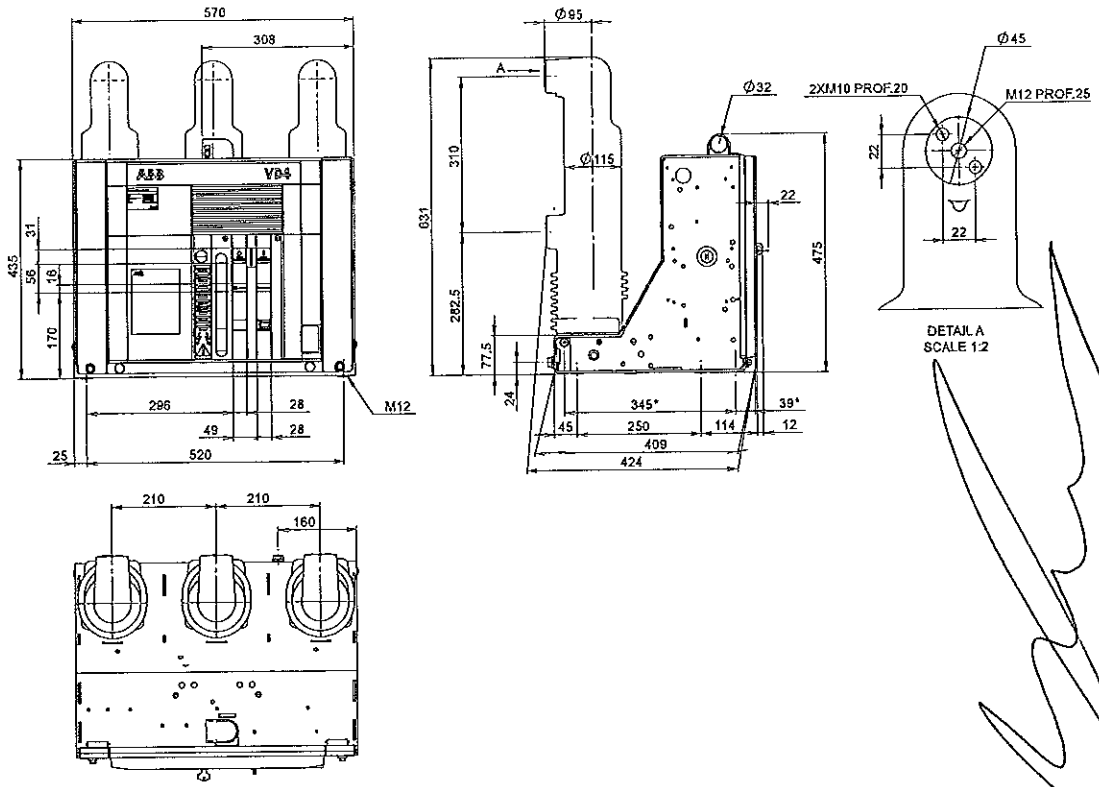

(\*) Fixing interchangeability with previous series (345 x 520).

Fixed circuit-breakers

VD4	
TN	7410
Ur	24 kV
Ir	630 A
	1250 A
Isc	16 kA
	20 kA
	25 kA

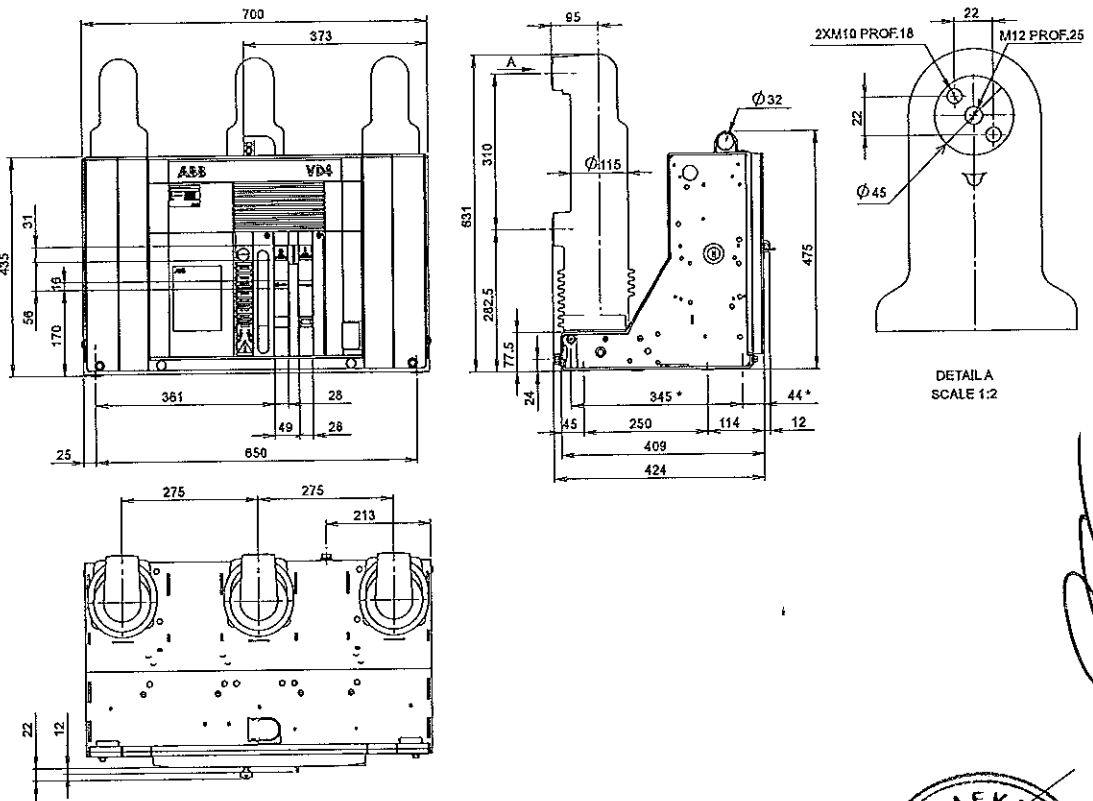

(\*) Fixing interchangeability with previous series (345 x 650).

**ВЪРНО С ОПРИГИНАЛА**



Fixed circuit-breakers

VD4		
TN	7411	
Ur	24	kV
Ir	1600	A
	2000	A
	2500	A
Isc	16	kA
	20	kA
	25	kA
	31,5	kA

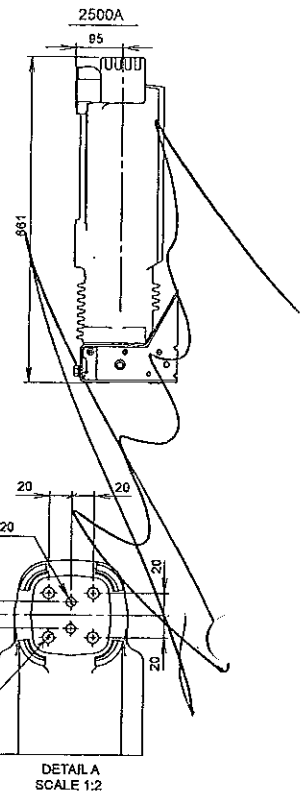
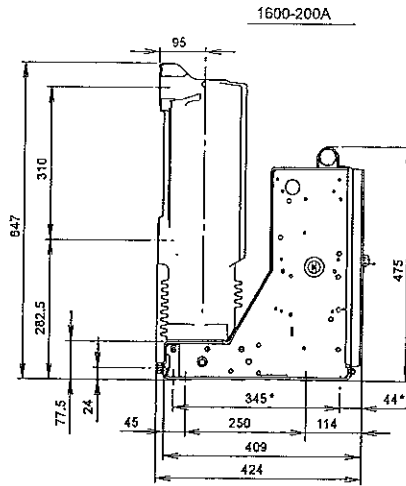
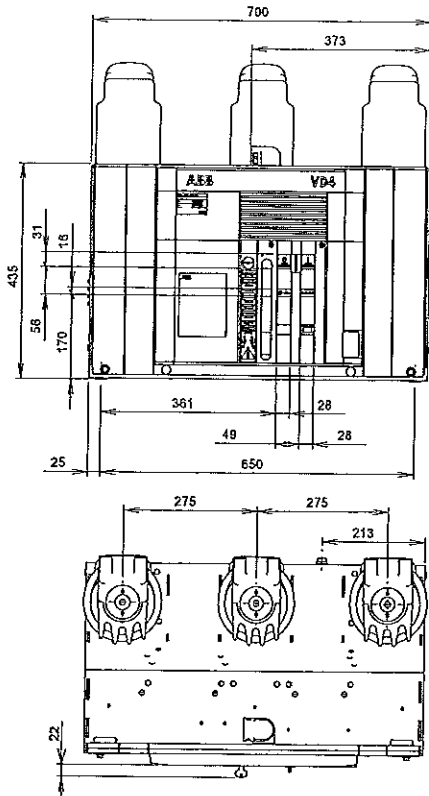

(\*) Fixing interchangeability with previous series (345 x 650).

Fixed circuit-breakers

VD4		
TN	1VCD000172	
Ur	24	kV
Ir	1250	A
Isc	31,5	kA

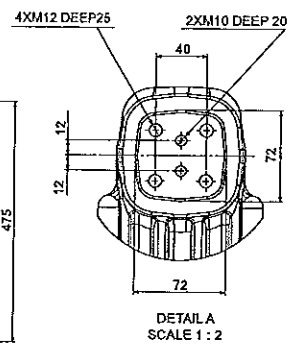
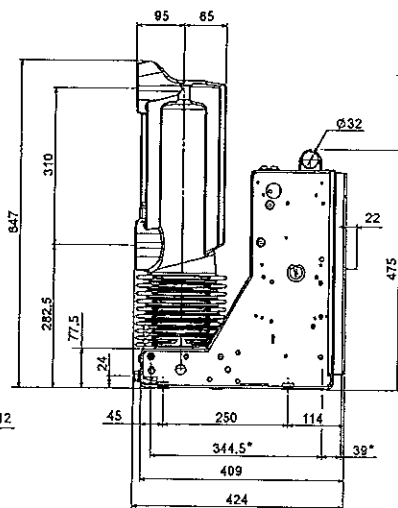
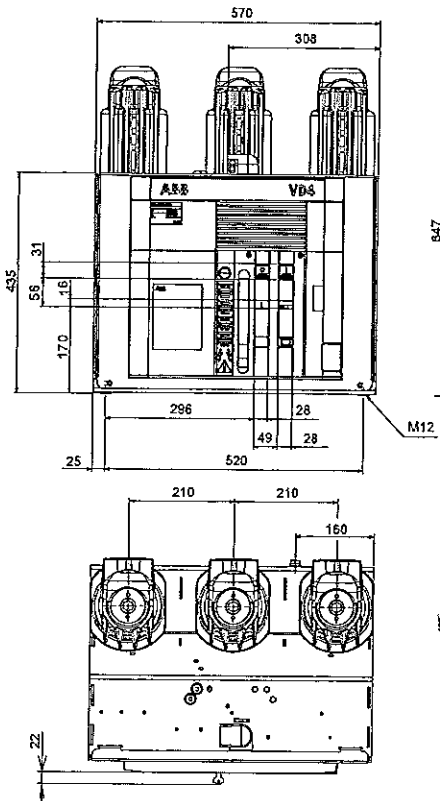

ВАРНО С ОРИГИНАЛА





Fixed circuit-breakers

VD4	
TN	1VYN300901-LT
Ur	36 kV
	1250 A
Ir	1600 A
	2000 A
Isc	31.5 kA

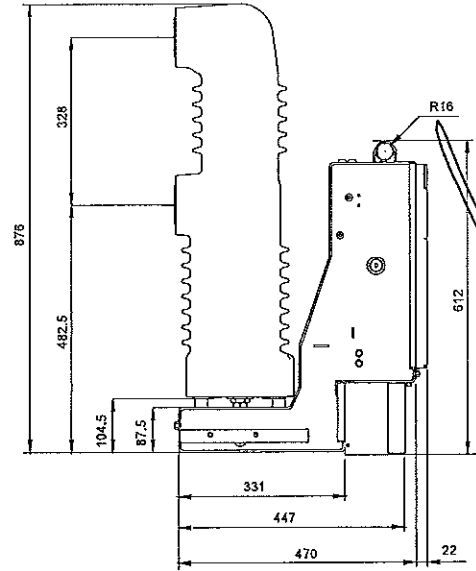
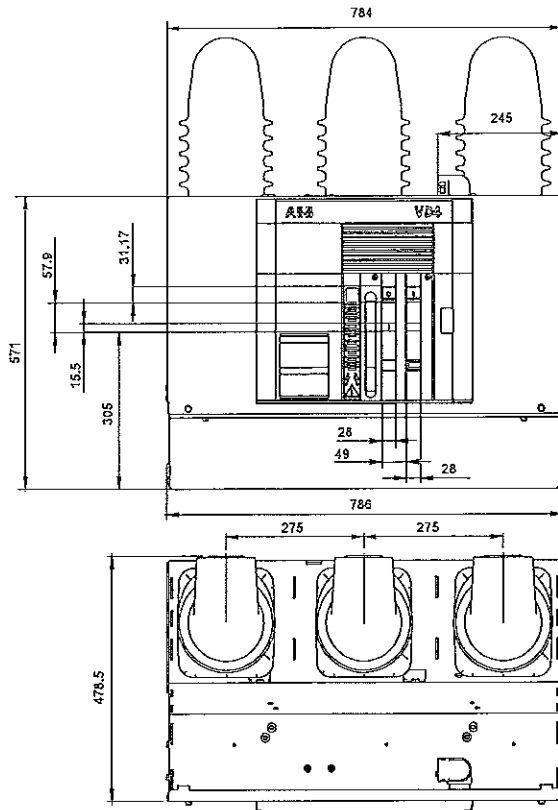

ВЯРНО С ОРИГИНАЛА



Withdrawable circuit-breakers for UniGear ZS1 switchgear and PowerCube modules

VD4/P	
TN	7412
Ur	12 kV
	17.5 kV
Ir	630 A
	1250 A
Isc	16 kA
	20 kA
	31.5 kA

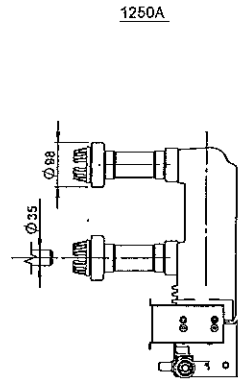
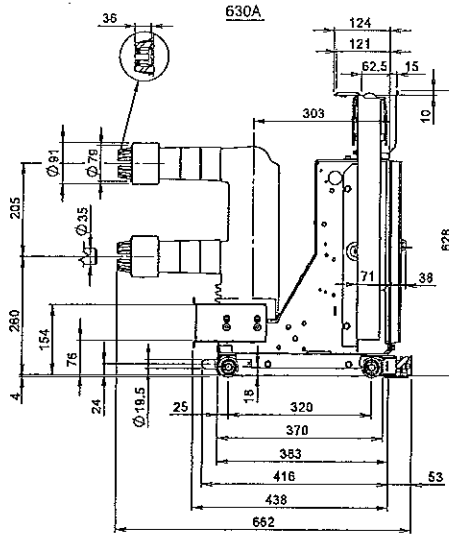
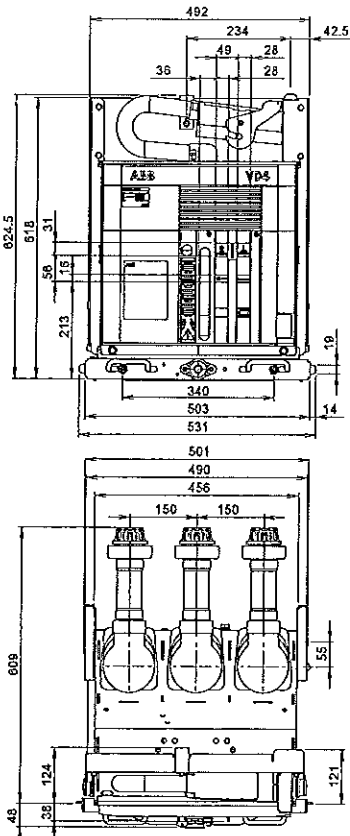

Withdrawable circuit-breakers for PowerCube modules

VD4/W	
TN	7420
Ur	12 kV
	17.5 kV
Ir	630 A
	1250 A
Isc	16 kA
	25 kA
	31.5 kA

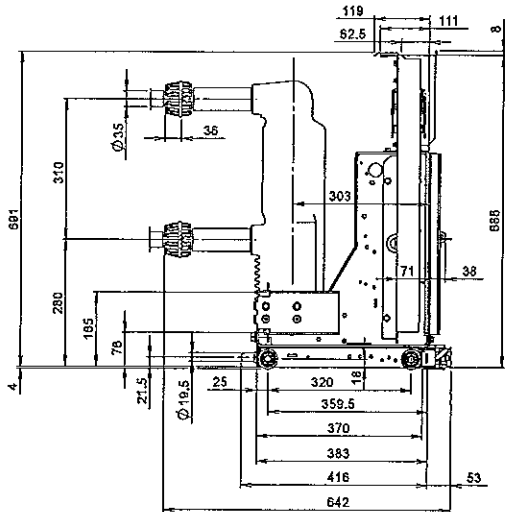
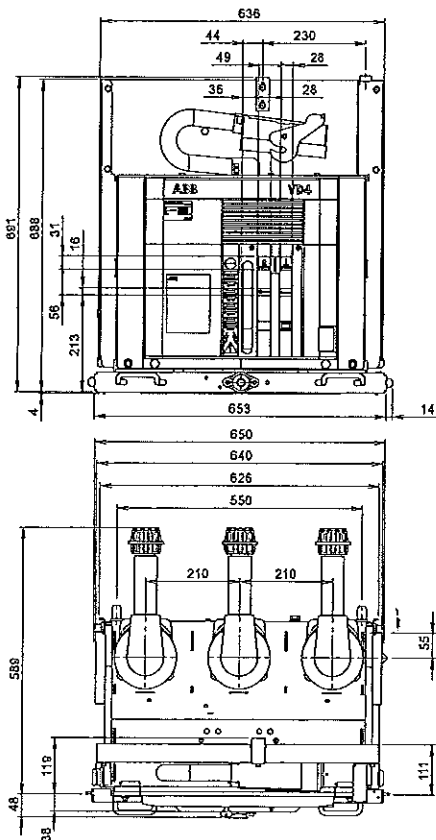

ВЕРНО С ОРИГИНАЛА

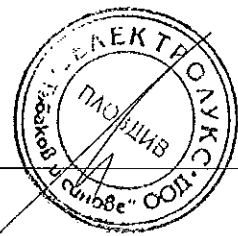

Withdrawable circuit-breakers for UniGear ZS1 switchgear and PowerCube modules

VD4/P	
TN	1VCD003284
Ur	12 kV
	17.5 kV
Ir	1250 A
	1600 A
Isc	40 kA

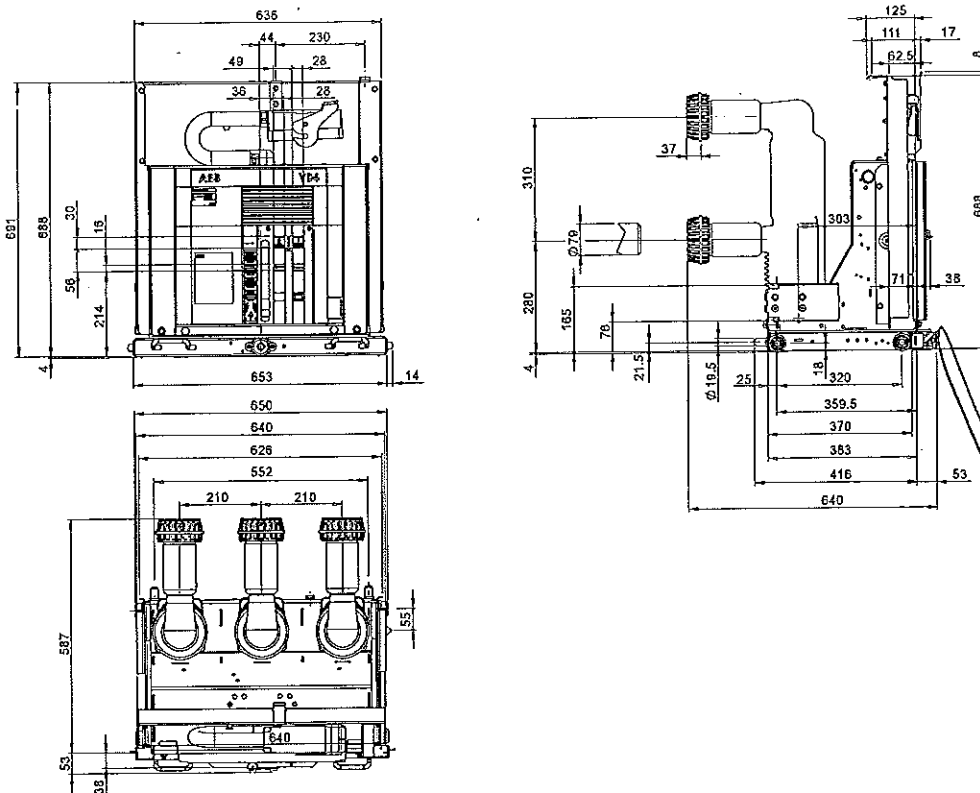

Withdrawable circuit-breakers for UniGear ZS1 switchgear and PowerCube modules

VD4/P	
TN	1VCD003286
Ur	12 kV
	17.5 kV
Ir	1250 A
	1600 A
Isc	40 kA

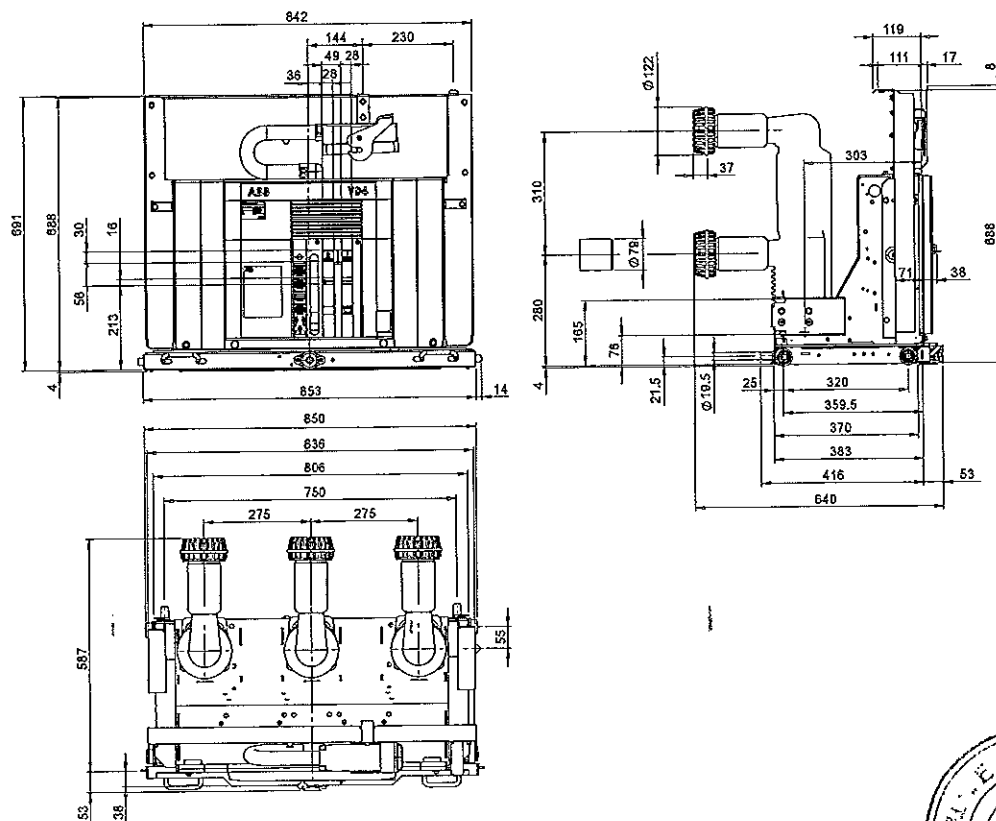

ВЯРНО С ОРИГИНАЛА



Withdrawable circuit-breakers for UniGear ZS1 switchgear and PowerCube modules

VD4/P	
TN	7415
Ur	12 kV
	17.5 kV
Ir	1600 A
	2000 A
Isc	20 kA
	31.5 kA

VD4/P	
TN	7415
Ur	12 kV
	17.5 kV
Ir	2000 A
	40 kA

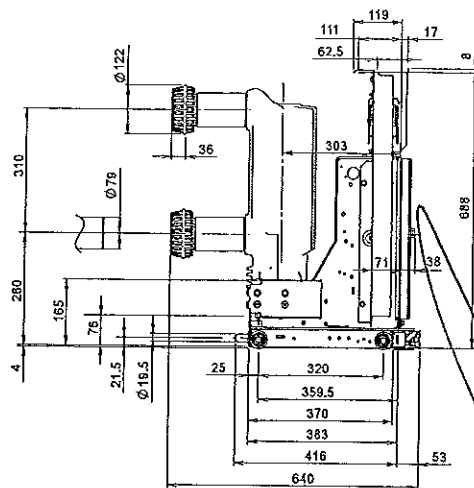
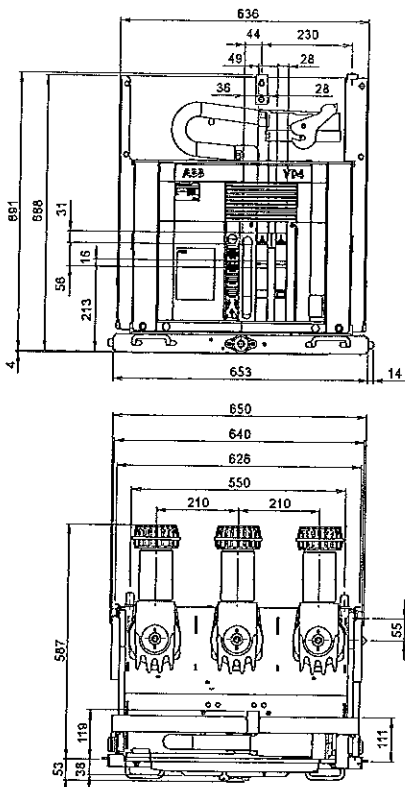

Withdrawable circuit-breakers for UniGear ZS1 switchgear and PowerCube modules

VD4/P	
TN	7416
Ur	12 kV
	17.5 kV
Ir	1600 A
	2000 A
Isc	20 kA
	31.5 kA

VD4/P	
TN	7416
Ur	12 kV
	17.5 kV
Ir	2000 A
	40 kA

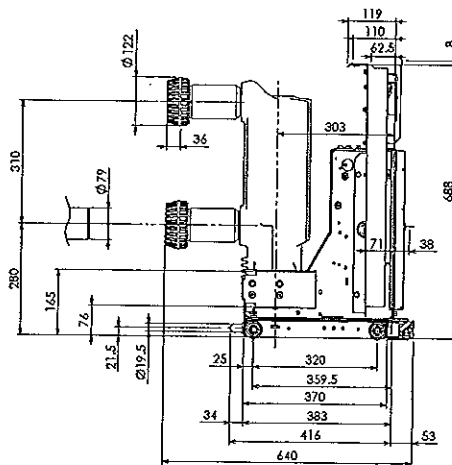
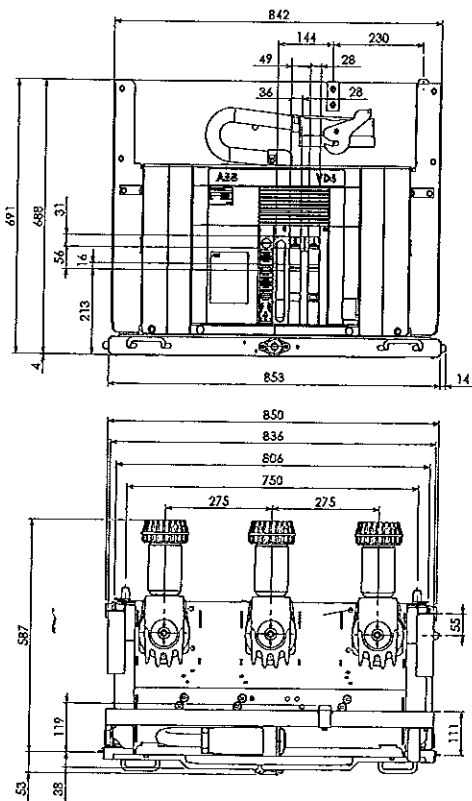

ВЕРНО С ОРИГИНАЛОМ



Withdrawable circuit-breakers for UniGear ZS1 switchgear and PowerCube modules

VD4/P	
TN	7417
Ur	12 kV
	17.5 kV
Ir	2500 A
	20 kA
Isc	25 kA
	31.5 kA
	40 kA

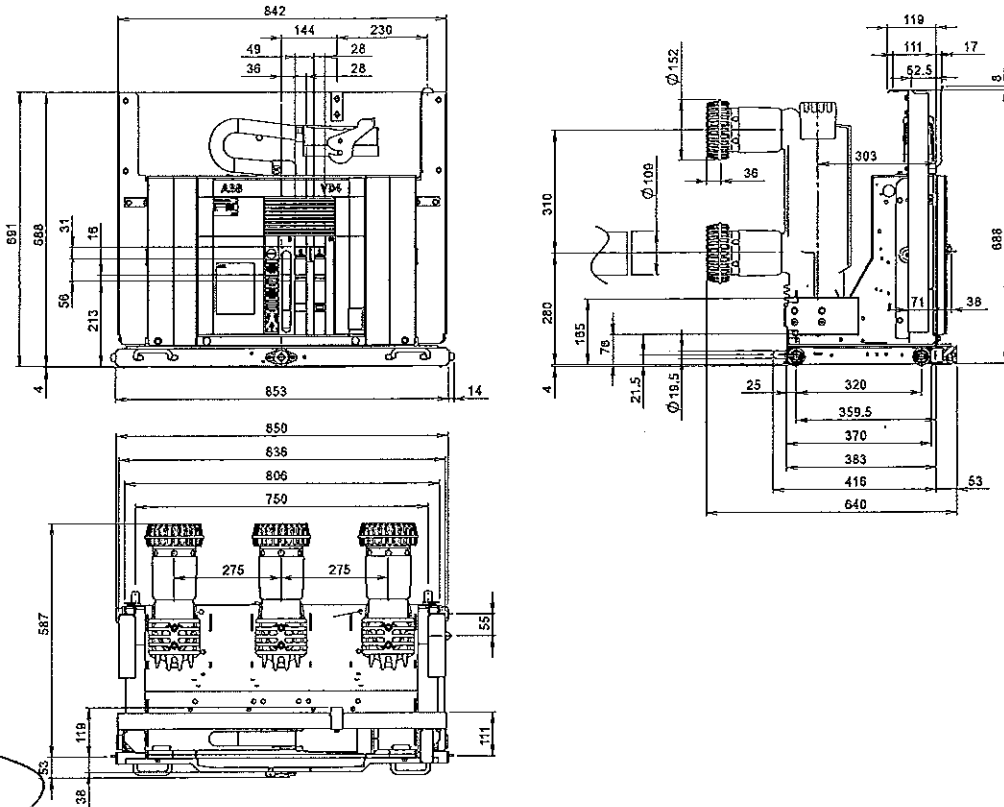

Withdrawable circuit-breakers for UniGear ZS1 switchgear and PowerCube modules

VD4/P	
TN	1VCD003444
Ur	12 kV
	17.5 kV
Ir	1250 A
	1600 A
Isc	2000 A
	50 kA

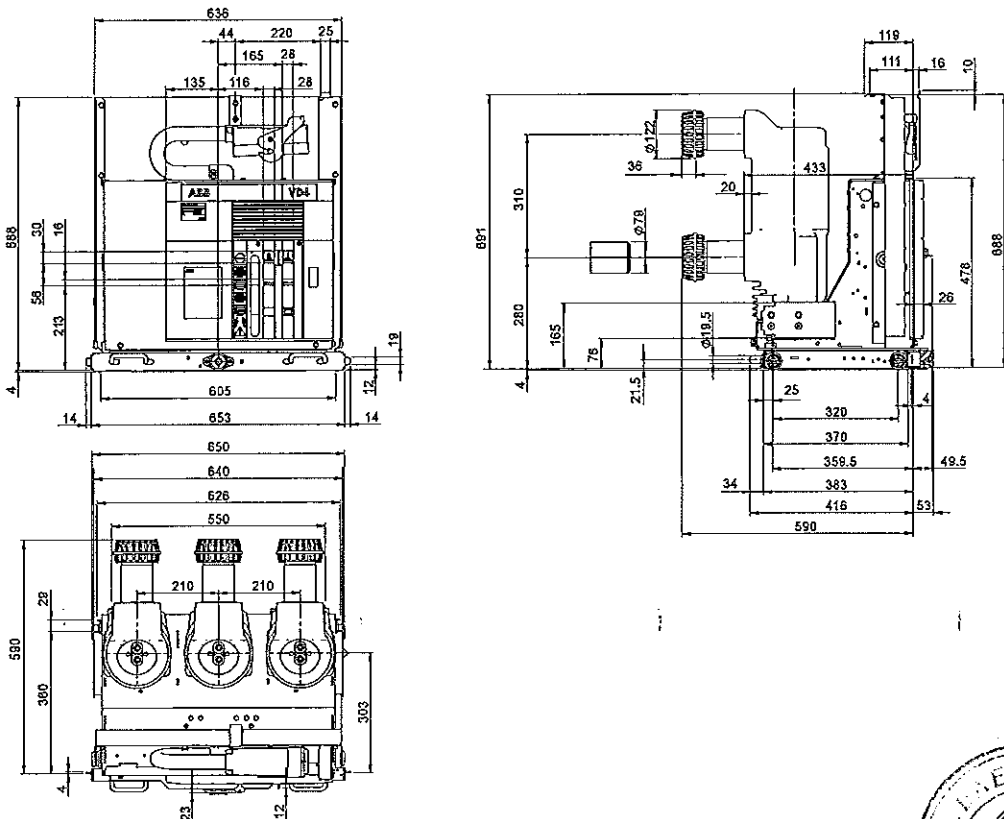

ВЕРНО С ОРИГИНАЛОМ



Withdrawable circuit-breakers for UniGear ZS1 switchgear and PowerCube modules

VD4/P	
TN	1VCD003445
Ur	12 kV
	17.5 kV
Ir	1600 A
	2000 A
Isc	50 kA

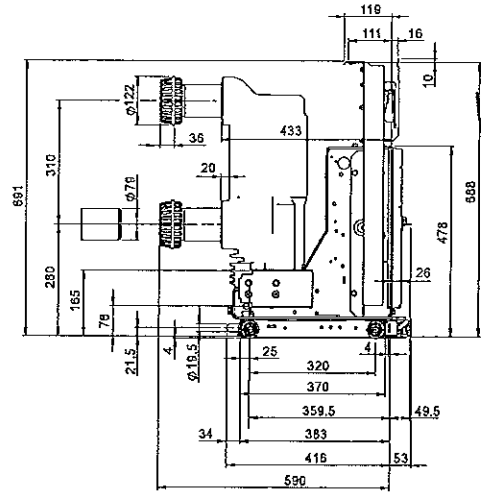
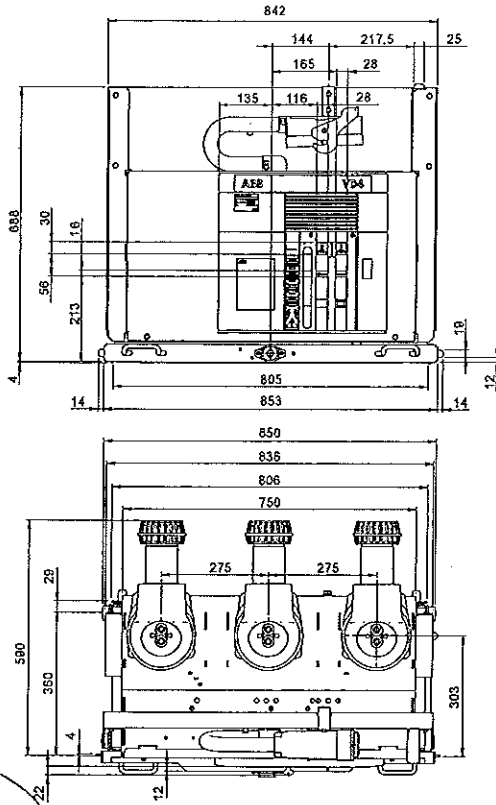

Withdrawable circuit-breakers for UniGear ZS1 switchgear and PowerCube modules

VD4/P	
TN	1VCD003446
Ur	12 kV
	17.5 kV
Ir	2500 A
Isc	50 kA

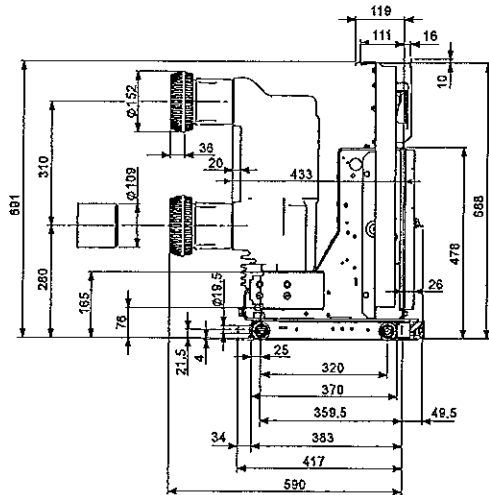
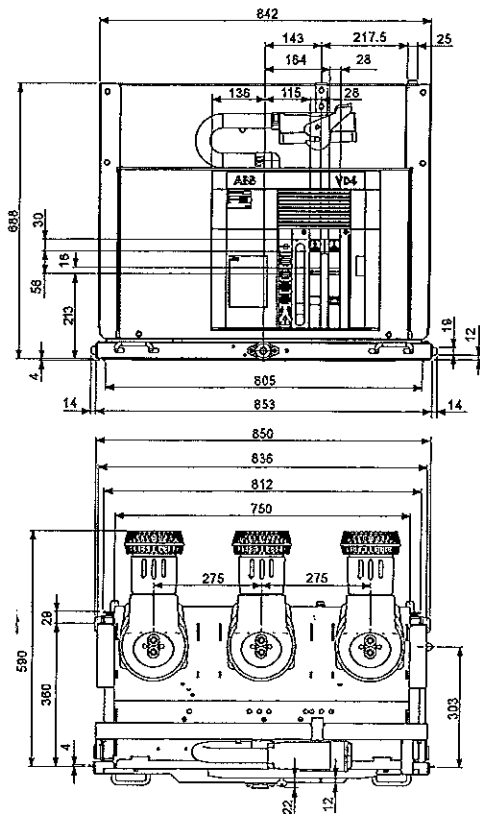

ВЯРНО С ОРИГИНАЛА



Withdrawable circuit-breakers for PowerCube modules

VD4/W	
TN	1VCD003596
Ur	12 kV
	17.5 kV
Ir	3150 A (*)
Isc	50 kA

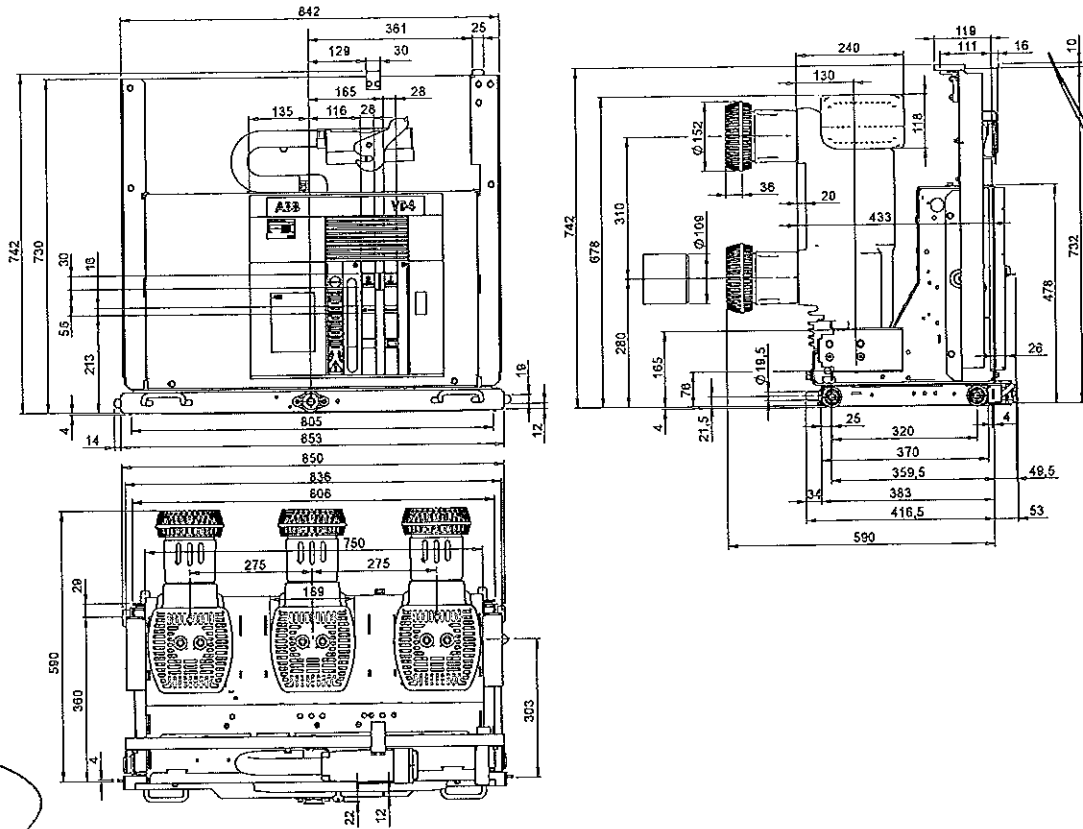

(\*) 4000 A with forced ventilation.

Withdrawable circuit-breakers for UniGear ZS1 switchgear

VD4/P	
TN	1VCD003447
Ur	12 kV
	17.5 kV
Ir	3150 A (*)
Isc	50 kA

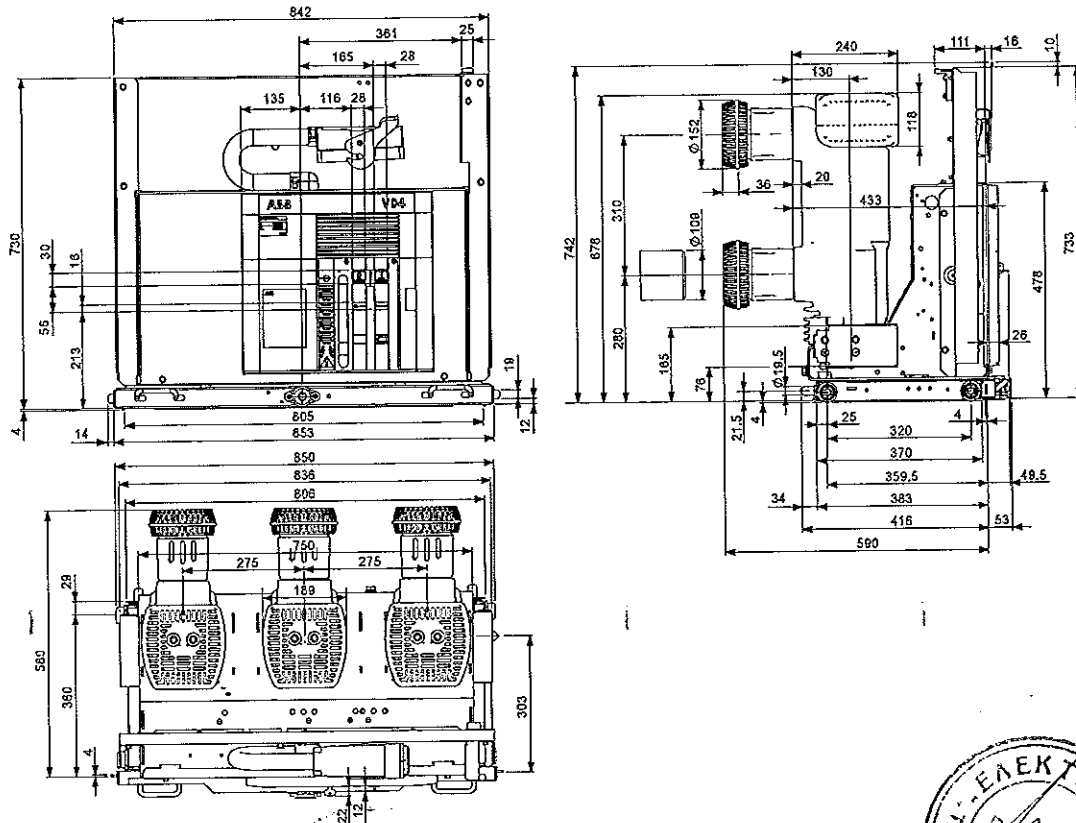

(\*) 4000 A with forced ventilation.

ВЯРНО С ОРИГИНАЛА



Withdrawable circuit-breakers for UniGear ZS1 switchgear

VD4/P	
TN	1VCD000153
Ur	12 kV
	17.5 kV
Ir	3150 A (*)
	20 kA
Isc	25 kA
	31.5 kA
	40 kA

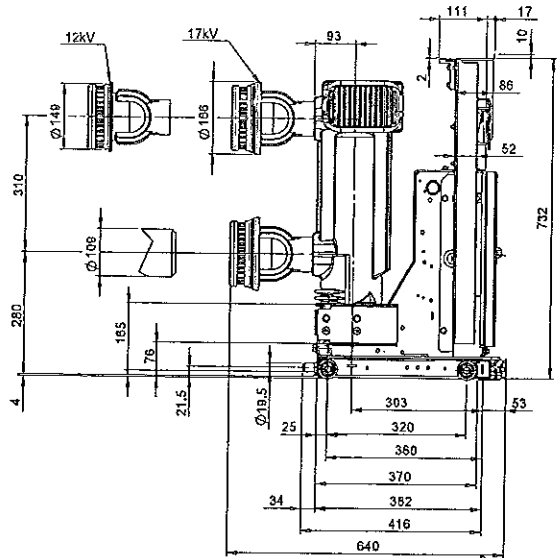
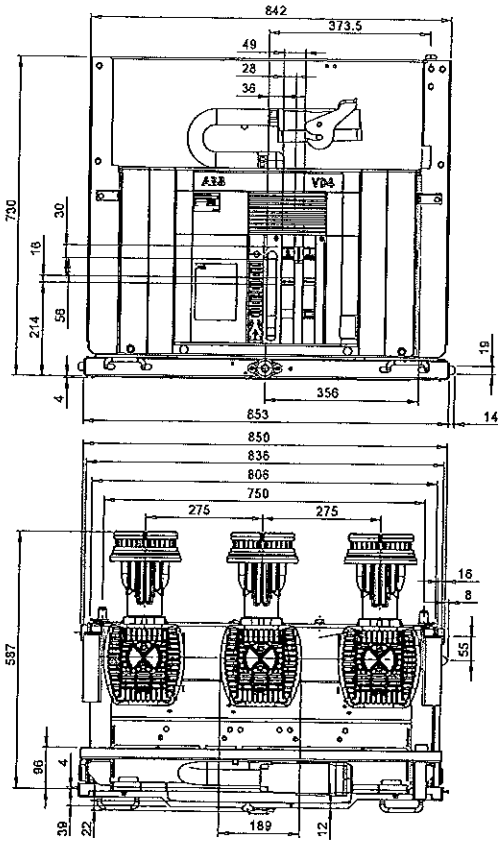

(\*) 4000 A with forced ventilation.

Withdrawable circuit-breakers for UniGear ZS1 switchgear and PowerCube modules

VD4/P	
TN	7413
Ur	24 kV
	630 A
Ir	1250 A
	16 kA
Isc	20 kA
	25 kA

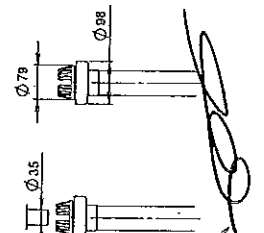
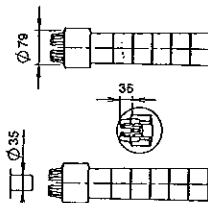
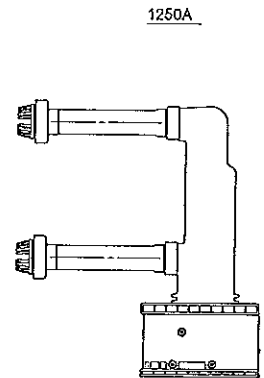
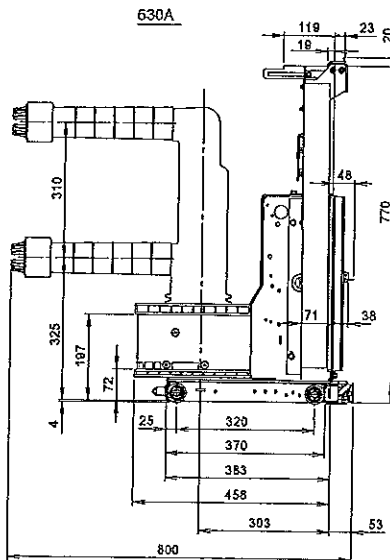
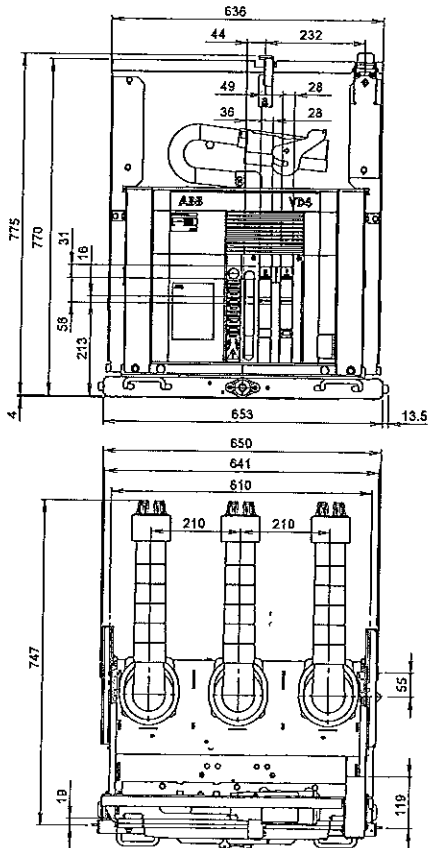

ВЕРНО С ОРИГИНАЛА





Withdrawable circuit-breakers for UniGear ZS1 switchgear

VD4/P	
TN	7414
Ur	24 kV
Ir	630 A
	1250 A
Isc	16 kA
	20 kA
	25 kA

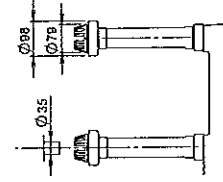
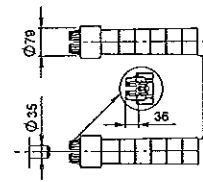
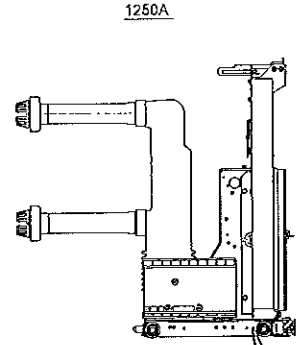
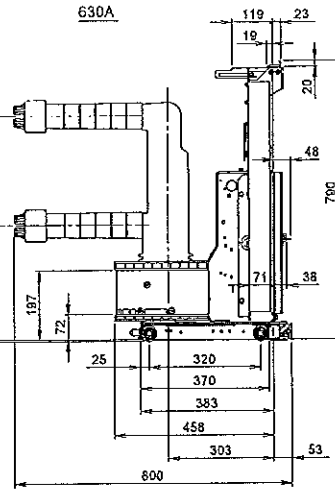
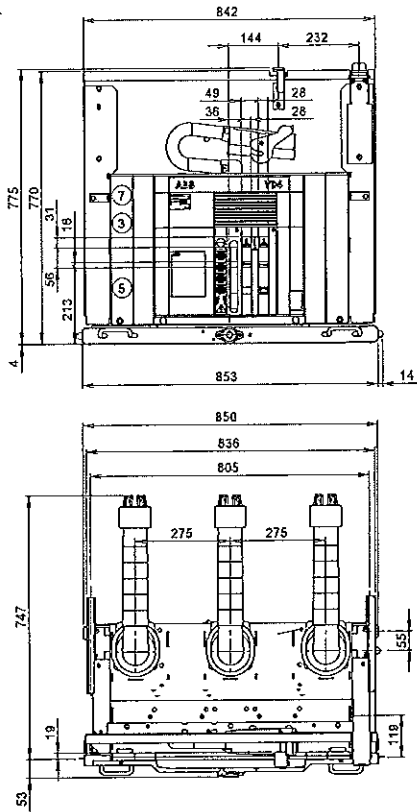

Withdrawable circuit-breakers for UniGear ZS1 switchgear

VD4/P	
TN	7418
Ur	24 kV
Ir	1600 A
	2000 A
	2500 A <sup>(1)</sup>
Isc	16 kA
	20 kA
	25 kA
	31.5 kA

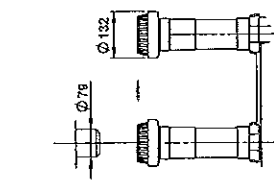
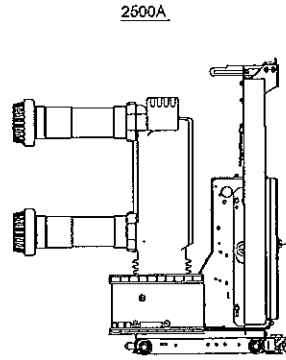
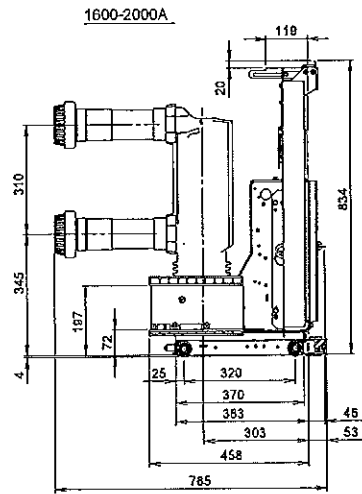
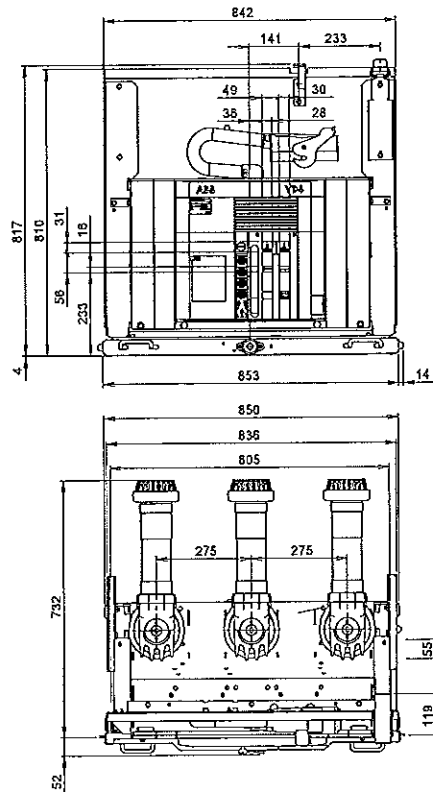

(1) The rated uninterrupted current of 2300 A is guaranteed with natural ventilation. The rated uninterrupted current of 2500 A is guaranteed with forced ventilation.

ВЯРНО С ОРИГИНАЛА

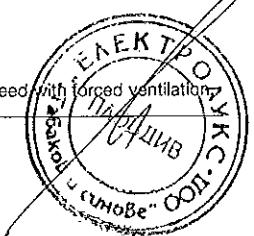

Withdrawable circuit-breakers for UniGear ZS1 switchgear

VD4/P	
TN	1VCD000173
Ur	24 kV
Ir	1250 A
Isc	31.5 kA

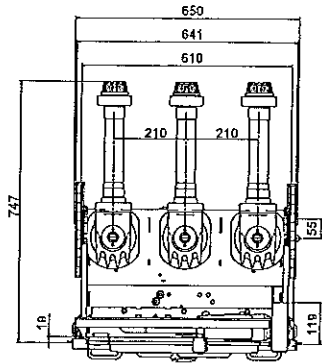
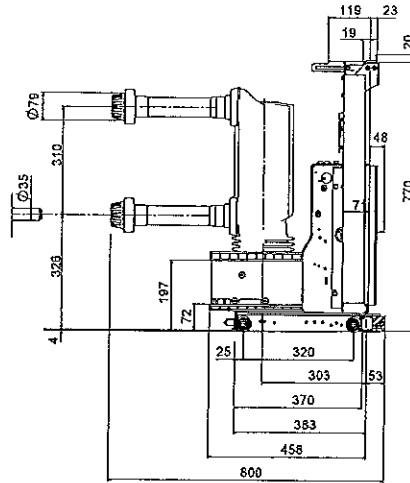
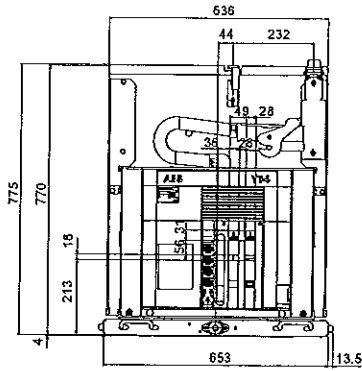

Withdrawable circuit-breakers for UniGear ZS1 switchgear

VD4/P	
TN	1VCD000177
Ur	24 kV
Ir	2700 A
	3150 A
Isc	31.5 kA

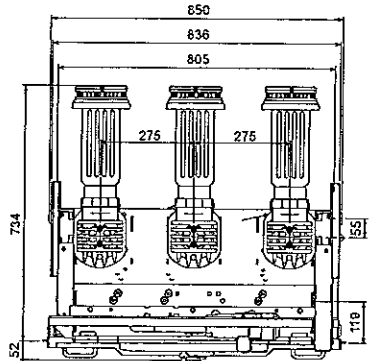
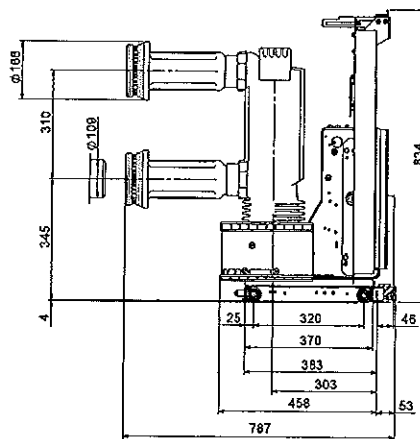
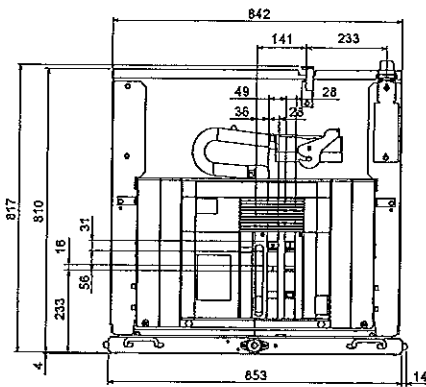

ВЯРНО С ОРИГИНАЛА



Withdrawable circuit-breakers for PowerCube modules

VD4/W	
TN	1VCD000152
Ur	12 kV
	17.5 kV
Ir	3150 A (*)
	20 kA
Isc	25 kA
	31.5 kA
	40 kA

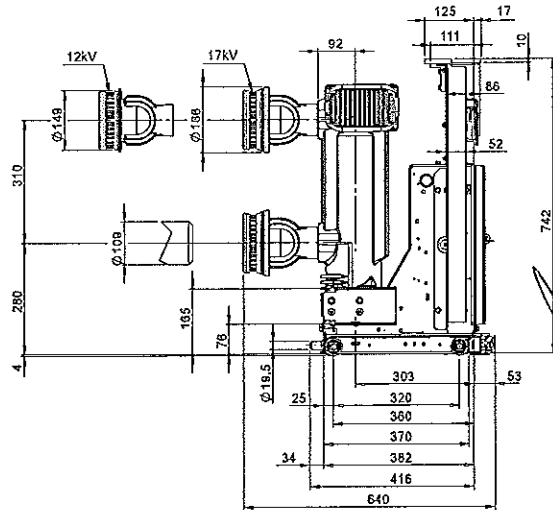
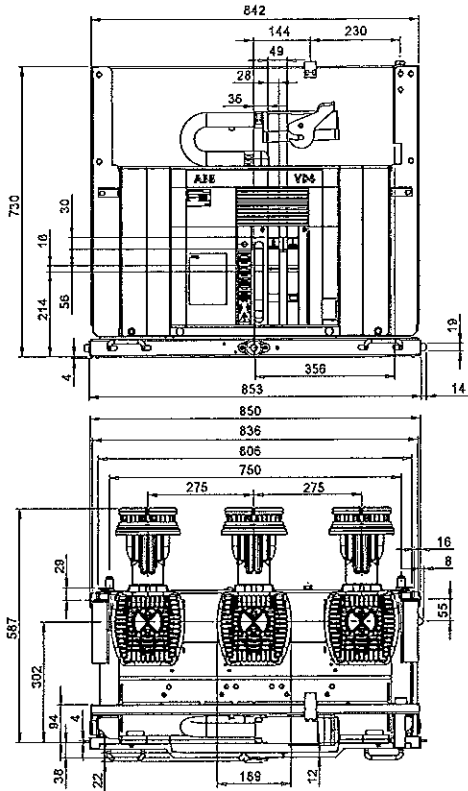

(\*) 4000 A with forced ventilation.

ВЯРНО С ОРИГИНАЛА



Withdrawable circuit-breakers for ZS8.4 switchgear

VD4/Z8	
TN	1VCD000092
Ur	12 kV
Ir	630 A
Isc	20 kA
	25 kA

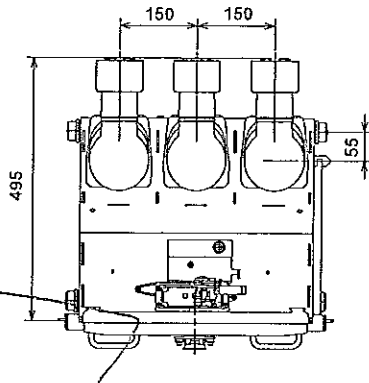
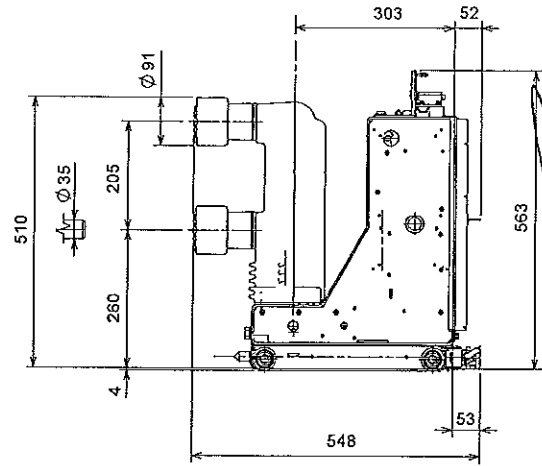
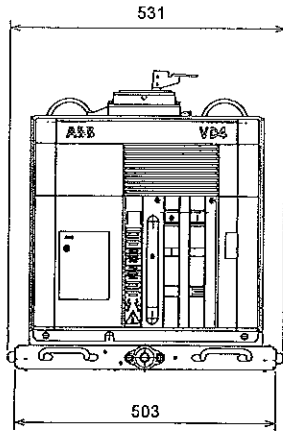

Withdrawable circuit-breakers for ZS8.4 switchgear

VD4/ZT8	
TN	1VCD000093
Ur	12 kV
Ir	630 A
Isc	20 kA
	25 kA

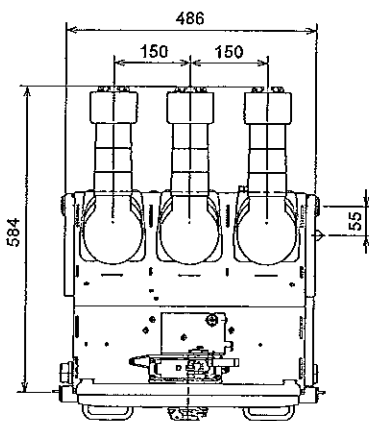
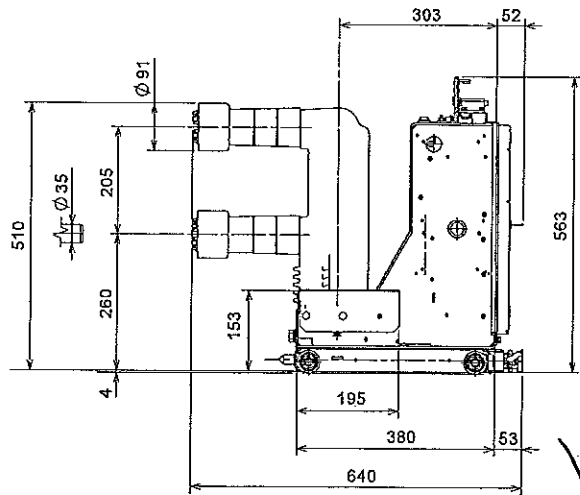
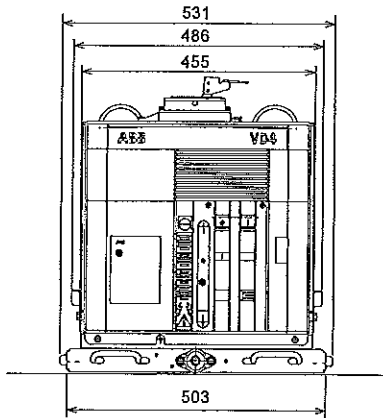

ВЯРНО С ОРИГИНАЛА



Withdrawable circuit-breakers for ZS8.4 switchgear

VD4/ZS8		
TN	1VCD000091	
Ur	12	kV
Ir	630	A
Isc	20	kA
	25	kA

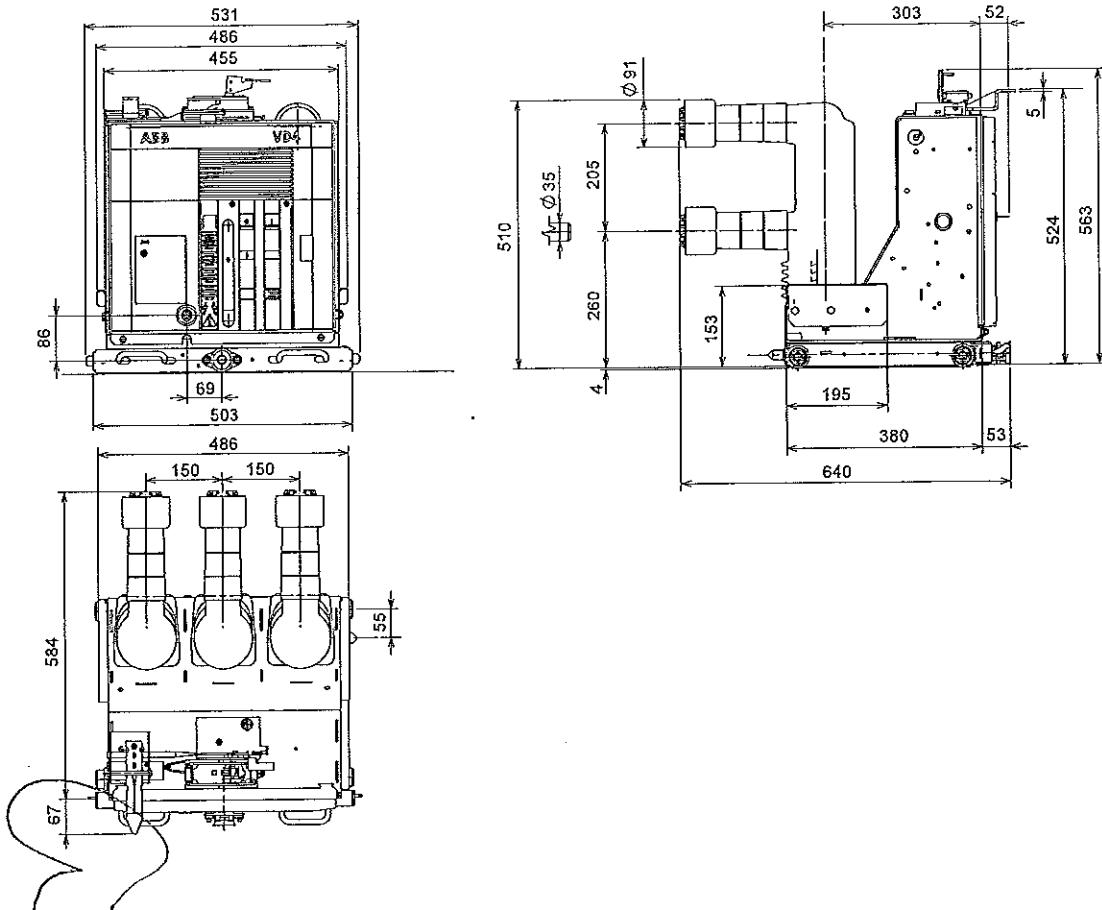

Withdrawable circuit-breakers for ZS8.4 switchgear

VD4/ZS8		
TN	1VCD000133	
Ur	12	kV
Ir	1250	A
Isc	20	kA
	25	kA

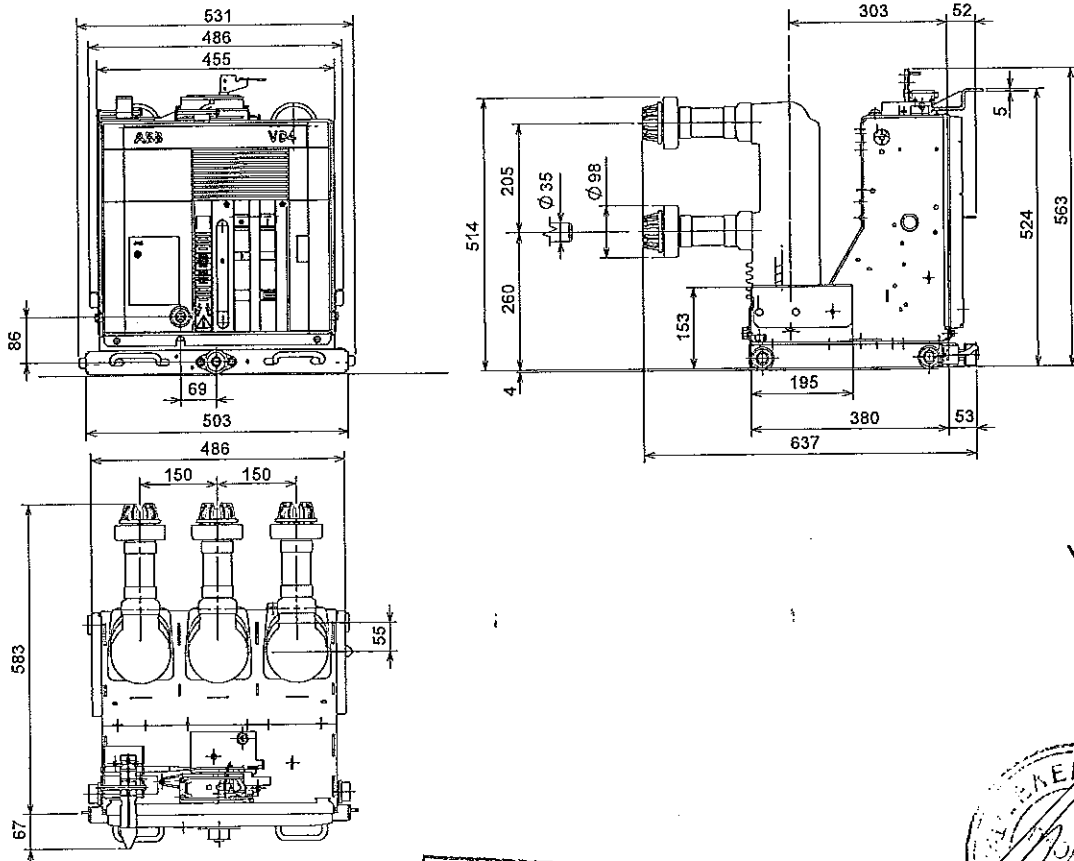

ВЯРНО С ОПРИМНАЛА



Withdrawable circuit-breakers for ZS8.4 switchgear

VD4/Z8	
TN	1VCD000137
Ur	12 kV
	17.5 kV
Ir	630 A
	1250 A
Isc	20 kA
	25 kA

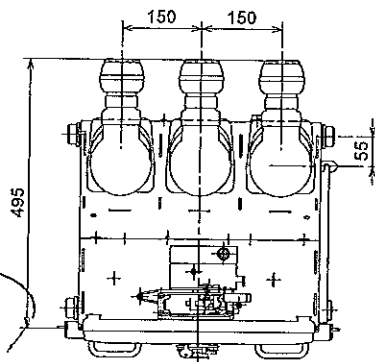
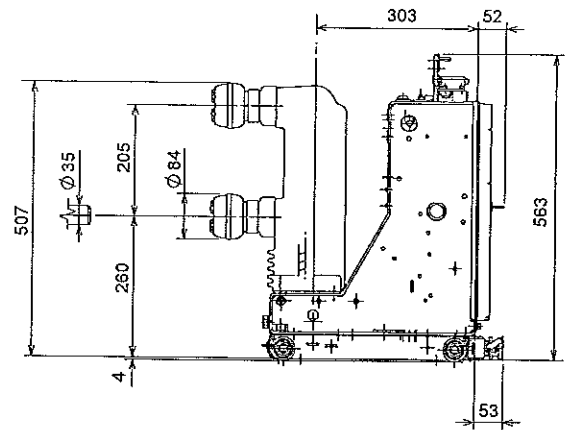
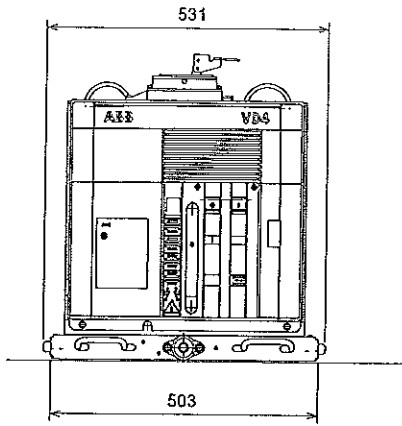

Withdrawable circuit-breakers for ZS8.4 switchgear

VD4/ZT8	
TN	1VCD000134
Ur	12 kV
	17.5 kV
Ir	630 A
	1250 A
Isc	20 kA
	25 kA

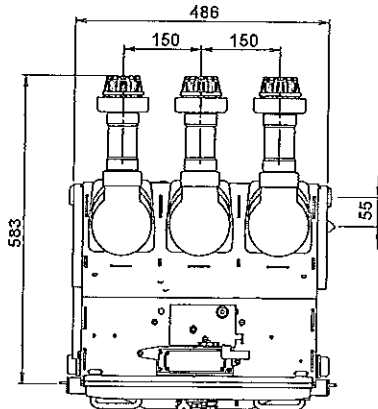
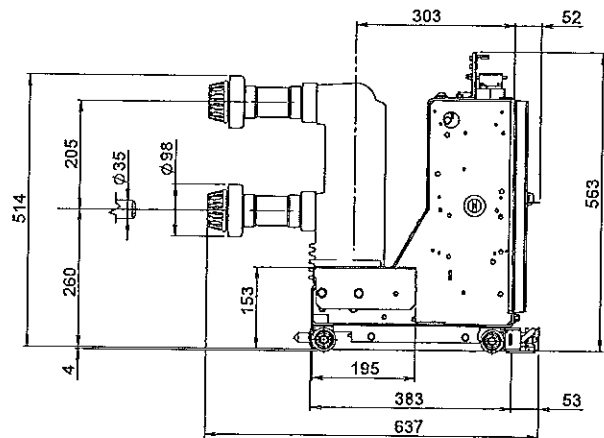
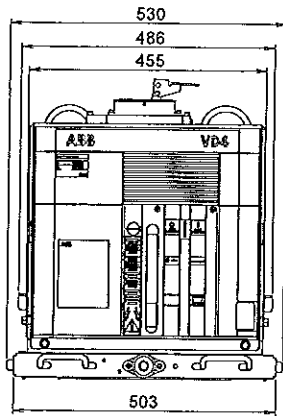

**ВЯРНО С ОРИГИНАЛА**



Withdrawable circuit-breakers for ZS8.4 switchgear

VD4/ZS8	
TN	1VCD000088
Ur	24 kV
Ir	630 A
Isc	16 kA
	20 kA
	25 kA

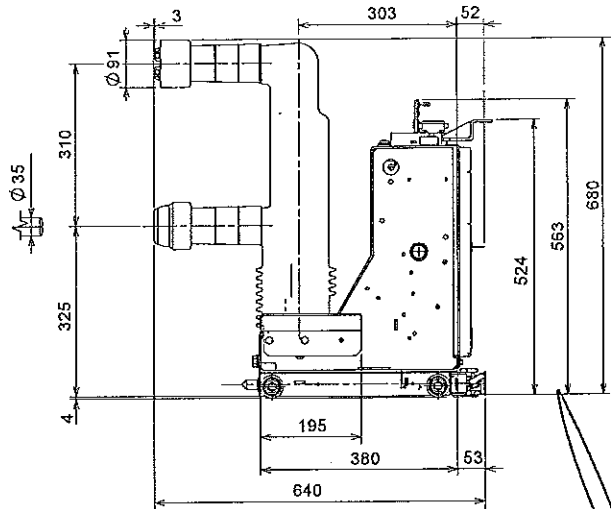
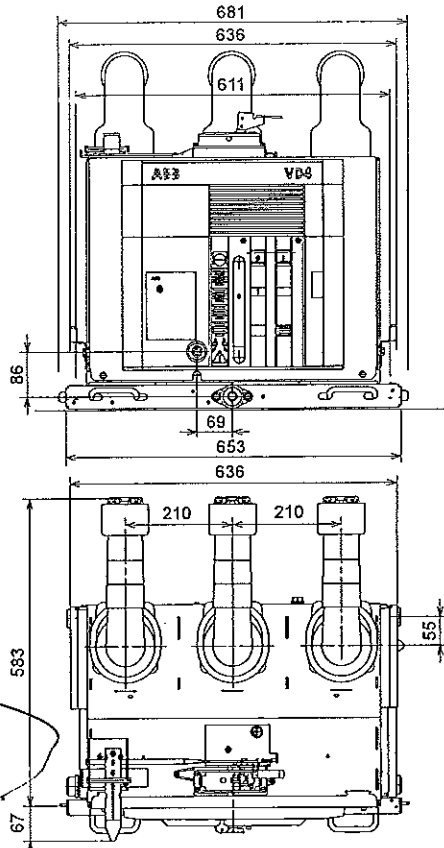

Withdrawable circuit-breakers for ZS8.4 switchgear

VD4/Z8	
TN	1VCD000089
Ur	24 kV
Ir	630 A
Isc	16 kA
	20 kA
	25 kA

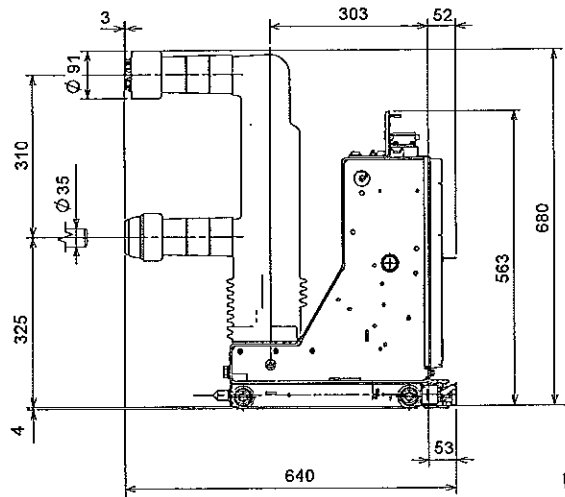
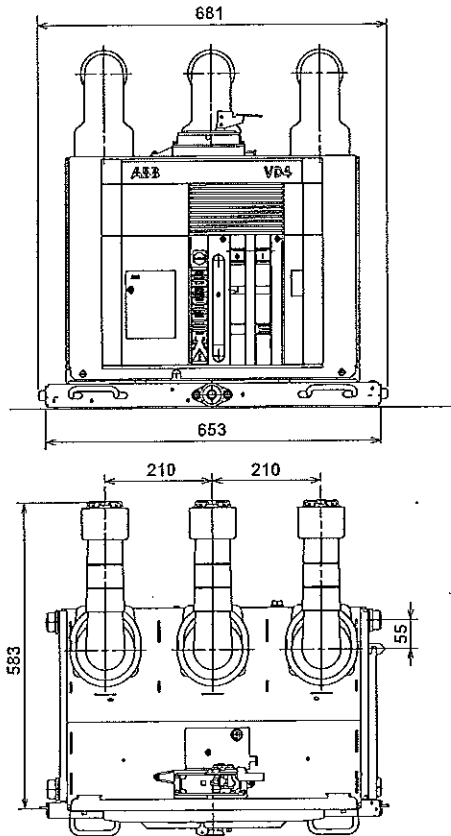

ВЕРНО С ОРИГИНАЛА



Withdrawable circuit-breakers for ZS8.4 switchgear

VD4/Z8		
TN	1VCD000138	
Ur	24	kV
Ir	1250	A
Isc	16	kA
	20	kA
	25	kA

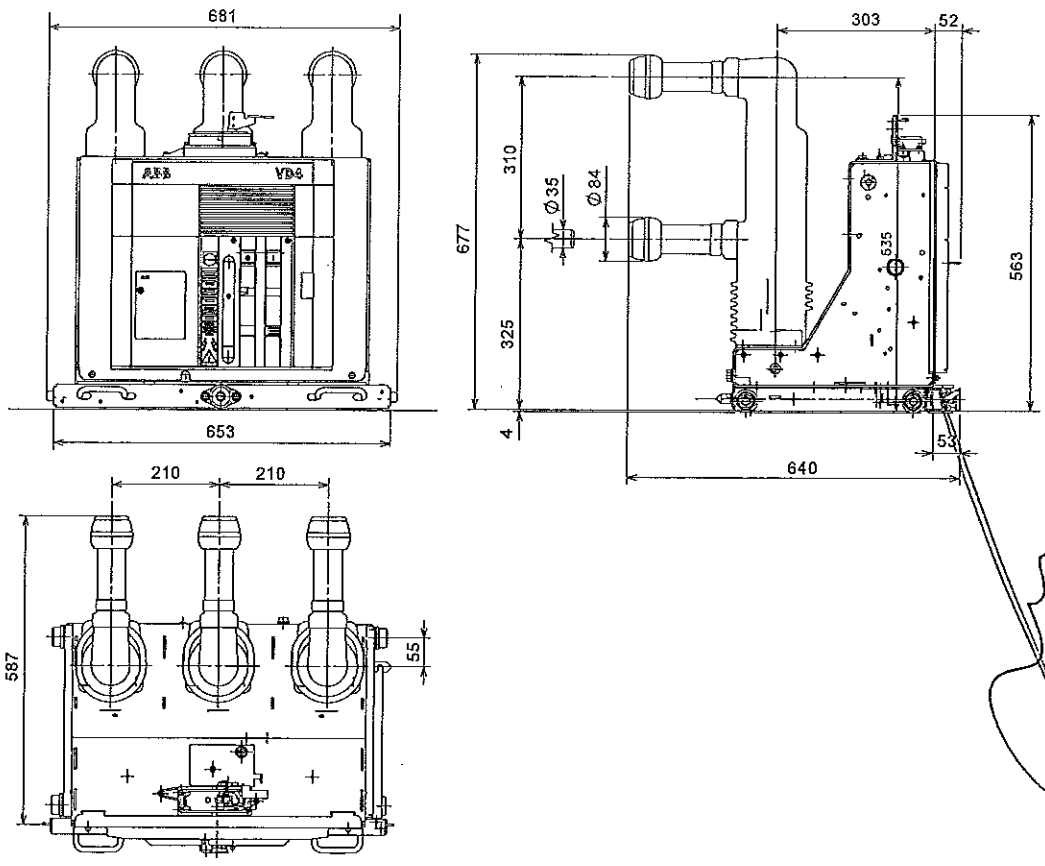

Withdrawable circuit-breakers for ZS8.4 switchgear

VD4/ZT8		
TN	1VCD000090	
Ur	24	kV
Ir	630	A
Isc	16	kA
	20	kA
	25	kA

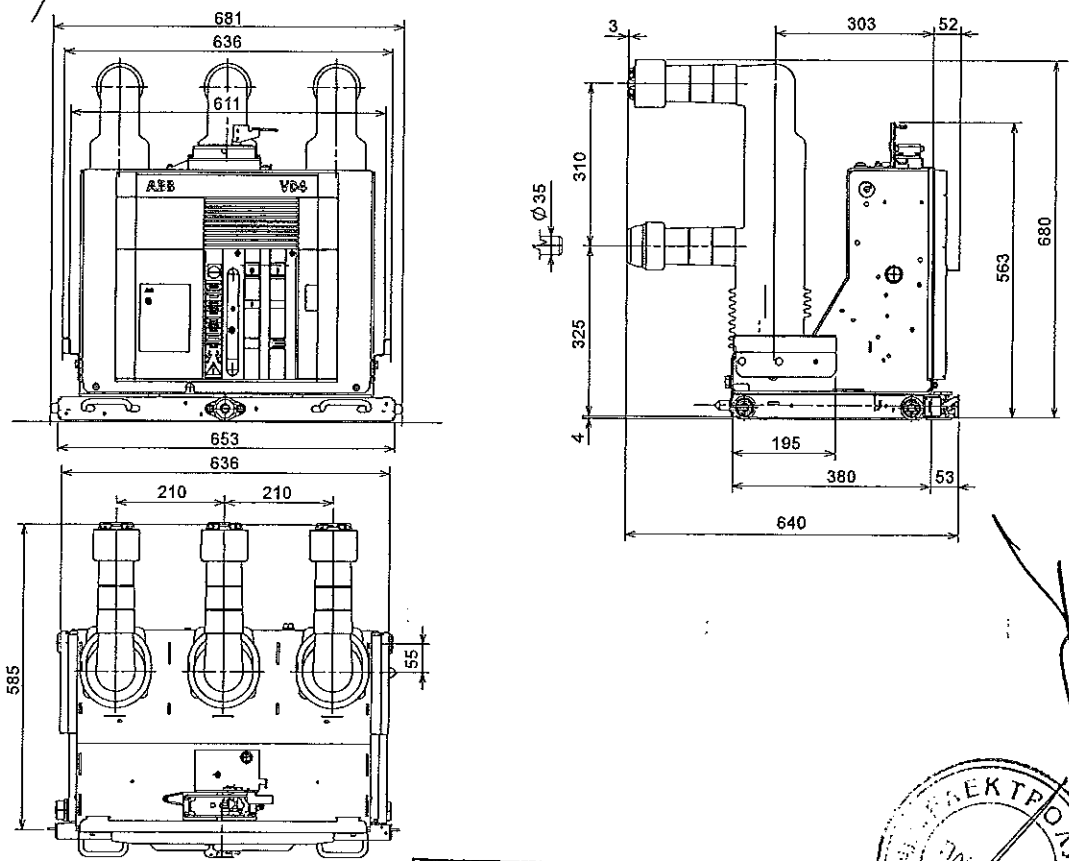

ВЯРНО С ОРИГИНАЛА





Withdrawable circuit-breakers for ZS8.4 switchgear

VD4/ZT8	
TN	1VCD000136
Ur	24 kV
Ir	1250 A
	16 kA
Isc	20 kA
	25 kA

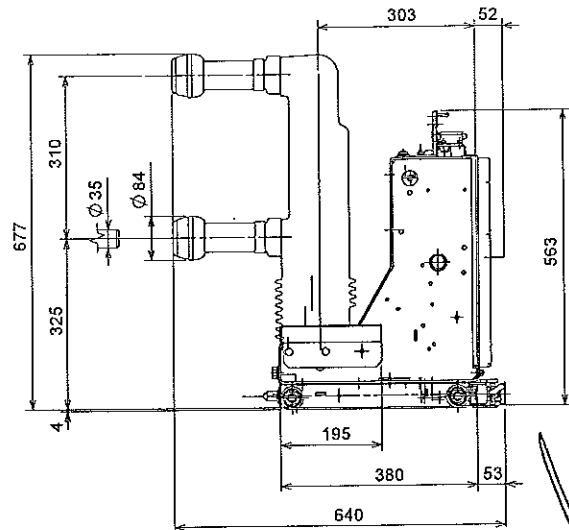
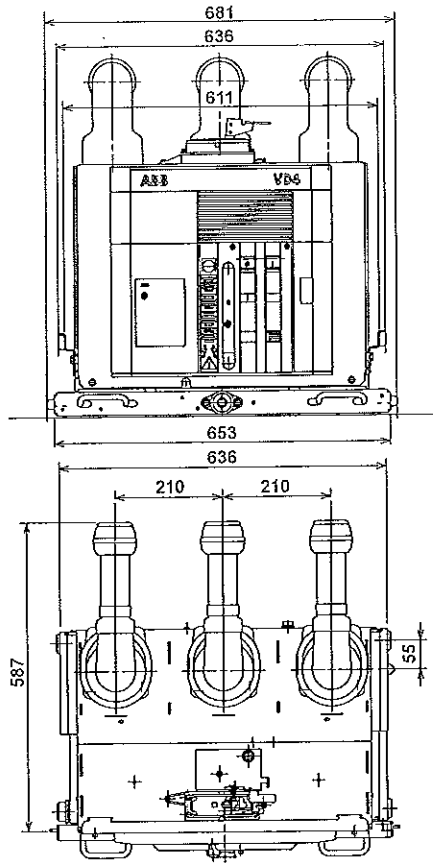

Withdrawable circuit-breakers for ZS8.4 switchgear

VD4/ZS8	
TN	1VCD000135
Ur	24 kV
Ir	1250 A
	16 kA
Isc	20 kA
	25 kA

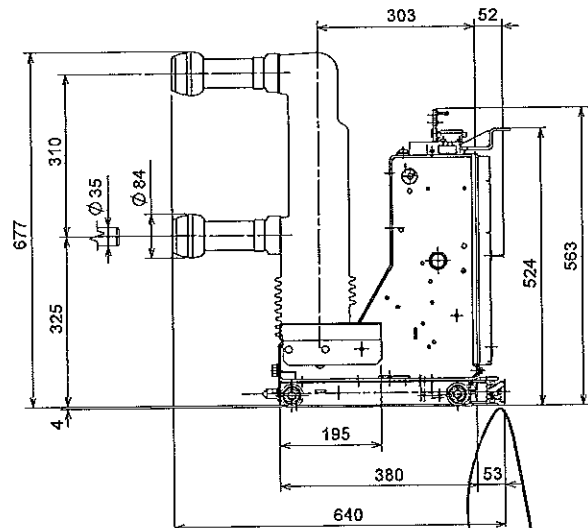
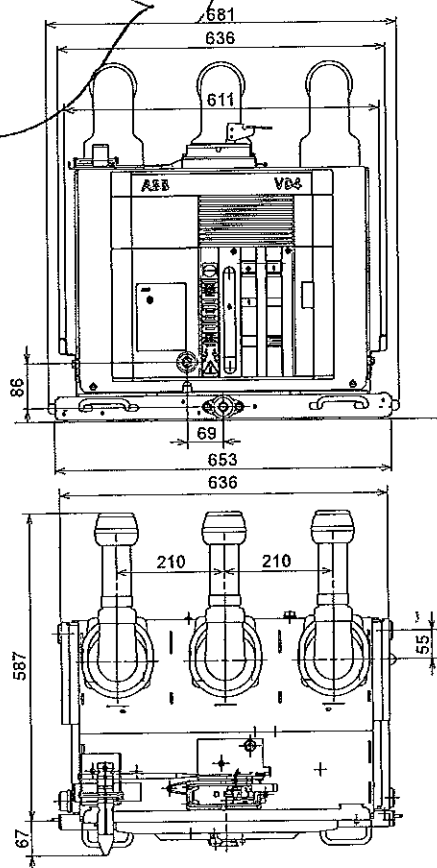

ВЕРНО С ОРИГИНАЛА



Withdrawable circuit-breakers for UniSwitch / UniMix switchgears

VD4/US	
TN	1VCD000047
Ur	24 kV
Ir	630 A
	1250 A
Isc	16 kA
	20 kA
	25 kA

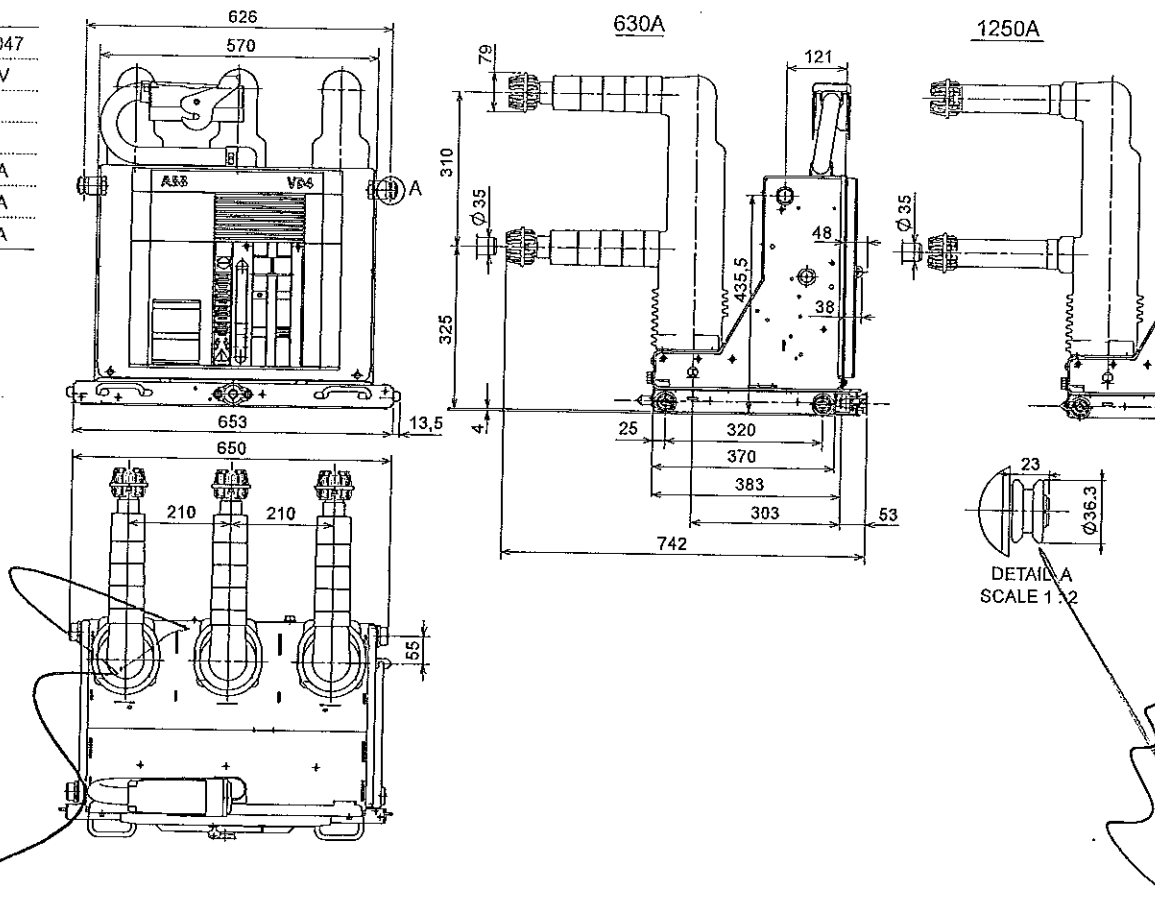

Withdrawable circuit-breakers for UniSec switchgears

VD4/SEC	
TN	1VCD000190
Ur	24 kV
Ir	630 A
	1250 A
Isc	16 kA
	20 kA
	25 kA

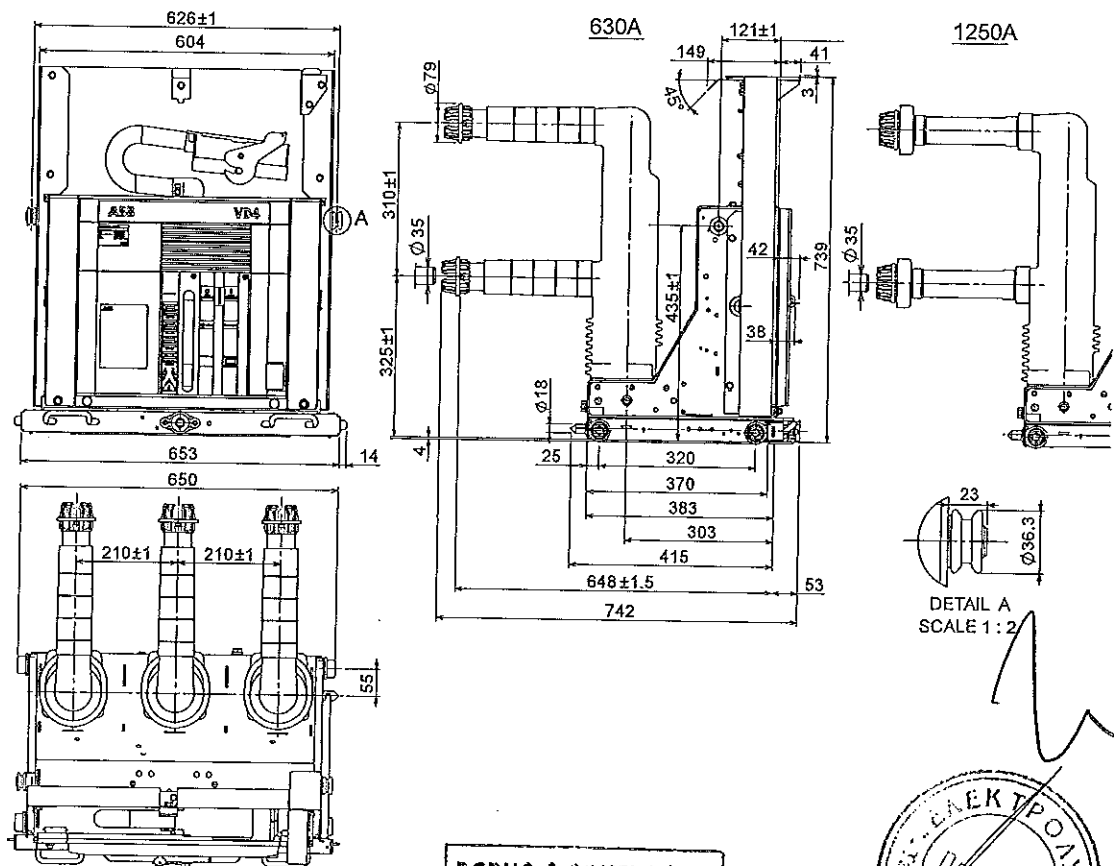

ВЕРНО С ОРИГИНАЛА

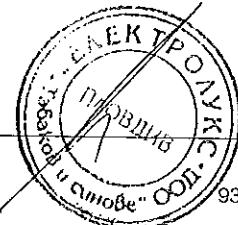

Withdrawable circuit-breakers for UniGear ZS2 switchgear and PowerCube modules (36 kV)

VD4		
TN	1VYN300901-KG	
Ur	36	kV
	1250	A
I <sub>r</sub>	1600	A
	2000	A
I <sub>sc</sub>	31.5	KA

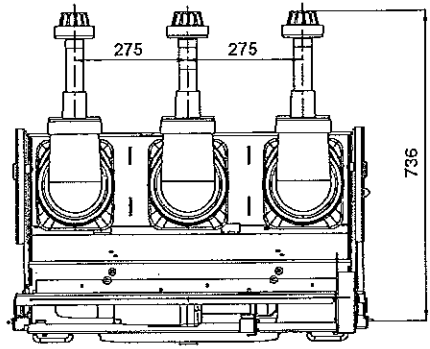
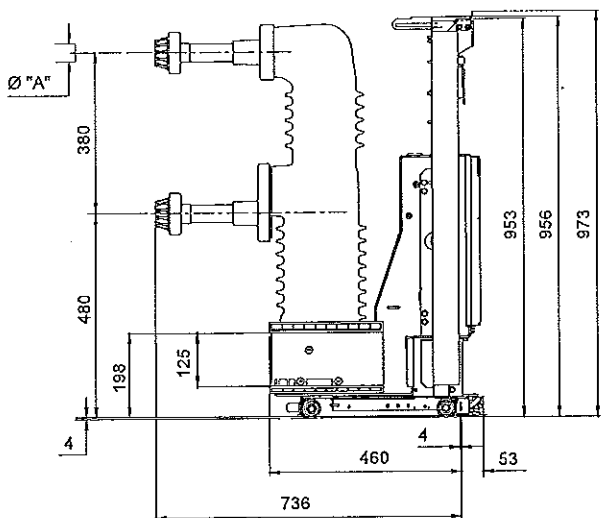
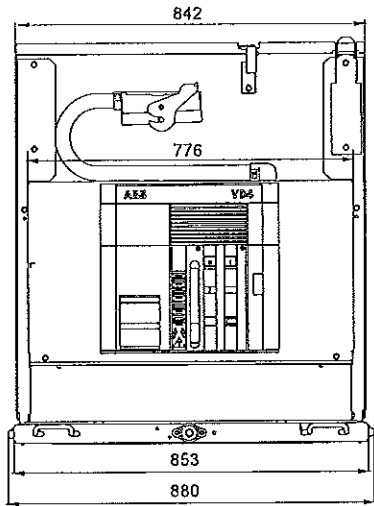

Breaker type	Ø A mm
VD4 36.12.32	35
VD4 36.16.32 - VD4 36.20.32	79

ВЕРНО С ОРИГИНАЛА



# 14. Product quality and environmental protection

The apparatus are produced in compliance with the requirements of international standards for the quality management system and environmental management system. In these fields, the excellent level is proved by quality certificates according to ISO 9001 and by the EMS according to ISO 14 001.

## End of life of product

The ABB company is committed to complying with the relevant legal and other requirements for environment protection according to the ISO 14 001 standard.

The duty of company is to facilitate subsequent recycling or disposal at the end of product life. During disposal of the product, it is always necessary to act in accordance with local legal requirements in force.

## Methods of disposal

Disposal can either be carried out thermally in an incineration plant or by storing on a waste site.

RAW MATERIAL	RECOMMENDED METHOD OF DISPOSAL
Metal material (Fe, Cu, Al, Ag, Zn, W, others)	Separation and recycling
Thermoplasts	Recycling or disposal
Epoxy resin	Separation of metal material and the disposal of rest
Rubber	Disposal
Oil as dielectric (transformer oil)	Draining from equipment and further recycling or disposal
Packing material - wood	Recycling or disposal
Packing material - foil	Recycling or disposal

ВЕРНО С ОРИГИНАЛА



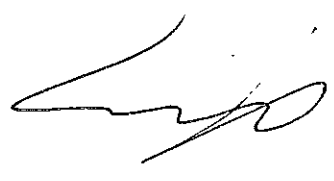

For more information please contact:

**ABB S.p.A.**  
**Power Products Division**  
Unità Operativa Sace-MV  
Via Friuli, 4  
I-24044 Dalmine  
Tel.: +39 035 6952 111  
Fax: +39 035 6952 874  
E-mail: info.mv@it.abb.com

**ABB AG**  
**Calor Emag Medium Voltage Products**  
Oberhausener Strasse 33  
D-40472 Ratingen  
Phone: +49(0)2102/12-1230, Fax: +49(0)2102/12-1916  
E-mail: powertech@de.abb.com  
[www.abb.com](http://www.abb.com)

The data and illustrations are not binding. We reserve the right to make changes without notice in the course of technical development of the product.

© Copyright 2014 ABB. All rights reserved.

647654/011 - Rev. Y, en - Instruction Manual - 2014.03 (VD4 up to 36 kV; up to 50 kA) (ps)(b)



**ВАРНО С ОРИГИНАЛА**



Power and productivity  
for a better world™ **ABB**



Приложение 1.2 - типови\_изпитания



ВЯРНО С ОРИГИНАЛА



**ABB Trasmissione & Distribuzione S.p.A.**  
**Unità operativa Sace T.M.S.**

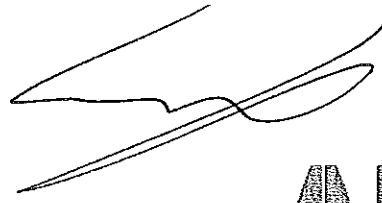

Via Friuli 4  
 I 24044 - Dalmine (BG)  
 Italy

Tel.: 0039.035.395111  
 Fax: 0039.035.395874  
 E-mail: [sacetms.tipm@it.abb.com](mailto:sacetms.tipm@it.abb.com)  
 Internet: [www.abb.com](http://www.abb.com)

**TYPE TEST DOCUMENTATION No. 100081\_C Page 1/1**

Apparatus: Metal-clad switchgear type ZS1 rel 1.2 with vacuum circuit-breaker  
 type VD4/P 12.12.31 p=210

Identification: 1VCP0000138-Rev.-,en-Technical catalogue-2003-04

Performances:

Rated voltage :	12	kV
Rated lightning impulse withstand voltage :	75	kV
Rated power-frequency withstand voltage :	28	kV
Rated frequency :	50-60	Hz
Rated normal current (busbar) :	1250	A
Rated normal current (tee-off) :	1250	A
Rated peak withstand current :	80	kA
Rated short-time withstand current :	31.5	kA
Rated duration of short circuit :	3	s

Test reports verifying rating assigned by the manufacturer:

Performances	Test according to	Test reports	
		No.	Issued by
Dielectric test	IEC 60298 Subclause 6.1	0003 Ra	PEHLA High-power Laboratories
Temperature-rise test	IEC 60298 Subclause 6.3/6.4	0009 Ra	PEHLA High-power Laboratories
Short-time and peak withstand current test	IEC 60298 Subclause 6.5	HZ 144 F08	Calor Emag Laboratories
Mechanical operation and interlock test	IEC 60298 Subclause 6.102	MZ ZS1 A03	Calor Emag Laboratories
Internal arc test	IEC 60298 Annex AA	HZ 146 L02	Calor Emag Laboratories
Mechanical operation test	IEC 62271-100 subclause 6.101.2	0316 Ra	PEHLA High-power Laboratories
Making and breaking capacity test	IEC 62271-100 subclause 6.106	0231 Ra	PEHLA High-power Laboratories

ABB T&D Unità operativa SACE T.M.S. Laboratories Dalmine are accredited according UNI CEI EN ISO/IEC 17025 by SINAL under Reg. No. 0253  
 ABB Calor Emag Laboratories Ratingen are accredited according UNI CEI EN ISO/IEC 17025 by DATech under Reg. No. DAT-P-032/93  
 PEHLA High-power Laboratories are accredited according UNI CEI EN ISO/IEC 17025 by DATech under Reg. No. DAT-P-032/93

Date of issue:  
 03/09/23

Development Dept.  
 G.M. Cravanzola

*Handwritten signature of G.M. Cravanzola*

ABB T&D Unità operativa Sace T.M.S. is accredited by DET NORSKE VERITAS QUALITY CERTIFICATE Quacer Certificate  
 No. CERT-07978-2001-AQ-MIL-SINCERT/B according to ISO 9001.

**ВАРНО С ОПРИГНАЛА!**

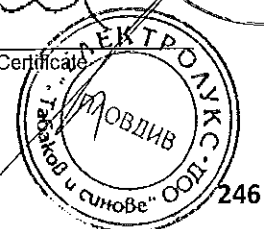

*Handwritten mark or signature at the bottom left.*

**АББ Трансмисионе & Дистрибузионе С.п.А.**  
**Унита Оператива Саче Т.М.С.**



Виа Фриули 4  
 I 24044 -- Далмине (BG)  
 Италия

тел.: 0039.035.395111  
 факс: 0039.035.395874  
 E-mail: [sacetms.tipm@it.abb.com](mailto:sacetms.tipm@it.abb.com)  
 интернет: [://www.abb.com](http://www.abb.com)

**ПРОТОКОЛ ЗА ТИПОВИ ИЗПИТАНИЯ No. 100081\_С СТРАНЦИ 1/1**

Apparatus: КРУ тип ZS1 изд. 1.2 с вакуумнен прекъсвач тип VD4/P  
 12.12.31 p=210

Идентификация: 1VCP0000138-Rev.-,en-Технически каталог-2003-04

Параметри:

Номинално напрежение:	12	kV
Ном. Издържано импулсно напрежение:	75	kV
Ном. Издържано напрежение с 50Hz:	28	kV
Номинална честота:	50-60	Hz
Номинален ток на шината:	1250	A
Номинален ток на ошиновката:	1250	A
Ном. Издържан ток, пикова стойност:	80	kA
Ном. Издържан кратковременен ток на к.с.:	31.5	kA
Ном. Продължителност на к.с.:	3	s

Test reports verifying rating assigned by the manufacturer:

Изпитания	Тест съгласно стандарт	Тестов протокол	
		No.	Издаден от
Диелектричени изпитания	IEC 60298 Subclause 6.1	0003 Ra	ПЕХЛА Високо-мощностни лаборатории
Тест с повишаване на температурата	IEC 60298 Subclause 6.3/6.4	0009 Ra	ПЕХЛА Високо-мощностни лаборатории
Тест за кратковременен т.к.с. и пиков т.к.с.	IEC 60298 Subclause 6.5	HZ 144 F08	АББ Калор Емаг Лаборатории
Механична работа и тест за блокировки	IEC 60298 Subclause 6.102	MZ ZS1 A03	АББ Калор Емаг Лаборатории
Тест за вътрешна дъга	IEC 60298 Annex AA	HZ 146 L02	АББ Калор Емаг Лаборатории
Тест за механична работа	IEC 62271-100 subclause 6.101.2	0316 Ra	ПЕХЛА Високо-мощностни лаборатории
Тест за способност за изкл. на т.к.с. и вкл. върху т.к.с.	IEC 62271-100 subclause 6.106	0231 Ra	ПЕХЛА Високо-мощностни лаборатории

Лабораторията на АББ ТИД Унита Оператива САЧЕ Т.М.С. в гр. Далмине е акредитирана съгласно UNI CEI EN ISO/IEC 17025 от SINAL с регистрационен номер Reg. No. 0253  
 Лабораторията на АББ Калор Емаг в гр. Ратинген, Германия е акредитирана съгласно UNI CEI EN ISO/IEC 17025 от DATech под регистрационен номер No. DAT-P-032/93  
 Високо-мощностните лаборатории ПЕХЛА са акредитирани съгласно UNI CEI EN ISO/IEC 17025 от DATech с регистрационен номер No. DAT-P-032/93 и сертификат Д-ПЛ-12072-06-01

Дата на издаване:  
 03/09/23

Отдел за Развойна дейност

Г.М. Граванзола

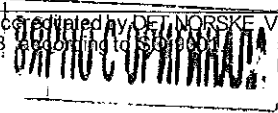
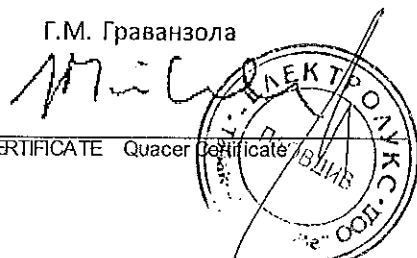



# PEHLA

GESELLSCHAFT FÜR ELEKTRISCHE HOCHLEISTUNGSPRÜFUNGEN  
Member of the Short-Circuit-Testing Liaison (STL)

## Test Report

Report No.: 0316 Ra

Copy No.: 1

Contents: 24 Sheets

Equipment under test: Vacuum circuit-breaker type VD4 17.12.32

**Manufacturer:**

Circuit-breaker: ABB T&D S.p.A. - Unità operativa Sace TMS, Via Friuli, 4 - 24044 Dalmine (BG), Italy

Pole parts inclusive

vacuum interrupter: ABB Calor Emag Mittelspannung GmbH, 40472 Ratingen, Germany

Client: ABB T&D S.p.A. - Unità operativa Sace TMS, Via Friuli, 4 - 24044 Dalmine (BG), Italy

Testing station: PEHLA - Testing Laboratory Ratingen

Date of test: 28<sup>th</sup> April 2003 - 21<sup>st</sup> May 2003

**Applied test specifications:**

IEC 62271-100, 1<sup>st</sup> Ed, 2001-05, clause 6.101.1 and 6.101.2

IEC 60694, Ed.2.2, 2002-01

**Tests performed:**

In accordance with the requirements of class M2, 10 000 mechanical operating cycles without voltage on or current in the main circuit were carried out with the vacuum circuit-breaker of type VD4 17.12.32 to demonstrate the mechanical reliability.

**Test results:**

No changes impairing the function of the circuit-breaker were noted after the endurance test. The vacuum circuit-breaker type VD4 17.12.32 passed the mechanical type test successfully.

GESELLSCHAFT FÜR ELEKTRISCHE  
HOCHLEISTUNGSPRÜFUNGEN

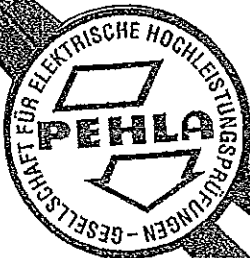

Technical Committee

Mannheim, 25<sup>th</sup> July 2003

The test results relate only to the items tested.

Without a written permission of PEHLA it is not allowed to make reproduction in extracts of this document. Copying the cover sheet accompanied by sheet 2 and the sheets mentioned here is an exception.

03PE0001

ВЕРНО С ОРИГИНАЛОМ

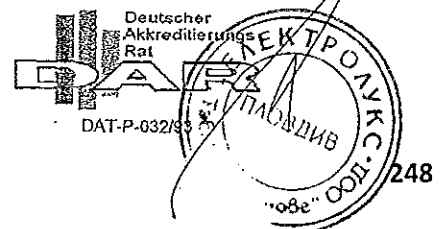

**Accreditation**

The PEHLA-Testing Laboratory Ratingen has been approved by the DATech (German accreditation body for technology) according to DIN EN ISO/IEC 17025 for tests in the field of high-voltage switchgear and controlgear and power engineering equipment (Registration-No. DAT-P-032/93).

Under reference to DIN EN ISO/IEC 17025 PEHLA states the following:

- The accreditation of the PEHLA-Testing Laboratory or any of its test reports by themselves in no way constitute or imply product approval by DATech or any other body.
- If someone refers to a test in an accredited PEHLA-Testing Laboratory this reference shall include the accreditation body, i.e. DATech, the relevant scope of the accreditation and the appropriate registration number.

**STL-Member**

PEHLA is foundation-member of the Short-Circuit Testing Liaison (STL) which has been founded in March 1969. STL is a forum for the international co-operation of the testing organisations with the further full members ASTA (GB), CESI (I), ESEF (F), KEMA (NL), SATS (N, S, AIR) and STLNA (USA). In the Framework of EC, STL has been recognised in 1992 by EOTC as agreement group.

**PEHLA-Documents****A Certificate**

is issued for type tests which have successfully been carried out in full compliance with the relevant specifications or standards and STL Guides valid at the time of the test.

For these tests the equipment under test must be clearly identified by technical description, drawings and additional specifications.

**A Test Document**

is issued for parts of type tests which have successfully been carried out in full compliance with the relevant specifications or standards and STL Guides valid at the time of test.

For these tests the equipment under test must be clearly identified by technical description, drawings and additional specifications.

**A Test Report**

is issued for all other tests which have been carried out according to specifications, standards or "PEHLA-Richtlinien" (PEHLA Guides) and/or clients instructions.

Similarly, this test report contains all test results, details of the conditions under which the tests were carried out, also details relating to the behaviour of the equipment during test, and its condition after the tests.

**Addresses:**

Office: PEHLA-Geschäftsstelle  
Hallenweg 40  
68219 Mannheim; Germany

Testing Station: PEHLA-Testing Laboratory Ratingen  
Oberhausener Str. 33  
40472 Ratingen; Germany

Manufacturer: ABB T&D S.p.A - Unità Operativa Sace TMS  
Via Friuli, 4  
24044 Dalmine (BG), Italy

ABB Calor Emag Mittelspannung GmbH  
Oberhausener Str. 33  
40472 Ratingen, Germany

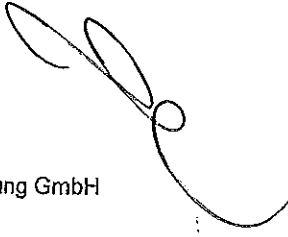

Client: ABB T&D S.p.A - Unità Operativa Sace TMS  
Via Friuli, 4  
24044 Dalmine (BG), Italy

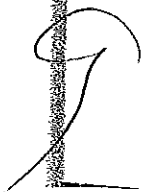
  
**ВЕРНО С ОРИГИНАЛОМ**



## List of Test Participants

### Representatives of the Test Committee:

Mr. G. Heit  
Mr. K.-H. Koch  
Mr. M. Schöttler  
Mr. U. Köster

PEHLA-Testing Laboratory Mannheim  
PEHLA-Testing Laboratory Mannheim  
PEHLA-Testing Laboratory Ratingen  
PEHLA-Testing Laboratory Ratingen

### Test Operator:

Mr. M. Schöttler  
Mr. H.-W. Ott  
Mr. J. Mendorf  
Mr. A. Piglas

PEHLA-Testing Laboratory Ratingen  
PEHLA-Testing Laboratory Ratingen  
PEHLA-Testing Laboratory Ratingen  
PEHLA-Testing Laboratory Ratingen

### Representatives of the Client:

Mr. S. Magoni  
Mr. L. Cavenati

ABB T&D S.p.A. - Unità operativa Sace TMS, Italy  
ABB T&D S.p.A. - Unità operativa Sace TMS, Italy

  
ВЯРНО С ОПРИСНИДА

**Technical Data of Test Object**

**Switching Device – Circuit-Breaker**

Ratings assigned by the manufacturer

**Test Object:** Vacuum circuit-breaker  
**Type:** VD4 17.12.32  
**Manufacturer:**  
**Circuit-breaker:** ABB T&D S.p.A. - Unità operativa Sace TMS, Via Friuli, 4 – 24044 Dalmine (BG), Italy  
**Pole parts including vacuum interrupters:** ABB Calor Emag Mittelspannung GmbH, 40472 Ratingen, Germany  
**Serial-No.:** AD00011927 **Year of manufacture:** 2003  
**Drawing No.:** TN. 7405 (circuit-breaker)  
**Vacuum interrupter:** Type VG4S, L1: No. 489814, L2: No. 488577, L3: No. 485245  
**Drawing No.:** GCE7003979R0131 (pole part)

Rated voltage	17.5 kV
Rated lightning impulse withstand voltage	95 kV
Rated switching impulse withstand voltage	- kV
Rated power frequency withstand voltage	38 kV
Rated frequency	50 Hz
Rated normal current	1250 A
Rated peak withstand current	80 kA
Rated short-time withstand current	31.5 kA
Rated duration of short-circuit	3 s
Rated short-circuit breaking current at 17.5 kV	31.5 kA
D.C. component	30 %
Rated short-circuit making current at 17.5 kV	80 kA
Rated transient recovery voltage:	
Peak value	30 kV
Rate of rise	0.42 kV/μs
First-pole-to-clear-factor	1.5
Rated operating sequence	O-0.3s-CO-3min-CO
Arc extinguishing medium	vacuum
Number of poles	3
Number of units per pole	1
Rated opening time	≥ 45 ms
Rated closing time	approx. 60 ms
Rated voltage of trip coil	220 V-DC
Rated voltage of closing coil	220 V-DC
Rated supply voltage	220 V-DC
Rated frequency of supply voltage	- Hz

**Essential characteristics and installed devices:**

Motor Drive Type 701 921/804 (EL1)

Date of receipt of test object: 23<sup>rd</sup> April 2003

**ВЯРНО С ОРИГИНАЛА**



### List of Drawings

The manufacturer has guaranteed, that the equipment submitted for test has been manufactured in full accordance with the following drawings. PEHLA has verified that these drawings adequately represent the equipment tested. These drawings have been stamped and signed by PEHLA representatives and are kept

- with the test documents at the test laboratory.
- at the client.

The drawings contained in this document are identical with the checked, stamped and signed drawings.

Drawing-No.	Revision	Title	Additional remarks
TN. 7405	M5234	VACUUM CIRCUIT BREAKER TYPE VD4 12-17.5kV:630-1250A	Included in test report
510507	50538	OPERATING MECHANISM ASSEMBLY	Included in test report
GCE7003979R0131	00	pole complete VD4P 12kV 1250A 31,5kA	Included in test report
510564	50538	CLOSING SPRINGS ASSEMBLY	---
RA2129	L0488	COMPRESSION SPRING	---
GCE7005535R0101	03	Montagegruppe	---
<b>Parts list</b>			
510564		Ass. molle di ch. com. EL1	---
510507		Assieme comando EL1	---
GCE7003979R0131		Pol vst. 40,7 3150N H205 12/171231 VG4S	---

**ВЯРНО С ОРИГИНАЛА**











## Details on Performance of the Test

Prior to the endurance test, the following electrical and mechanical data were determined by measurements on the circuit-breaker and its auxiliary systems:

- a) closing time (5 times \*)
- b) opening time (5 times \*)
- c) time spread between units of one pole - not applicable
- d) time spread between poles (5 times \*)
- e) charging time of the motorized operating mechanism (5 times \*)
- f) consumption of the motorized operating mechanism (5 times \*)
- g) consumption of the tripping devices (5 times \*)
- h) duration of opening and closing command impulse
- i) tightness
- j) gas densities or pressures - not applicable
- k) resistance of the main circuit (5 times \*)
- l) time-travel chart (5 times \*)
- m) other important characteristics
  - contact travel
  - check of vacuum of interrupters
  - verification of the rated operating sequence (refer to clause 6.101.2.5 a))
  - ambient atmospheric conditions

\*) 5 times at rated, minimum and maximum supply voltage.

The subsequent endurance test comprising 10 000 mechanical operating cycles was structured as follows and carried out five times:

500 operating cycles with operating sequence C - 30 s - O - 30 s at the minimum supply voltage of closing and opening devices and motorized operating mechanism and the minimum pressure for operation

500 operating cycles with operating sequence C - 30 s - O - 30 s at the rated supply voltage of closing and opening devices and motorized operating mechanism and the rated pressure for operation

500 operating cycles with operating sequence C - 30 s - O - 30 s at the maximum supply voltage of closing and opening devices and motorized operating mechanism and at the maximum pressure for operation

250 operating cycles with operating sequence C - 30 s - O - 300 ms - CO - 90 s at the rated supply voltage of closing and opening devices and motorized operating mechanism and at the rated pressure for operation

For faster operation, the recharging motor was cooled by air pressure.

After each series of 2 000 operating sequences the operating characteristics: a), b), d), e), and l) as listed above have been recorded.

Following the endurance test, the measurements carried out before the mechanical endurance test were measured again for comparison. Check, whether the travel characteristics fell within the envelope curves, taken before the endurance test.

ВЕРНО С ОРИГИНАЛА

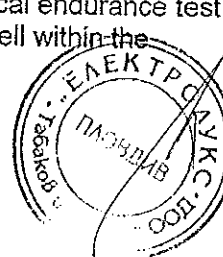

**Results of measurements before the mechanical endurance test**

Number of operations: counter: 99893

**a/b) Opening and closing time:**

Ua = 220 V DC

Operating time [ms]

- measured during the 5 x CO operations
- at the minimum supply voltage
  - at the rated supply voltage
  - at the maximum supply voltage

U [V]	t <sub>o</sub> (opening)			t <sub>c</sub> (closing)		
	0.7 x Ua	1.0 x Ua	1.1 x Ua	0.85 x Ua	1.0 x Ua	1.1 x Ua
	60.6	46.5	44.4	67.8	63.6	61.5
	61.5	46.8	44.4	67.8	63.6	61.2
t [ms]	61.8	46.5	44.4	67.8	63.3	61.2
	61.5	46.5	44.4	68.1	63.6	61.5
	61.2	46.5	44.4	67.8	63.6	61.2

**d) Time spread between the breaker poles:**

The time spread between the breaker poles on closing and on opening of the circuit-breaker was measured to < 2 ms.

**e/f) Charging time and power consumption of the motorized operating mechanism:**

Rated voltage: Ua = 220 V DC

Measured values:

- Measured during the 5 x CO operations
- at the minimum supply voltage
  - at the rated supply voltage
  - at the maximum supply voltage

motor voltage	charging time after O-C operation [s]					current consumption [A]					power consumption [W]				
U = 0.85 x Ua = 187 V DC	3.67	3.74	3.67	3.66	3.71	0.96	0.96	0.94	0.94	0.95	180	180	176	176	178
U = 1.0 x Ua = 220 V DC	2.89	2.96	2.94	2.95	2.97	0.96	0.95	0.94	0.95	0.96	211	209	207	209	211
U = 1.1 x Ua = 242 V DC	2.63	2.59	2.74	2.74	2.74	0.98	0.97	0.97	0.96	0.97	237	235	235	232	235

**ВЕРНО С ОРИГИНАЛОМ**



(

(

**g) Consumption of the tripping devices:**

- Measured during the 5 x CO operations
- at the minimum supply voltage
  - at the rated supply voltage
  - at the maximum supply voltage

Rated operating voltage $U_a$	Shunt-release ON -MC					Shunt-release OFF -MO1				
	220 V DC					220 V DC				
Current at minimum supply voltage [ A ]	0.68	0.68	0.68	0.68	0.68	0.50	0.52	0.52	0.52	0.52
Current at rated supply voltage [ A ]	0.84	0.84	0.84	0.84	0.84	0.68	0.64	0.64	0.64	0.68
Current at maximum supply voltage [ A ]	0.92	0.92	0.92	0.92	0.92	0.72	0.72	0.72	0.76	0.76

**h) Duration of closing and opening command impulse:**

- Measured during the 5 x CO operations
- at the minimum supply voltage
  - at the rated supply voltage
  - at the maximum supply voltage

Duration of command impulse at minimum supply voltage [ ms ]	Shunt-release ON -MC					Shunt-release OFF -MO1				
		72.0	71.7	70.2	72.3	72.0	65.1	67.2	67.5	65.7
Duration of command impulse at rated supply voltage [ ms ]	67.5	68.4	68.4	69.3	69.6	47.7	48.6	48.9	48.3	48.9
Duration of command impulse at maximum supply voltage [ ms ]	72.6	70.5	71.4	70.5	68.1	48.6	49.5	47.1	47.1	49.2

**k) Resistance of the main conductors:**

Measuring points:

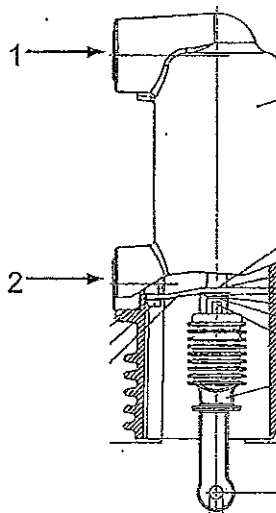

ВЕРНО С ОРИГИНАЛА



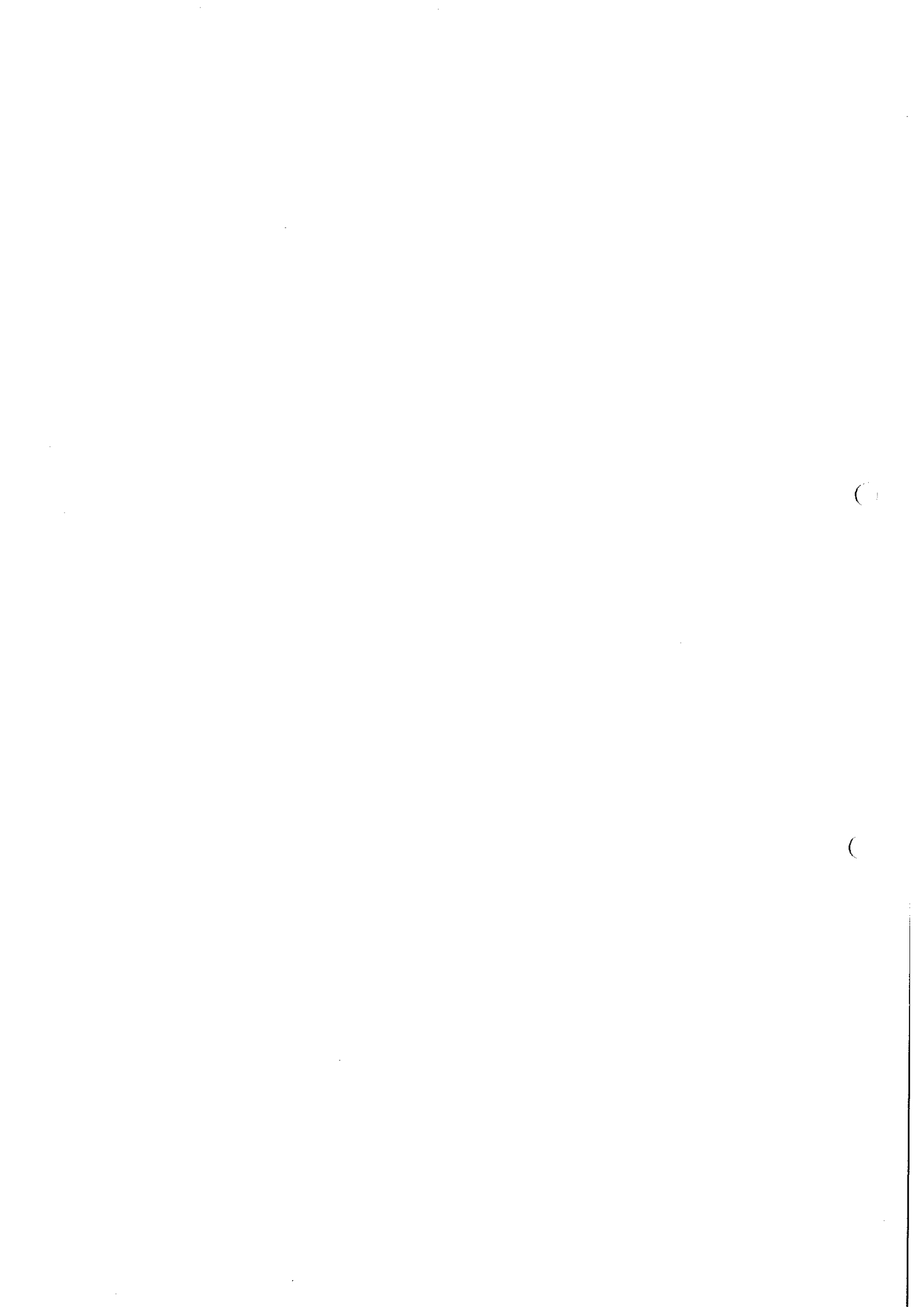

Contact resistance measured during the 5 x CO operations at the minimum supply voltage of the coils:

Measuring points	L1 μΩ	L2 μΩ	L3 μΩ
1 - 2	15.1	15.2	15.4

Contact resistance measured during the 5 x CO operations at the rated supply voltage of the coils:

Measuring points	L1 μΩ	L2 μΩ	L3 μΩ
1 - 2	15.1	15.2	15.4

Contact resistance measured during the 5 x CO operations at the maximum supply voltage of the coils:

Measuring points	L1 μΩ	L2 μΩ	L3 μΩ
1 - 2	15.1	15.2	15.3

l) Time-travel chart with opening and closing speed: See diagram 1.1 and 1.2

Speed in [m/s]; U<sub>a</sub> = 220 V DC  
at U = 1.0 x U<sub>a</sub>

	V <sub>o1</sub>	V <sub>o2</sub>	V <sub>c</sub>
L2	1.24	1.45	0.91

The deviations from the measured mechanical time travel charts are in the allowable limits of the reference mechanical travel characteristics.

- Vo1: opening speed considered 8.25 mm after the separation in the main contacts of phase L2.
- Vo2: opening speed considered between 1.65 and 8.25 mm after the separation in the main contacts of phase L2.
- Vc: closing speed considered 3.3 mm before the touching in the main contacts of phase L2.

m) Other important characteristics:

▪ Contact travel:

	L1	L2	L3
Total Travel [mm]	14.5	14.5	14.7
Cont.-travel [mm]	11.2	11.2	11.2
Contact-spring travel [mm]	3.3	3.3	3.5

- Check of vacuum of interrupters:  
80 kV DC ok
- Verification of the rated operating sequence:  
O-0.3s-CO-3min-CO at rated voltage ok
- Ambient atmospheric conditions:  
Date: 28<sup>th</sup> April 2003, ambient air temperature: approx. 23°C

ВЯРНО С ОРИГИНАЛА



(

(

\_\_\_\_\_





(

(

---

Diagram 1.2: Measurement of the operating speed before the mechanical endurance test

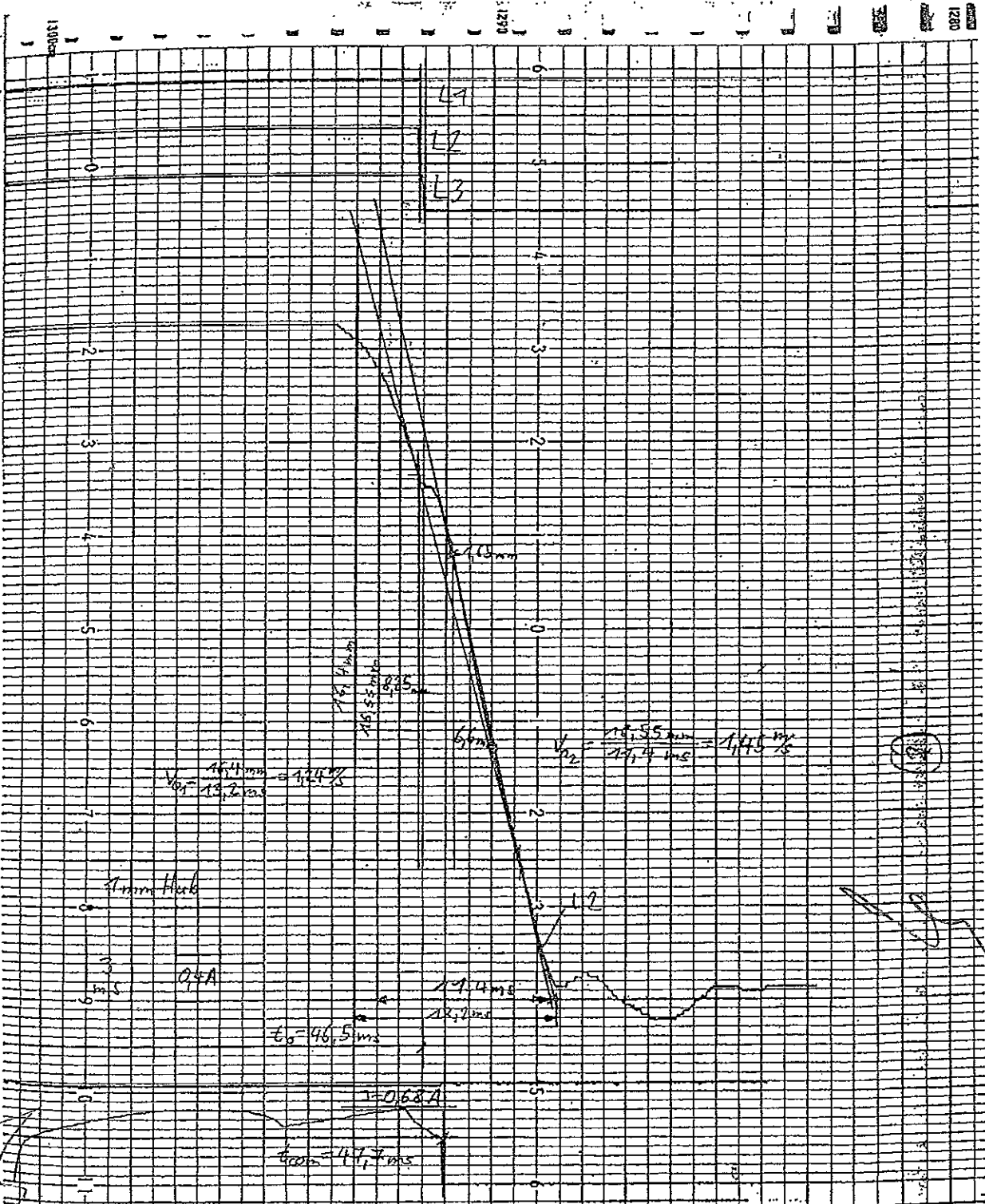

- Measuring point: Insulated coupling rod in phase L2
  - Operating speed measured:  $V_{02} = 1.24 \text{ m/s}$ ,  $V_{02} = 1.45 \text{ m/s}$  at  $U = 1.0 \times U_a$
- For the speed calculation, an enlarged similar triangle was used in order to increase the accuracy of the travel and time measurement.

КОПИО С ОРИГИНАЛА



(

(

**Results of measurements during the mechanical endurance test**

**a/b) Opening and closing time:**

Operating time [ms] U <sub>a</sub> = 220 V DC	U [V]	t <sub>01</sub> (opening)			t <sub>c</sub> (closing)		
		0.7 x U <sub>a</sub>	1.0 x U <sub>a</sub>	1.1 x U <sub>a</sub>	0.85 x U <sub>a</sub>	1.0 x U <sub>a</sub>	1.1 x U <sub>a</sub>
Number of operations: 2 000	t [ms]	62.1	47.1	44.7	68.4	64.5	62.4
Number of operations: 4 000	t [ms]	62.7	47.4	44.7	69.0	64.2	62.4
Number of operations: 6 000	t [ms]	63.0	47.7	45.0	69.6	65.1	62.7
Number of operations: 8 000	t [ms]	63.0	47.7	45.0	69.3	64.8	62.4

**d) Time spread between the breaker poles:**

The time spread between the breaker poles on closing and on opening of the circuit-breaker was measured to < 2 ms.

**e) Charging time of the motorized operating mechanism:**

Motor voltage U <sub>a</sub> = 220 V DC	charging time after O-C operation [ s ]		
	U = 0.85 x U <sub>a</sub> = 187 V DC	U = 1.0 x U <sub>a</sub> = 220 V DC	U = 1.1 x U <sub>a</sub> = 242 V DC
Number of operations: 2 000	4.01	3.10	2.97
Number of operations: 4 000	4.21	3.30	3.00
Number of operations: 6 000	5.73	3.89	3.21
Number of operations: 8 000	4.92	3.62	3.11

**m) Other important characteristics - contact travel:**

Contact travel in L2	Total Travel [mm]
Number of operations: 2 000	14.4
Number of operations: 4 000	14.3
Number of operations: 6 000	14.2
Number of operations: 8 000	14.2

**l) Time-travel chart with opening and closing speed:**

Speed in [m/s]; at U <sub>a</sub> = 220 V DC L2	V <sub>01</sub>	V <sub>02</sub>	V <sub>c</sub>
	(8.25 mm)	(6.60 mm)	(3.30 mm)
Number of operations: 2 000	1.19	1.49	0.88
Number of operations: 4 000	1.13	1.42	0.84
Number of operations: 6 000	1.12	1.38	0.85
Number of operations: 8 000	1.10	1.38	0.89

The deviations from the measured mechanical time travel charts are in the allowable limits of the reference mechanical travel characteristics.

2011.07.01



( )

( )

**Results of measurements after the mechanical endurance test**

Number of operations: counter: 10024

**a/b) Opening and closing time:**

Ua = 220 V DC

Operating time [ms]

- measured during the 5 x CO operations
- at the minimum supply voltage
  - at the rated supply voltage
  - at the maximum supply voltage

U [V]	t <sub>o</sub> (opening)			t <sub>c</sub> (closing)		
	0.7 x Ua	1.0 x Ua	1.1 x Ua	0.85 x Ua	1.0 x Ua	1.1 x Ua
t [ms]	63.3	47.4	45.0	68.7	64.2	62.1
	63.3	47.4	45.3	69.0	64.5	62.7
	62.4	47.1	45.0	69.0	64.5	62.4
	63.0	47.4	45.0	68.4	64.5	62.7
	63.0	47.7	45.0	69.3	64.5	62.1

**d) Time spread between the breaker poles:**

The time spread between the breaker poles on closing and on opening of the circuit-breaker was measured to < 2 ms.

**e/f) Charging time and power consumption of the motorized operating mechanism:**

Rated voltage: Ua = 220 V DC

Measured values:

Measured during the 5 x CO operations

- at the minimum supply voltage
- at the rated supply voltage
- at the maximum supply voltage

motor voltage	charging time after O-C operation [s]					current consumption [A]					power consumption [W]				
	3.96	4.39	4.60	4.55	4.58	0.98	1.04	1.05	1.06	1.10	183	194	196	198	206
U = 0.85 x Ua = 187 V DC															
U = 1.0 x Ua = 220 V DC	3.50	3.46	3.40	3.40	3.32	1.12	1.07	1.05	1.05	1.00	246	235	231	231	220
U = 1.1 x Ua = 242 V DC	2.91	2.88	2.86	2.87	2.90	1.04	1.05	1.05	1.05	1.04	252	254	254	254	252

**ВАЖНО С ОДМЪЛНАТА**



(

(



**g) Consumption of the tripping devices:**

Measured during the 5 x CO operations

- at the minimum supply voltage
- at the rated supply voltage
- at the maximum supply voltage

Rated operating voltage $U_a$	Shunt-release ON -MC					Shunt-release OFF -MO1				
	220 V DC					220 V DC				
Current at minimum supply voltage [ A ]	0.68	0.68	0.68	0.68	0.68	0.52	0.48	0.52	0.52	0.52
Current at rated supply voltage [ A ]	0.84	0.84	0.84	0.84	0.84	0.68	0.68	0.68	0.68	0.68
Current at maximum supply voltage [ A ]	0.96	0.92	0.92	0.92	0.92	0.76	0.76	0.76	0.76	0.76

**h) Duration of closing and opening command impulse:**

Measured during the 5 x CO operations

- at the minimum supply voltage
- at the rated supply voltage
- at the maximum supply voltage

Duration of command impulse at	Shunt-release ON -MC					Shunt-release OFF -MO1				
	Supply Voltage					Supply Voltage				
at minimum supply voltage [ ms ]	72.6	72.9	71.7	72.6	72.9	62.1	63.3	61.5	62.7	63.0
at rated supply voltage [ ms ]	69.6	69.9	69.9	69.9	69.9	50.1	50.1	50.7	50.1	50.7
at maximum supply voltage [ ms ]	65.7	69.3	69.0	69.3	69.0	51.0	51.0	50.7	51.0	51.0

**k) Resistance of the main conductors:**

Measuring points:

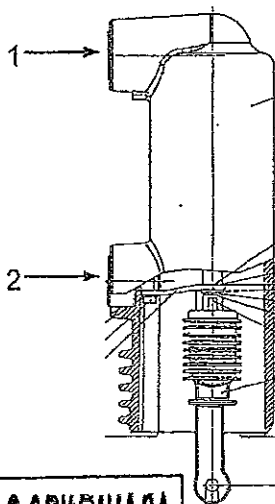

**ВЪРНО С ОРЪЖИКАЛА**

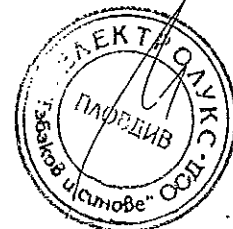

(

(

Contact resistance measured during the 5 x CO operations at the minimum supply voltage of the coils:

Measuring points	L1 μΩ	L2 μΩ	L3 μΩ
1-2	15.3	15.3	15.7

Contact resistance measured during the 5 x CO operations at the rated supply voltage of the coils:

Measuring points	L1 μΩ	L2 μΩ	L3 μΩ
1-2	15.3	15.3	15.6

Contact resistance measured during the 5 x CO operations at the maximum supply voltage of the coils:

Measuring points	L1 μΩ	L2 μΩ	L3 μΩ
1-2	15.3	15.3	15.7

l) Time-travel chart with opening and closing speed: See diagram 2.1 and 2.2

Speed in [m/s]; U<sub>a</sub> = 220 V DC  
at U = 1.0 x U<sub>a</sub>

	V <sub>o1</sub>	V <sub>o2</sub>	V <sub>c</sub>
L2	1.12	1.42	0.89

The deviations from the measured mechanical time travel charts are in the allowable limits of the reference mechanical travel characteristics.

- Vo1: opening speed considered 8.25 mm after the separation in the main contacts of phase L2.
- Vo2: opening speed considered between 1.65 and 8.25 mm after the separation in the main contacts of phase L2.
- Vc: closing speed considered 3.3 mm before the touching in the main contacts of phase L2.

m) Other important characteristics:

▪ Contact travel:

	L1	L2	L3
Total Travel [mm]	14.2	14.2	14.3
Cont.-travel [mm]	11.8	11.3	11.2
Contact-spring travel [mm]	2.4	2.9	3.1

- Check of vacuum of interrupters: 60 kV DC ok
- Verification of the rated operating sequence: O-0.3s-CO-3min-CO at rated voltage ok
- Ambient atmospheric conditions: Date: 21<sup>st</sup> May 2003, ambient air temperature: approx. 22.5°C

ВЯРНО С ОПРИГНАЛА



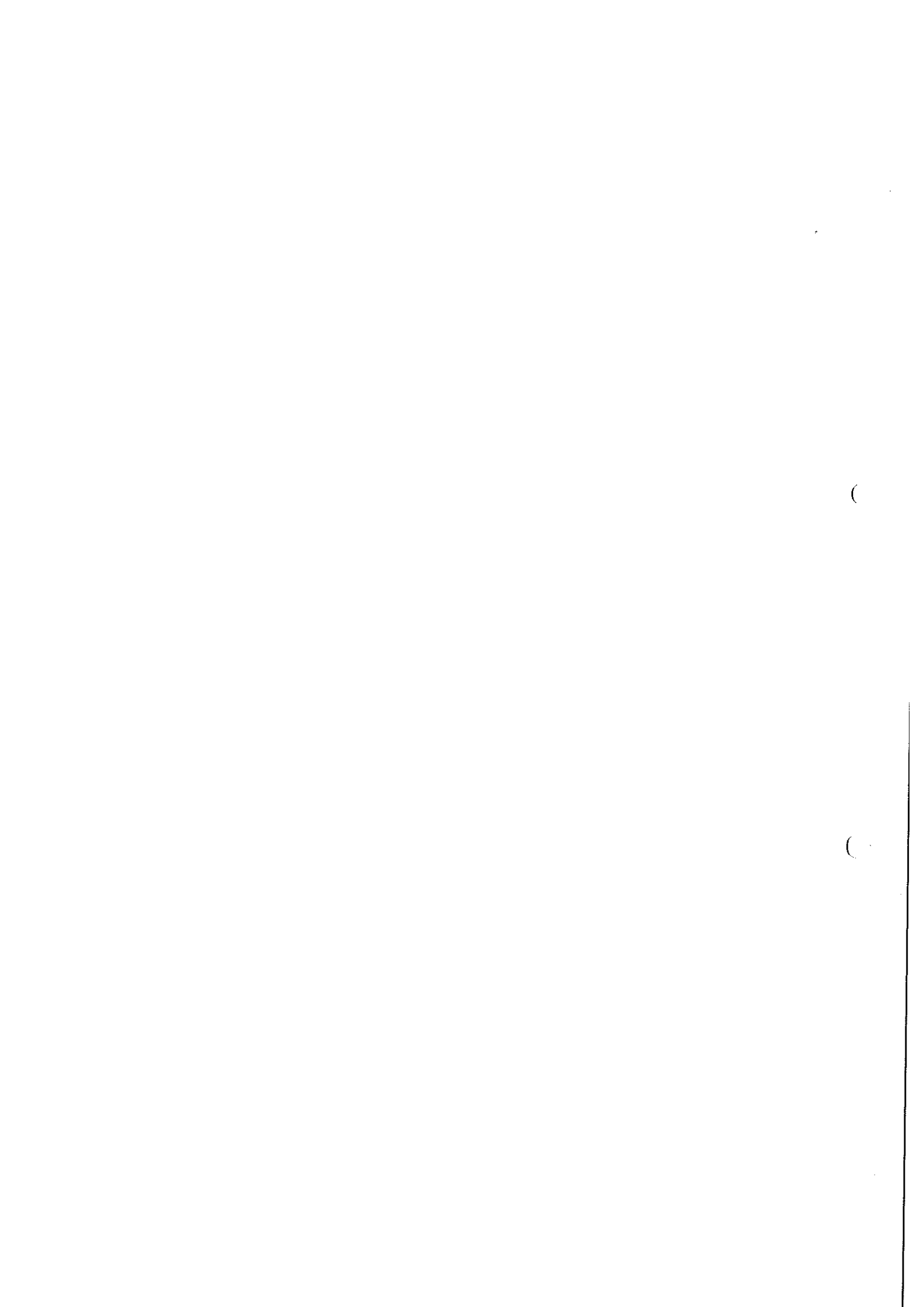
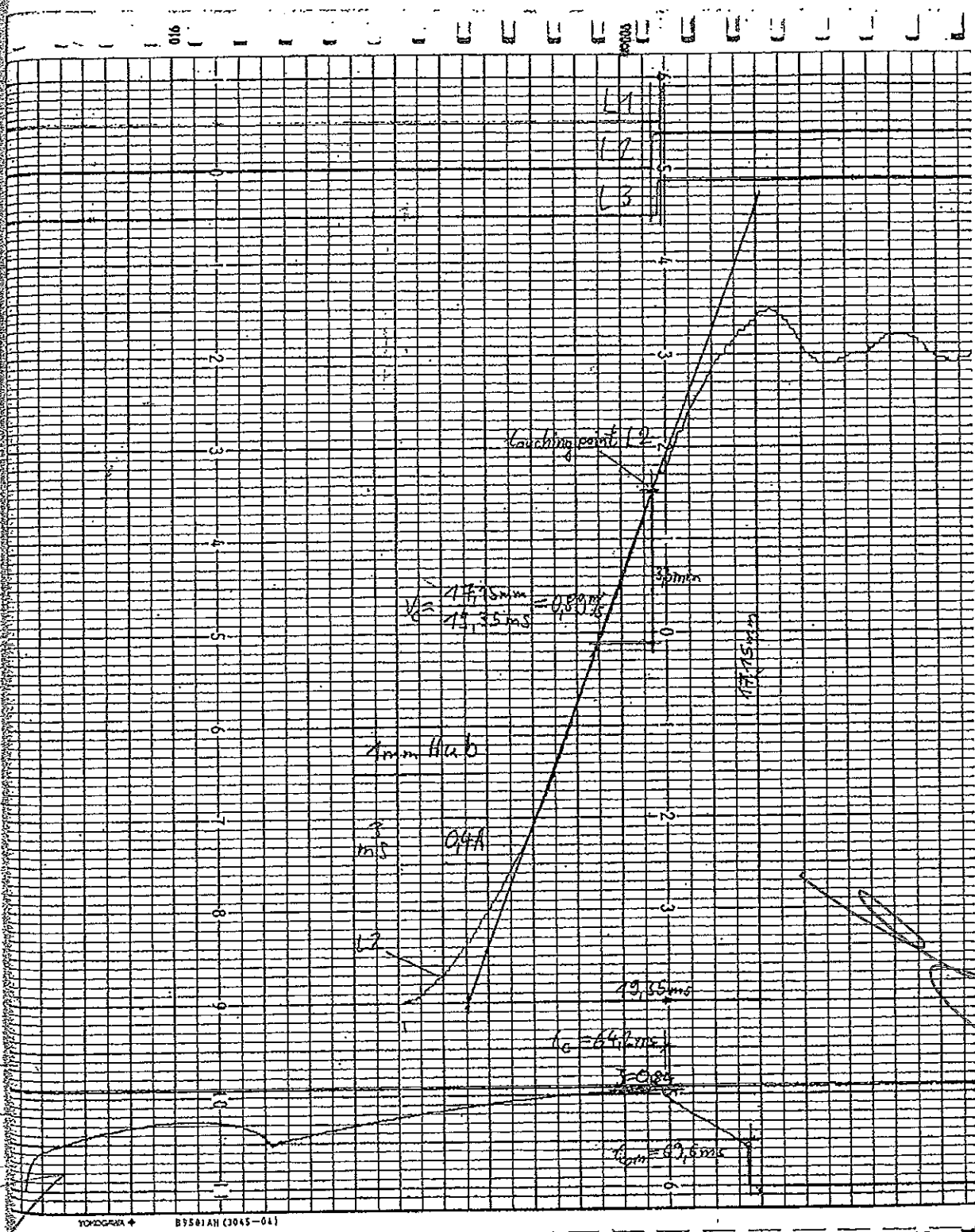

Diagram 2.1: Measurement of the operating speed after the mechanical endurance test



Measuring point: Insulated coupling rod in phase L2  
 Operating speed measured:  $v_c = 0.89$  m/s at  $U = 1.0 \times U_a$   
 For the speed calculation, an enlarged similar triangle was used in order to increase the accuracy of the travel and time measurement.

ВРАНО С ОРЪГИНАЛА



C

C

Diagram 2.2: Measurement of the operating speed after the mechanical endurance test

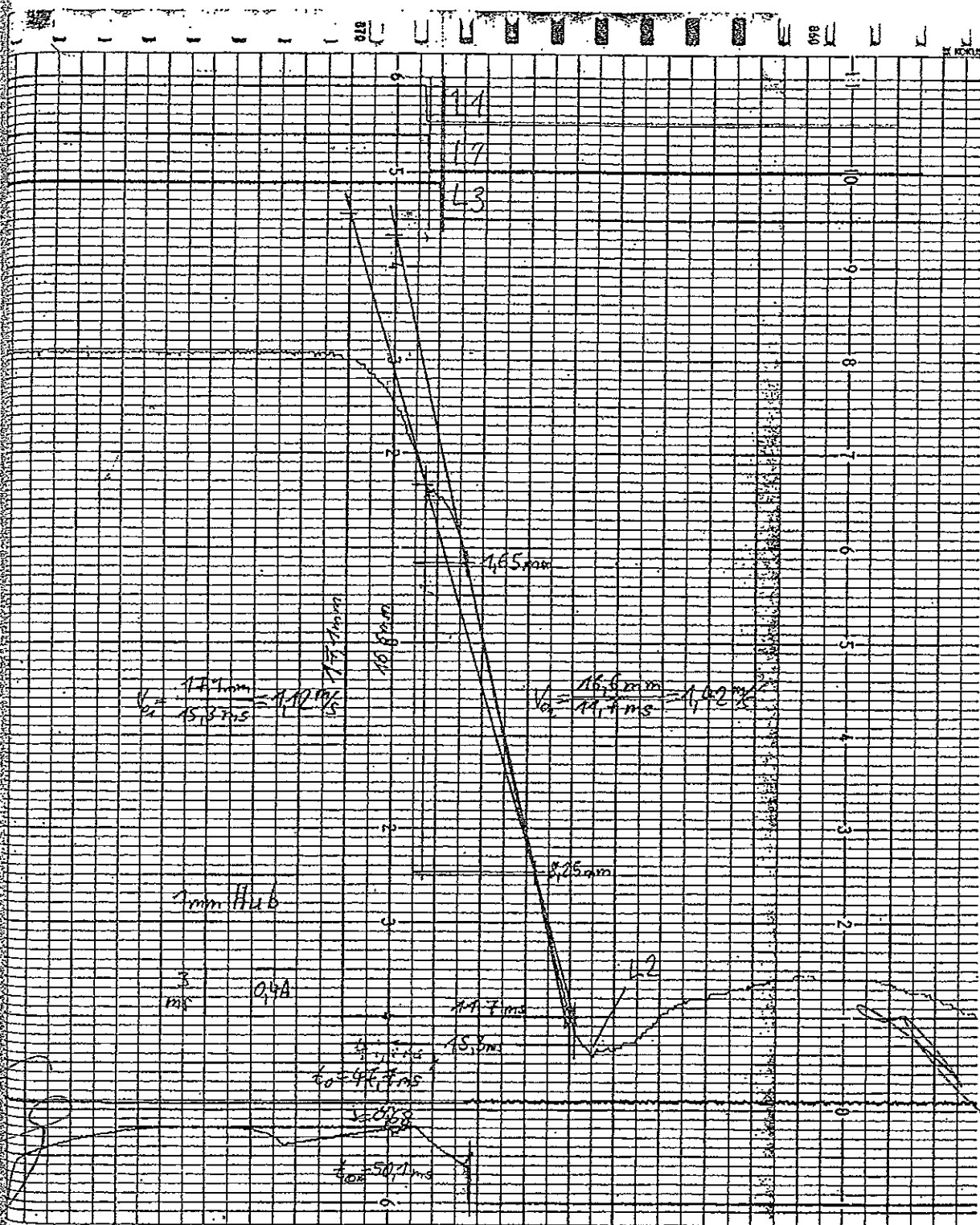

Measuring point: Insulated coupling rod in phase L2

Operating speed measured:  $V_{01} = 1.12 \text{ m/s}$ ,  $V_{02} = 1.42 \text{ m/s}$  at  $U = 1.0 \times U_a$

For the speed calculation, an enlarged similar triangle was used in order to increase the accuracy of the travel and time measurement.

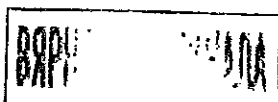

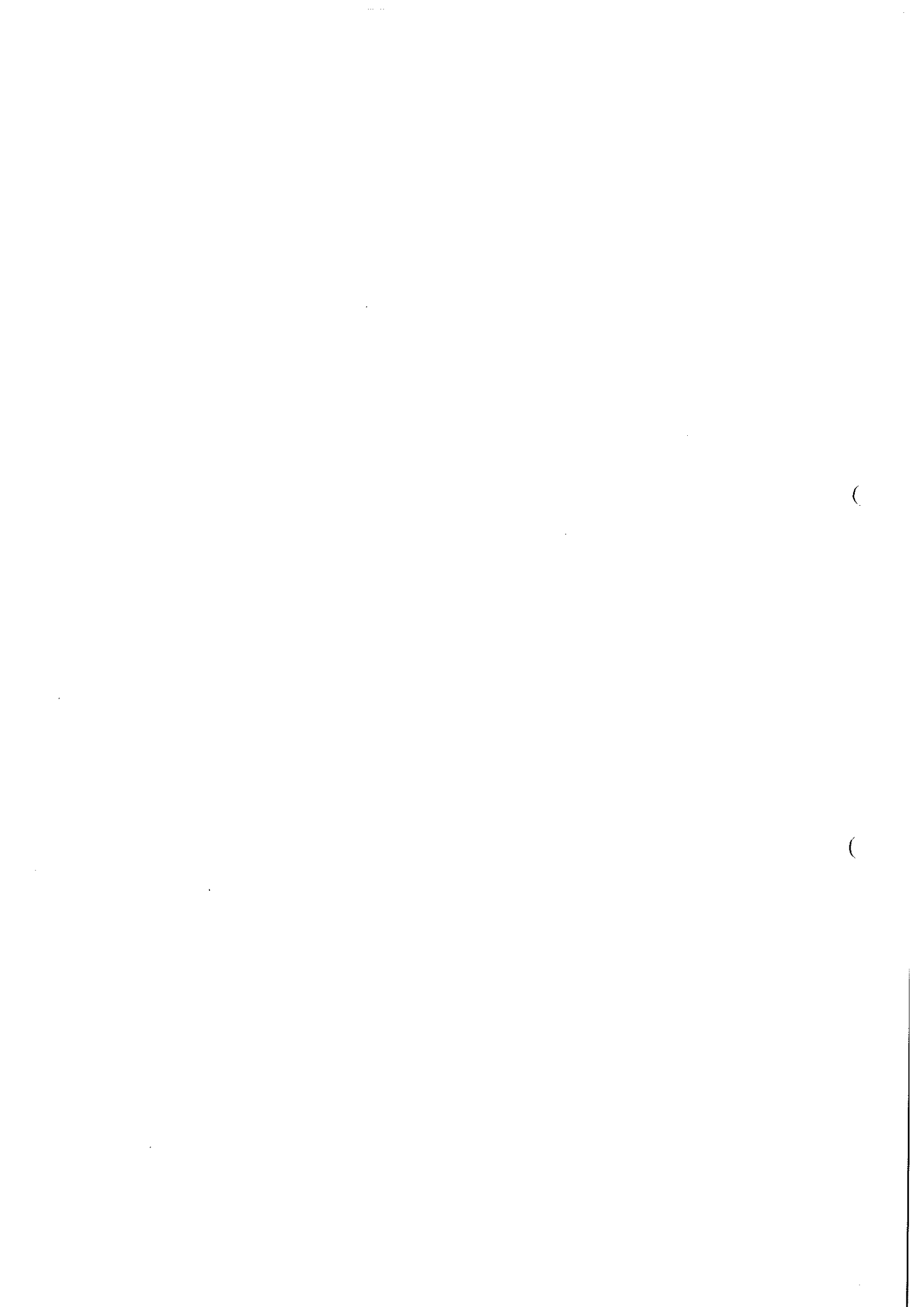



## Evaluation of the measurements before and after the test program

The reference mechanical travel characteristic was recorded at the rated supply voltage before the endurance test. All measured travel-curves fall within the limits of the two envelope curves which characterize the allowable deviations from the reference curve.

All characteristics measured before and after the test program do not show unacceptable variations.

The circuit-breaker operated only on command and did not operate without command.

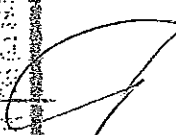
  
ВЯРНО С

(

(

**Measuring Instrument Record**

Test job no.: 940  
 Object tested: VD4 17.12.32  
 Date of test: 28<sup>th</sup> April – 21<sup>st</sup> May 2003  
 Test report: PEHLA 0316Ra  
 Test operator: Piglas/Schöttler

Instrument	Ident.-no.	Measuring	Remarks
Microohmmeter MO2A 50	ELK 001111	20μΩ / 200μΩ	Resistance measurement
resistive travel pick-up type lino pot Ts 50 502	ELK 001124	5 kΩ	Travel time measurement
DM 7100 Transient memory	ELK 000467	±2 V / full scale 50μs/word, channel 4 ( 12 bit)	
YEW-3063 Multi-pen	ELK 000462	0.25 V/cm-vernier 10 cm/min, channel 4	
Slide caliper rule	LAE 002162	0 - 300 mm	
Shunt 1A/150mV	ELK 000435	1A/150mV	Current measurement (MC/MO1)
DM 7100 Transient memory	ELK 000467	±20/0.2 V/full scale 50 μsec/word/10ms/word channel 1, 2, 3, 8 (8 bit)	Operating time measurement,
YEW-3063 Multi-pen	ELK 000462	Channel 1, 2, 3, 8, 0.25/1 V/cm-cal/vernier 10 cm/min	
Electronic time clock	ELK 001231	0-100s	Charging time measurement
Unigor 6E	ELK 000389	1 A	Motor current measurement
Vidar-Vacuum- Checker-Test device	DRU 000026	40/60kV DC	Vacuum-Checker-Test
BBC MA 5D	ELK 000362	300 V DC	Voltage measurement
Hygrometer Hygronom	FEU 000022	-30°C - +50°C	temperature measurement

ВАРНО С. ОРИГОНАЛ



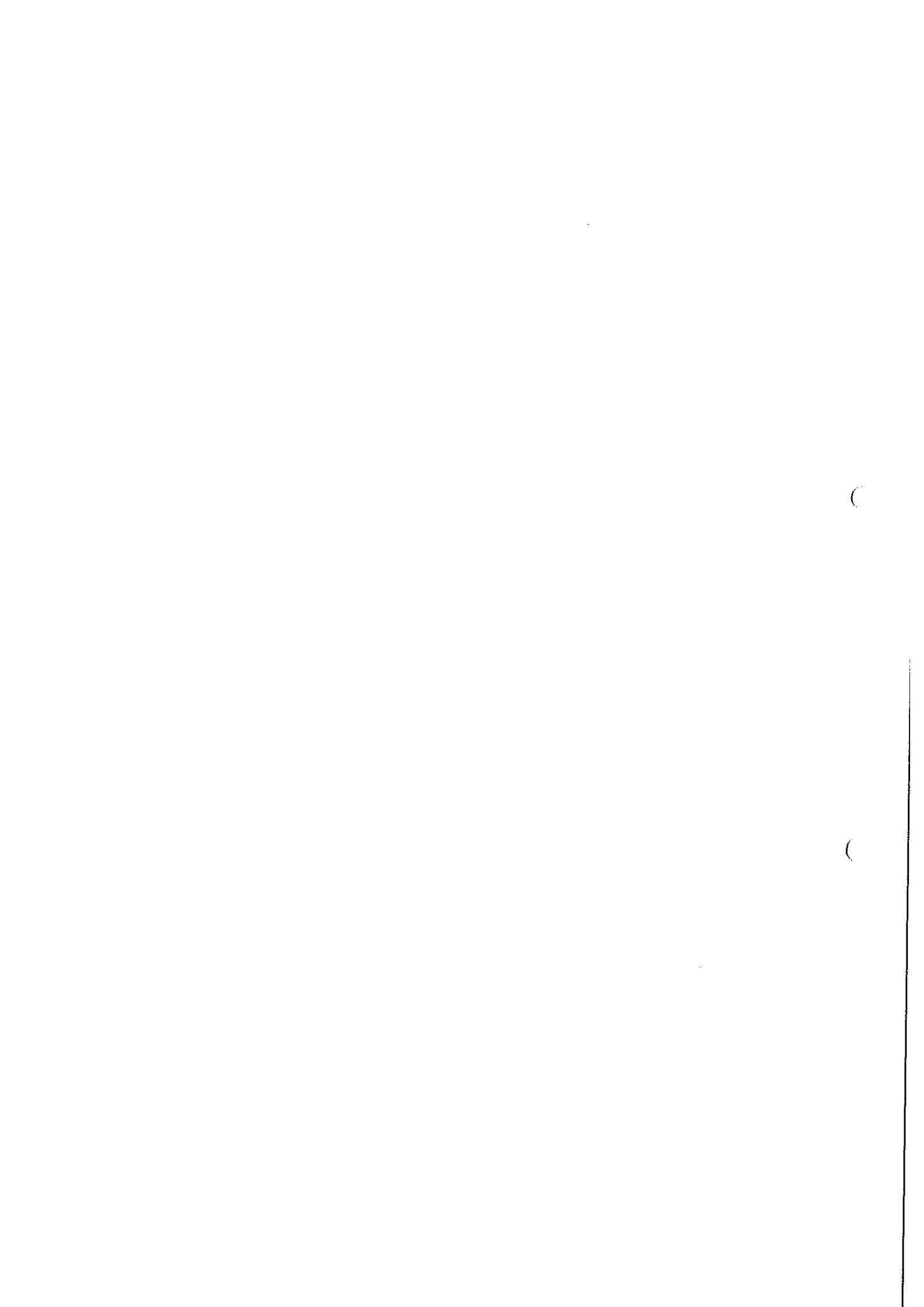

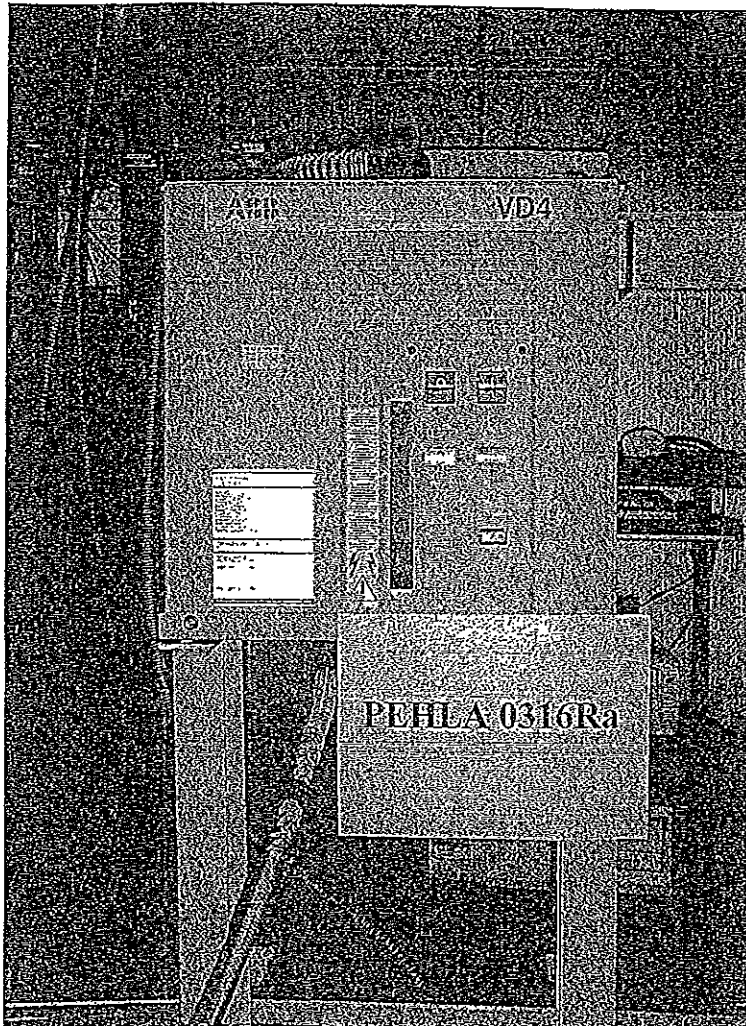

Figure 1: Test object

ВЯРНО С ОРГИНАЛА



C

C

# PEHLA

GESELLSCHAFT FÜR ELEKTRISCHE HOCHLEISTUNGSPRÜFUNGEN  
Member of the Short-Circuit-Testing Liaison (STL)

## Test Report

Report No.: 0231Ra

Copy No.: 1

Contents: 61 Sheets

Equipment under test: Vacuum circuit-breaker type VD4.17.12.32 (17.5 kV, 1250 A, 31.5 kA) equipped with vacuum interrupters type VG4S.

**Manufacturer:**

Circuit-breaker: ABB T&D SpA, Divisione Sace T.M.S, Via Friuli, 4 – 24044 Dalmine (BG), Italy

Pole parts inclusive

vacuum interrupters: ABB Calor Emag Mittelspannung GmbH, Oberhausener Str. 33, 40472 Ratingen, Germany

Client: ABB T&D SpA, Divisione Sace T.M.S, Via Friuli, 4 – 24044 Dalmine (BG), Italy

Testing station: PEHLA-Testing Laboratory Ratingen

Date of test: 19<sup>th</sup> December 2002

**Applied test specifications:**

The tests have been carried out in accordance with the client's instructions.

Test procedure and test parameters were based on:

IEC 62271-100/2001-05, Clauses 6.106.1, 6.106.2, 6.106.3, 6.106.4, 6.106.5, 6.108.3

STL-Guide to IEC 60056: 4<sup>th</sup> Edition: 1987, Amendment Slip No. 2

**Tests performed:**

Basic short-circuit test-duties T10 – T100 and double earth fault breaking test.

No-load operations and measurement of the resistance of the pole parts before and after the tests.

Power-frequency withstand voltage test with 38.0 kV – 1 min before and after the tests.

Measurement of the time-travel characteristic before and after the tests.

For further details see sheet no. 3.

**Test results:**

The vacuum circuit-breaker passed the mentioned tests successfully.



GESELLSCHAFT FÜR ELEKTRISCHE  
HOCHLEISTUNGSPRÜFUNGEN

Technical Committee

Mannheim, 27<sup>th</sup> March 2003

The test results relate only to the items tested.

Without a written permission of PEHLA it is not allowed to make reproduction in extracts of this document. Copying the cover sheet accompanied by sheet 2 and the sheets mentioned here is an exception.

ВЯРНО С ОРИГИНАЛА

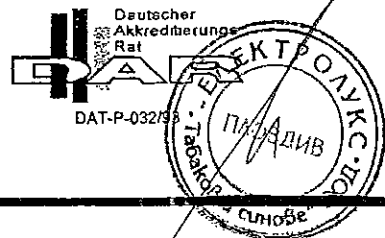

C

C



**Accreditation**

The PEHLA-Testing Laboratory Ratingen has been approved by the DATech (German accreditation body for technology) according to DIN EN ISO/IEC 17025 for tests in the field of high-voltage switchgear and controlgear and power engineering equipment (Registration-No. DAT-P-032/93).

Under reference to DIN EN ISO/IEC 17025 PEHLA states the following:

- The accreditation of the PEHLA-Testing Laboratory or any of its test reports by themselves in no way constitute or imply product approval by DATech or any other body.
- If someone refers to a test in an accredited PEHLA-Testing Laboratory this reference shall include the accreditation body, i.e. DATech, the relevant scope of the accreditation and the appropriate registration number.

**STL-Member**

PEHLA is foundation-member of the Short-Circuit Testing Liaison (STL) which has been founded in March 1969. STL is a forum for the international co-operation of the testing organisations with the further full members ASTA (GB), CESI (I), ESEF (F), KEMA (NL), SATS (N, S, AIR) and STLNA (USA). In the Framework of EC, STL has been recognised in 1992 by EOTC as agreement group.

**PEHLA-Documents****A Certificate**

is issued for type tests which have successfully been carried out in full compliance with the relevant specifications or standards and STL Guides valid at the time of the test.

For these tests the equipment under test must be clearly identified by technical description, drawings and additional specifications.

**A Test Document**

is issued for parts of type tests which have successfully been carried out in full compliance with the relevant specifications or standards and STL Guides valid at the time of test.

For these tests the equipment under test must be clearly identified by technical description, drawings and additional specifications.

**A Test Report**

is issued for all other tests which have been carried out according to specifications, standards or "PEHLA-Richtlinien" (PEHLA Guides) and/or clients instructions.

Similarly, this test report contains all test results, details of the conditions under which the tests were carried out, also details relating to the behaviour of the equipment during test, and its condition after the tests.

**Addresses:**

Office: PEHLA-Geschäftsstelle  
Hallenweg 40  
68219 Mannheim, Germany

Testing Station: PEHLA-Testing Laboratory Ratingen  
Oberhausener Str. 33  
40472 Ratingen, Germany

Manufacturer: ABB T&D SpA, Divisione SACE T.M.S.  
Via Friuli, 4  
24044 Dalmine (BG), Italy

ABB Calor Emag Mittelspannung GmbH  
Oberhausener Str. 33  
40472 Ratingen, Germany

Client: ABB T&D SpA, Divisione SACE T.M.S.  
Via Friuli, 4  
24044 Dalmine (BG), Italy

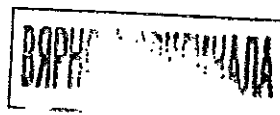

(

(

**Tests performed:**

Basic short-circuit test-duties and double earth fault breaking test.

Infeed by means of copper bars to the upper terminals of the circuit-breaker, lower terminals short-circuited and earthed.

T10: 3.39 kA at 18.7 kV / 3.46 kA at 17.5 kV / 3.41 kA at 18.7 kV / 3.43 kA at 17.8 kV  
(10 %  $I_{sc}$  O-0.3s-CO-3min-CO-5min-CO).

T30: 9.69 kA at 18.8 kV / 9.81 kA at 18.7 kV / 9.93 kA at 19.1 kV  
(30 %  $I_{sc}$  O-0.3s-CO-3min-CO).

T60: 19.1 kA at 18.0 kV / 18.7 kA at 17.7 kV / 18.7 kA at 18.0 kV / 19.2 kA at 18.2 kV  
(60 %  $I_{sc}$  O-0.3s-CO-3min-CO-8min-CO).

T100s: 32.6 kA at 18.6 kV / 32.0 kA at 17.6 kV / 31.6 kA at 19.5 kV  
(100%  $I_{sc}$  O-0.3 s-CO-3min-CO).

T100a: 33.3 kA (30.3% $_{DC-comp.}$ ) at 19.2 kV / 33.1 kA (27.9% $_{DC-comp.}$ ) at 19.4 kV /  
33.0 kA (26.7% $_{DC-comp.}$ ) at 19.2 kV / 33.1 kA (28.8% $_{DC-comp.}$ ) at 18.7 kV  
(100%  $I_{sc}$   $O_{asym}/O_{asym}/O_{asym}/O_{asym}$ ).

Double earth fault breaking test: 28.8 kA at 18.5 kV

No-load operations and measurement of the resistance of the pole parts before and after the tests.  
Power-frequency withstand voltage test with 38.0 kV – 1 min before and after the tests.  
Measurement of the time-travel characteristic before and after the tests.

ВЯРНІ АНАЛІЗ



(

(

**Table of Contents**

	Sheet
Test Report - Cover Sheet	1
Accreditation	2
Tests performed	3
Table of Contents	4
List of Test Participants	5
Technical Data of Test Object	6
List of Drawings	7
Drawings	8 - 10
Technical Data of Test Circuits	11 - 13
Principle Diagram of Three-phase Test Circuits	14
Principle Diagram of Single-phase Test Circuit	15
Short-Circuit Making and Breaking Tests T60	16
Oscillograms 0231Ra / 06 to 08	17 - 23
Short-Circuit Making and Breaking Tests T100s	24
Oscillograms 0231Ra / 10 to 11	25 - 29
Short-Circuit Making and Breaking Tests T100a	30
Oscillograms 0231Ra / 21 to 24	31 - 38
Short-Circuit Making and Breaking Tests T10	39
Oscillograms 0231Ra / 25 to 27	40 - 43
Short-Circuit Making and Breaking Tests T30	44
Oscillograms 0231Ra / 30 to 31	45 - 49
Double Earth Fault Breaking Test	50
Oscillogram 0231Ra / 35	51 - 52
Measurement of the Resistance Table of No-load Operations	53
Oscillograms 0231Ra / 002 to 02B, 032 to 32B, 036 to 36B	54 - 59
Photos	60 - 61

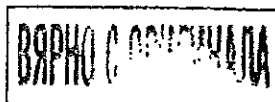

C

C

---

## List of Test Participants

### Representatives of the Test Committee:

Mr. G. Heit PEHLA-Testing Laboratory Mannheim, Germany

Mr. K. Hauck PEHLA-Testing Laboratory Ratingen, Germany

### Test Engineer:

Mr. K. Hauck PEHLA-Testing Laboratory Ratingen, Germany

### Representatives of the Client:

Mr. S. Magoni ABB T&D SpA, Division SACE T.M.S., Italy

Mr. C. Manzoni ABB T&D SpA, Division SACE T.M.S., Italy

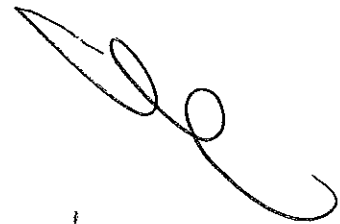

ВЕРНО С ОРИГИНАЛА



(

(



**Technical Data of Test Object****Switching Device – Circuit-Breaker**

Ratings assigned by the manufacturer

**Test Object:** Vacuum circuit-breaker  
**Type:** VD4.17.12.32  
**Manufacturer:**  
 Circuit-breaker: ABB T&D SpA, Divisione Sace T.M.S, Via Friuli, 4 – 24044 Dalmine (BG), Italy  
 Pole parts including vacuum interrupters: ABB Calor Emag Mittelspannung GmbH, Oberhausener Str. 33, 40472 Ratingen, Germany  
**Serial-No.:** AC00043879 **Year of manufacture:** 2002  
**Drawing No.:** see sheet 7  
**Vacuum interrupter:** Type: VG4S L1: No. 3690, L2: No. 3559, L3: No. 5133  
**Drawing No.:** see sheet 7

Rated voltage	17.5 kV
Rated lightning impulse withstand voltage	95 kV
Rated switching impulse withstand voltage	- kV
Rated power frequency withstand voltage	38 kV
Rated frequency	50 Hz
Rated normal current	1250 A
Rated peak withstand current	80 kA
Rated short-time withstand current	31.5 kA
Rated duration of short-circuit	3 s
Rated short-circuit breaking current at 17.5 kV	31.5 kA
D.C. component	30 %
Rated short-circuit making current at 17.5 kV	80 kA
Rated transient recovery voltage:	
Peak value	30 kV
Rate of rise	0.42 kV/μs
First-pole-to-clear-factor	1.5
Rated operating sequence	O-0.3s-CO-3min-CO
Arc extinguishing medium	vacuum
Number of poles	3
Number of units per pole	1
Rated opening time	≥ 45 ms
Rated closing time	approx. 60 ms
Rated voltage of trip coil	220 V-DC
Rated voltage of closing coil	220 V-DC
Rated supply voltage	220 V-DC
Rated frequency of supply voltage	- Hz

**Essential characteristics:**

Motor Drive Type 701 921/804, Serial No. CA 6DC L02 D (EL1)

Date of receipt of test object: 11<sup>th</sup> November 2002

ВЯРНО С ОРИГИНАЛА



(

(



(

(





(

(

\_\_\_\_\_



C

C





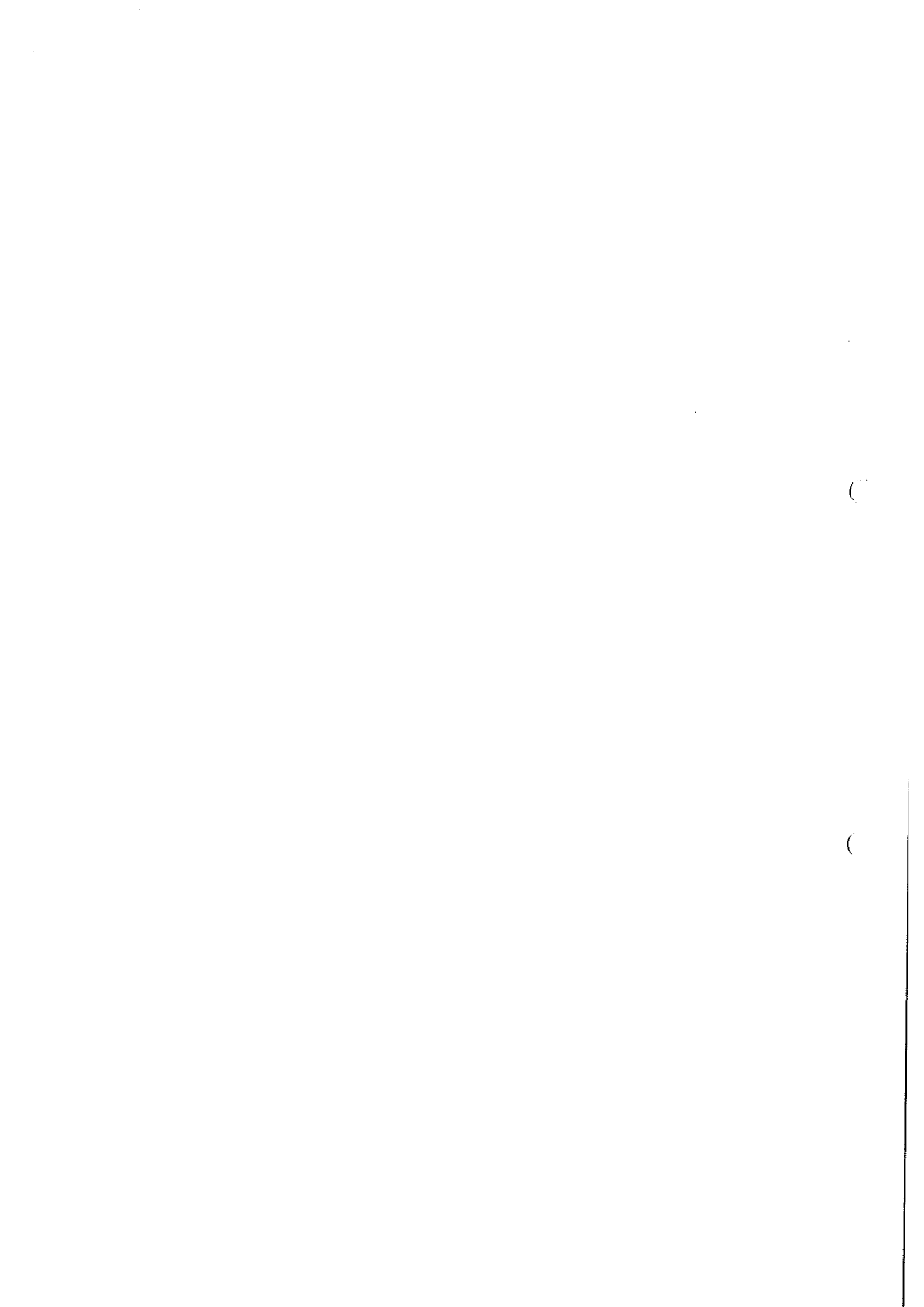

**Technical Data of Test Circuits**

Test	Basic Short-Circuit Test-Duty	T60		T100	
Test No.	0231Ra	06 -- 08		09 - 24	
Number of phases	(test circuit)	3		3	
Rated voltage	kV	17.5		17.5	
Number of poles or phases	(test object)	3		3	
Voltage distribution	%	-		-	
Power frequency	Hz	50		50	
Power factor	cos φ	≤ 0.15		≤ 0.15	
Earthing conditions	Generator / System Transformer Short-circuit point	earthed via 5 kΩ not earthed earthed		earthed via 5 kΩ not earthed earthed	
Short-circuit breaking current	kA	18.9		31.5	
Test frequency	Hz	-		-	
Crest value of injected current	kA	-		-	
Corresponding test frequency	Hz	-		-	
<b>Transient Recovery Voltage</b>		required values	actual values	required values	actual values
TRV peak value $u_c$	kV	32.0	37.3	30.0	29.6
Time $t_2$ or $t_3$	μs	31.0	36.0	71.0	64.0
Time delay $t_d$	μs	-	-	-	-
Rate-of-rise $u_1 / t_1$ or $u_c / t_3$	kV/μs	1.04	1.04	0.42	0.46
Voltage $u_1$	kV	-	-	-	-
Time $t_1$	μs	-	-	-	-
First peak $u_{1f}$	kV	-	-	-	-
Time $t_{1f}$	μs	-	-	-	-
Rate of rise $u_{1f}/t_{1f}$	kV/μs	-	-	-	-
Surge impedance $Z_L$	Ω	-	-	-	-
Time Delay $t_{dL}$	μs	-	-	-	-
Crest value $u_T$	kV	-	-	-	-
Crest value $u_c$	kV	-	-	-	-
		-	-	-	-
Voltage measurements		-	Dividers 4.5 MΩ / 10 kΩ	-	Dividers 4.5 MΩ / 10 kΩ
Current measurements		-	Shunts 37.6 μΩ	-	Shunts 37.6 μΩ

Remarks:

ВЯРНО С ОРИГИНАЛА



(

(

**Technical Data of Test Circuits**

Test	Basic Short-Circuit Test	T10		T30	
Test No.	0231Ra	25 - 27		28 - 31	
Number of phases	(test circuit)	3		3	
Rated voltage	kV	17.5		17.5	
Number of poles or phases	(test object)	3		3	
Voltage distribution	%	-		-	
Power frequency	Hz	50		50	
Power factor	cos φ	≤ 0.15		≤ 0.15	
Earthing conditions	Generator / System Transformer Short-circuit point	earthed via 5 kΩ not earthed earthed		earthed via 5 kΩ not earthed earthed	
Short-circuit breaking current	kA	3.15		9.45	
Test frequency	Hz	-		-	
Crest value of injected current	kA	-		-	
Corresponding test frequency	Hz	-		-	
<b>Transient Recovery Voltage</b>		required values	actual values	required values	actual values
TRV peak value $u_c$	kV	32.0	35.0	32.0	35.4
Time $t_2$ or $t_3$	μs	15.0	56.5 * <sup>1</sup>	15.0	49.0 * <sup>1</sup>
Time delay $t_d$	μs	-	-	-	-
Rate-of-rise $u_1 / t_1$ or $u_c / t_3$	kV/μs	2.14	0.62	2.14	0.72
Voltage $u_1$	kV	-	-	-	-
Time $t_1$	μs	-	-	-	-
First peak $u_L$	kV	-	-	-	-
Time $t_L$	μs	-	-	-	-
Rate of rise $u_L / t_L$	kV/μs	-	-	-	-
Surge impedance $Z_L$	Ω	-	-	-	-
Time Delay $t_{dL}$	μs	-	-	-	-
Crest value $u_T$	kV	-	-	-	-
Crest value $u_c$	kV	-	-	-	-
Voltage measurements		-	Dividers 4.5 MΩ / 10 kΩ	-	Dividers 4.5 MΩ / 10 kΩ
Current measurements		-	Shunts 37.6 μΩ	-	Shunts 37.6 μΩ

**Remarks:**

\*<sup>1</sup> Due to limitations of the test plant, the length of time  $t_3$  of the TRV is greater than the rated value.

ВЕРНО С ОРИГИНАЛОМ



C

C

---

**Technical Data of Test Circuits**

Test	Basic Short-Circuit Test	Double earth fault test			
Test No.	0231Ra	35			
Number of phases	(test circuit)	2			
Rated voltage	kV	17.5			
Number of poles or phases	(test object)	1			
Voltage distribution	%	-			
Power frequency	Hz	50			
Power factor	cos φ	≤ 0.15			
Earthing conditions	Generator / System	earthed via 5 kΩ			
	Transformer	not earthed			
	Short-circuit point	earthed			
Short-circuit breaking current	kA	27.4			
Test frequency	Hz	-			
Crest value of injected current	kA	-			
Corresponding test frequency	Hz	-			
<b>Transient Recovery Voltage</b>		required values	actual values	required values	actual values
TRV peak value $u_c$	kV	34.6	34.1	-	-
Time $t_2$ or $t_3$	μs	81.9	77.5	-	-
Time delay $t_d$	μs	-	-	-	-
Rate-of-rise $u_1 / t_1$ or $u_c / t_3$	kV/μs	0.42	0.44	-	-
Voltage $u_1$	kV	-	-	-	-
Time $t_1$	μs	-	-	-	-
First peak $u_L$	kV	-	-	-	-
Time $t_L$	μs	-	-	-	-
Rate of rise $u_L / t_L$	kV/μs	-	-	-	-
Surge impedance $Z_L$	Ω	-	-	-	-
Time Delay $t_{dL}$	μs	-	-	-	-
Crest value $u_T$	kV	-	-	-	-
Crest value $u_c$	kV	-	-	-	-
Voltage measurements		-	Dividers	-	-
		-	4.5 MΩ /	-	-
			10 kΩ		
Current measurements		-	Shunts	-	-
		-	37.6 μΩ	-	-

Remarks: -

**ВЯРНО С ОРИГИНАЛА**



(

(

|



### Principle Diagram of Three-phase Test Circuits

Basic Short-circuit Test-Duties T10 – T100

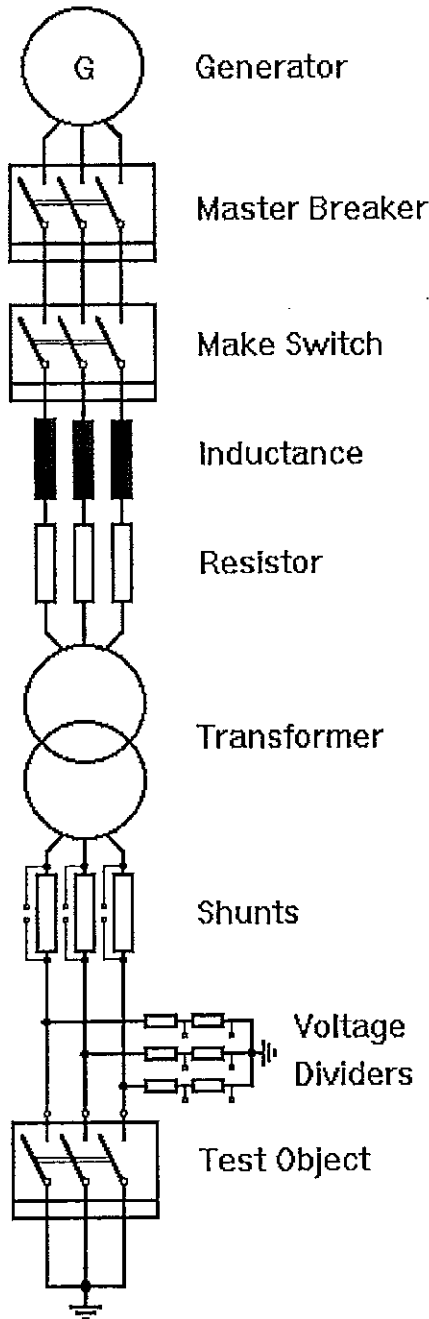

ВЯРНО С ОРИГИНАЛА





**Principle Diagram of Single-phase Test Circuit**

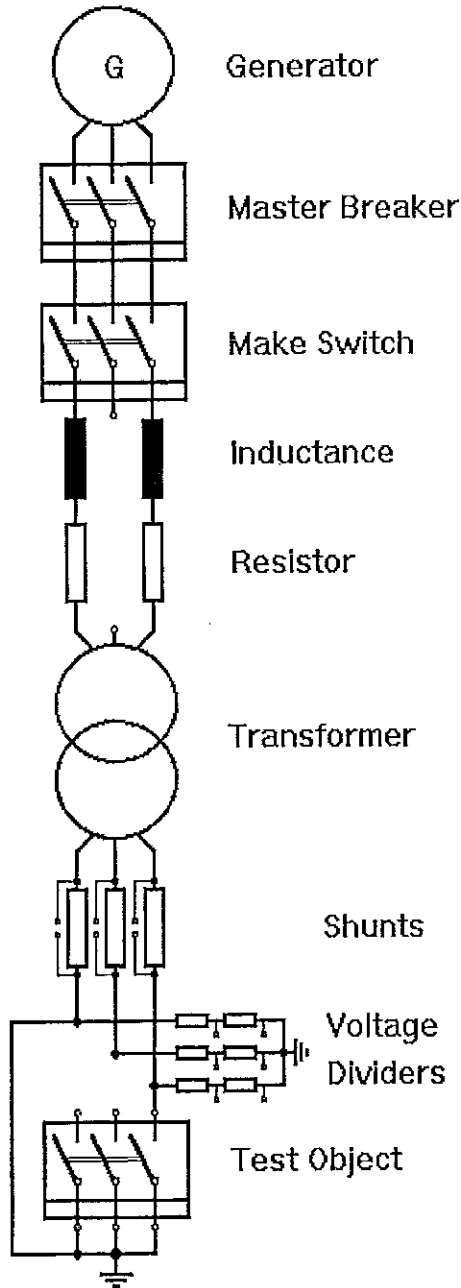

ВЕРНО С ОРИГИНАЛОМ



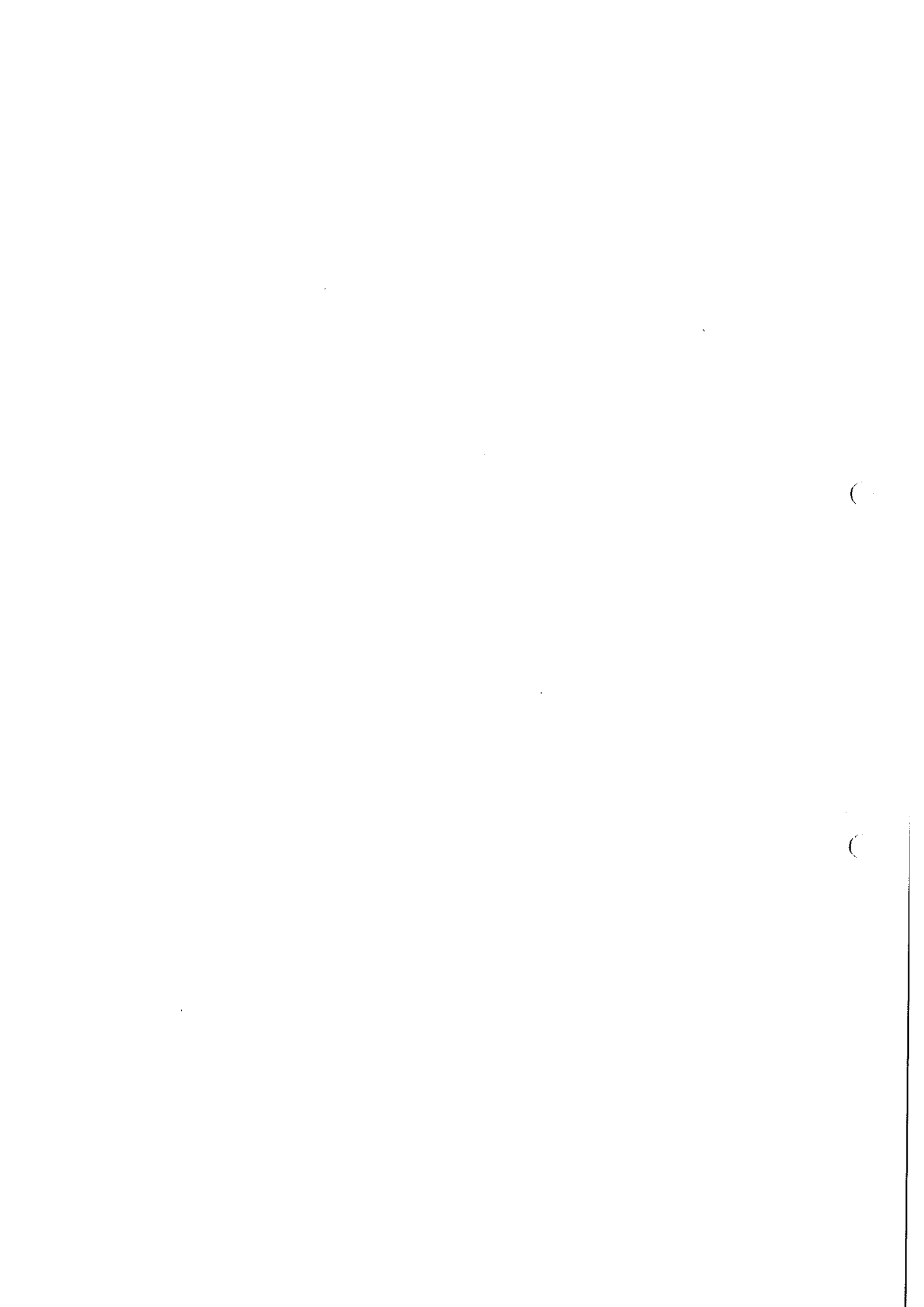

**Short-Circuit Making and Breaking Tests**  
Circuit-breaker

**Test duty:** T60  
**Date of test:** 19<sup>th</sup> December 2002  
**Condition of test object before test:** Factory new.  
**Connections to test object:** By means of copper bars to the upper terminals of the circuit-breaker. Lower terminals of the circuit-breaker short-circuited and earthed  
**Arc extinguishing medium:** Vacuum

Test No. PEHLA 0231Ra				06	07	08	
Operating sequence				O – 0.3s – CO – 3min – CO – 8min – CO			
Applied voltage	kV			-	18.4	17.4	18.4
Short-circuit making current	kA	L1		-	44.3	34.1	35.2
		L2		-	32.9	46.5	47.4
		L3		-	49.6	50.7	52.2
Short-circuit breaking current	kA	Short-circuit current	L1	19.1	18.5	18.4	18.9
			L2	19.0	19.0	18.9	19.4
			L3	19.3	18.6	18.8	19.3
		Average value	kA	19.1	18.7	18.7	19.2
d.c. component	%		L1	< 20	< 20	< 20	< 20
			L2	< 20	< 20	< 20	< 20
			L3	< 20	< 20	< 20	< 20
Recovery voltage	kV		L1	10.6	10.2	10.4	10.4
			L2	10.6	10.2	10.4	10.6
			L3	10.4	10.3	10.4	10.4
Average value (phase-to-phase)	kV	-	18.0	17.7	18.0	18.2	
Transient Recovery Voltage (TRV), first-pole-to-clear	kV			-	-	-	-
				31.8	31.3	38.3	38.8
Arcing time	ms		L1	9.1	7.0	2.4	1.8
			L2	4.6	2.0	7.2	7.0
			L3	9.3	6.8	7.0	6.8
Closing time	ms			-	62.9	65.3	65.5
Opening time	ms			62.9	66.4	65.0	65.7
Result				P	P	P	P

**Legend:** P: Positive, breaker cleared or breaker closed and cleared N: Negative, breaker failed

**Remarks:**

PEHLA 0231Ra / 01: Current calibration  
 PEHLA 0231Ra / 02: No-load operation  
 PEHLA 0231Ra / 03: Voltage calibration  
 PEHLA 0231Ra / 04 and 05: Tests with reduced values  
 PEHLA 0231Ra / 06 to 08: The operating devices are supplied at their minimum voltage.

**Condition of test object after test:** Circuit-breaker without functional or visible change.



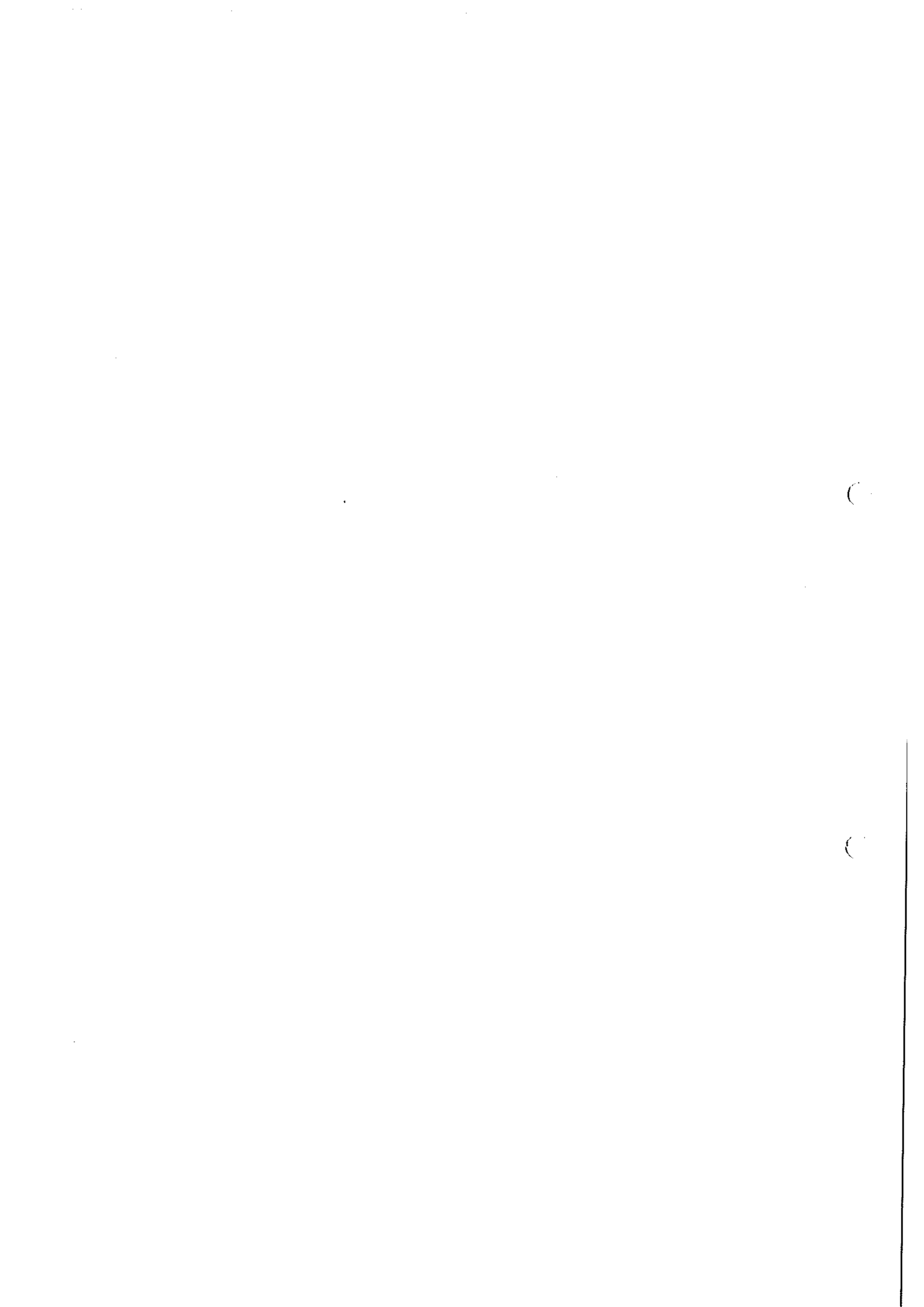

Test no.  
PEHLA 0231Ra / 06

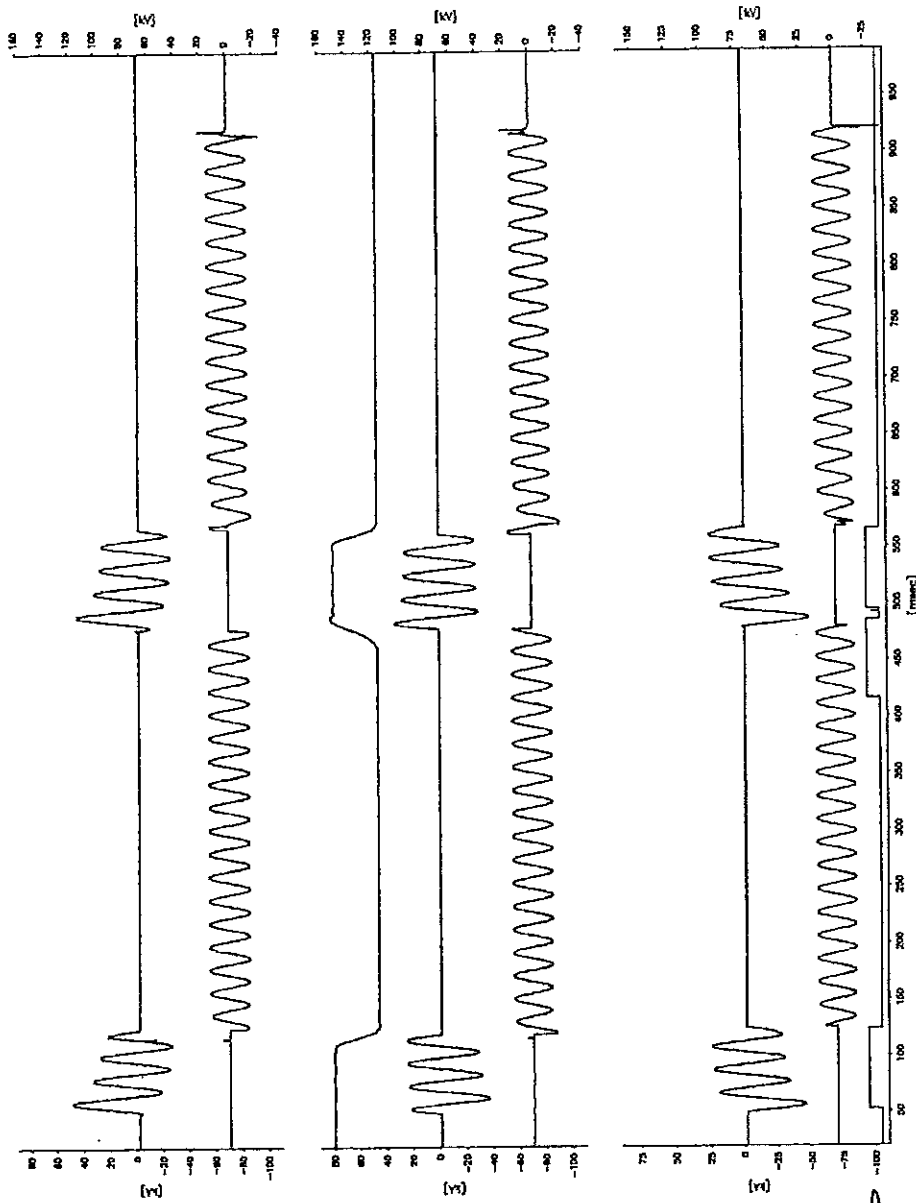

ВЯРНО С ОРИГИНАЛА



