

**ПРЕДЛОЖЕНИЕ  
ЗА ИЗПЪЛНЕНИЕ НА ПОРЪЧКАТА  
ЗА ОБОСОБЕНА ПОЗИЦИЯ 1**

**ДО: „ЧЕЗ РАЗПРЕДЕЛЕНИЕ БЪЛГАРИЯ” АД,**

ОТ: «Електролюкс Табаков и синове» ООД –гр. Пловдив  
Адрес: гр. Пловдив ул. «Седянка», №9  
тел.: 032/969-280 факс: 032/969-281; e-mail: info@electrolux-tabakov.com, ntelectrolux@abv.bg  
Единен идентификационен код: 115812097,  
Представявано от Георги Николов Табаков – Управител  
Лице за контакти: Георги Николов Табаков, тел.: 032/969-280 факс: 032/969-281; e-mail: info@electrolux-tabakov.com; ntelectrolux@abv.bg

**УВАЖАЕМИ ГОСПОЖИ И ГОСПОДА,**

След като се запознахме с изискванията на възложителя за изпълнение на обществена поръчка с реф. № PPD 17 – 052 и предмет: „Модернизация (ретрофит) на електрически уредби 110/20 (10) kV и въвеждането им в режим на телемеханика, аз долуподписаният Георги Николов Табаков, в качеството си на представител на «Електролюкс Табаков и синове» ООД, декларирам, че:

В случай че бъдем определени за изпълнител на обществената поръчка, декларираме, че:

1. Ще изпълняваме договора съгласно техническите изисквания на възложителя, представени в т. 4 "Обем от дейности и основни изисквания при изпълнението на ретрофита (модернизацията) на енергийните обекти по предмета на поръчката" от раздел I. на документацията за участие, включени като Приложение № 2 към договора за изпълнение на обществената поръчка.
2. Всички материали, апаратура, оборудване, съоръжения и резервни части, които ще доставим и ще влягаме при изпълнение на предмета на поръчката ще са нови, неупотребявани, придружени от декларации и/или сертификати/декларации за съответствие, съгласно изискванията на българското законодателство.
3. Задължаваме се при всяка доставка на материал и/или апаратура и/или оборудване и/или съоръжение и/или резервни части, същите да бъдат придружени от изискуемите документи съгласно договора.
4. Представяме изисканата информация в Техническо предложение за оборудване – Приложение 2 към настоящото Предложение за изпълнение на поръчката, като:
  - 4.1. Представям попълнено „Гарантирано предложение“ в таблиците с технически данни. Предлаганото от нас оборудване отговаря на минималните технически изисквания на Възложителя, които не съдържат графа „Гарантирано предложение“ в таблиците на техническите спецификации на стоката от раздел II. „Технически спецификации и изисквания на възложителя за изпълнение на поръчката“ от документацията за участие.
  - 4.2. Представям всички изисквани данни и документи от таблиците с Изисквания към документацията и изпитанията. Запознат съм с изискването, че представените документи трябва да бъдат на български език или с превод на български език, придружени с оригиналните документи, с изключение на каталозите и протоколи от изпитания /в случай, че се изискват/ за материалите, които могат да се представят и само на английски език.
5. Запознат съм, че представените от нас технически документи са доказателство за декларираните технически данни и параметри на предлаганото оборудване.
6. Заявяваме, че предлаганите от нас материали, апаратура, оборудване, съоръжения и резервни части са с технически характеристики покриващи посочените от възложителя в раздел II. „Технически спецификации и изисквания на възложителя за изпълнение на поръчката“ от документацията за участие.
7. Ще изпълняваме договора съгласно техническите изисквания на възложителя, представени в раздел II. «Технически спецификации и изисквания на възложителя за изпълнение на поръчката» от документацията за участие, които са включени като Приложение № 3 към договора за изпълнение на обществената поръчка.



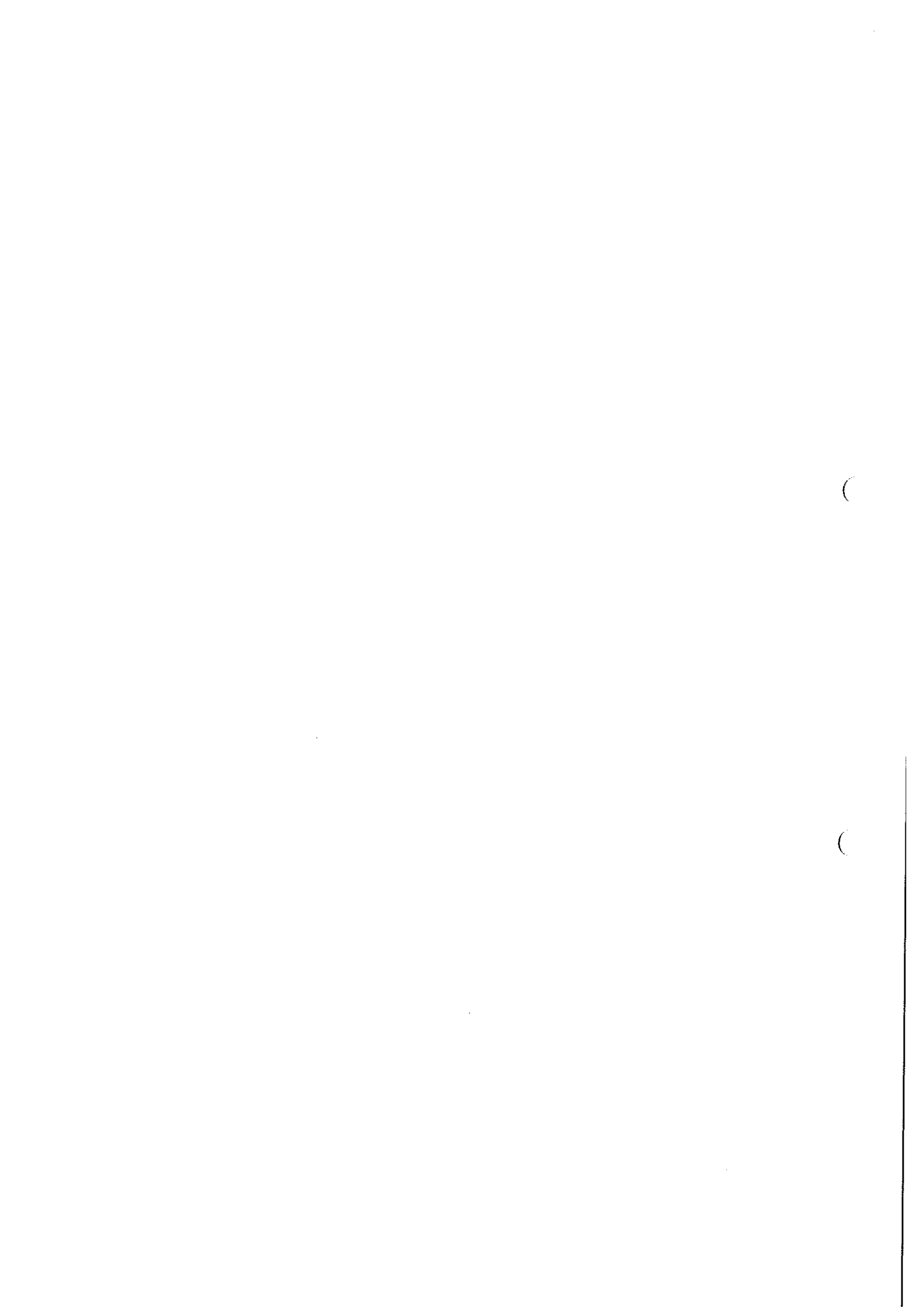

8. Потвърждаваме, че доставяните от нас материали, апаратура, оборудване и съоръжения ще отговарят на посочените от възложителя стандарти или на еквивалентни. В случай, че даден материал, апаратура, оборудване и съоръжение отговаря на стандарт, еквивалентен на посочения от Възложителя в раздел II. „Технически спецификации и изисквания на възложителя за изпълнение на поръчката“ от документацията за участие, се задължаваме да го отразим в отделен документ и да представим доказателства за еквивалентността на двата стандарта заедно с настоящото предложение за изпълнение на поръчката.

9. С настоящото гарантираме, че ще изпълним сроковете за изпълнение на поръчката, определени в Приложение 1 към настоящото Техническо предложение.

10. Гарантираме, че предложеното оборудване за Комуникация на цифрови защити /ЦЗ/ и контролер с RTU отговаря на посочените в Приложение 3 минимални технически изисквания на Възложителя.

11. Декларирам, че представител на участника, когото представлявам е извършил оглед на обекта, на който ще бъде извършен ретрофит и прилагам декларация за извършен оглед към настоящото предложение – Приложение № 4.

12. Предлагам гаранционни срокове:

12.1. за материалите, апаратурата, оборудването и съоръженията, гаранционните срокове са съгласно гаранционните срокове определени от съответния производител, но не по-малко от **36 месеца** от датата на приемно-предавателния протокол за приемане на оборудването;

12.2. за строителните работи гаранционните срокове съответстват на минималните гаранционни срокове, посочени в Наредба № 2 от 31 юли 2003 г. за въвеждане в експлоатация на строежите в Република България и минималните гаранционни срокове за изпълнени строителни и монтажни работи, съоръжения и строителни обекти.

13. Задължаваме се в рамките на гаранционните срокове всички разходи по отстраняване на дефекти или замяна на дефектни материали, апаратура, оборудване, съоръжения и резервни части с нови, да са за наша сметка.

14. Ще се съобразим с изискването на Възложителя и след сключване на договор ще изработим и представим линеен план-график за реализиране на модернизацията (ретрофита), в който за строителните или монтажни работи, планирани за извършване за след 29.12.2017 година, заскладяването на доставеното оборудване ще се извършва в складова база на Възложителя, на адрес: гр. София, ул. „Димитър Списаревски“ № 10 и ще бъде съобразено с изискванията на Приложение - „Условия за доставка и съхранение на материали, апаратура, оборудване и съоръжения, необходими за изпълнение на ретрофит“ от раздел II «Технически спецификации и изисквания на възложителя за изпълнение на поръчката» към документацията съответно представляващо приложение към договора, както и с условията, уговорени в договора. В случай, че доставките могат да бъдат извършени направо до обекта на изпълнение на поръчката и веднага да бъдат вложени в изпълнението на необходимите строителни и монтажни работи, в зависимост от графика, програмата и работния проект, е възможно същите да бъдат заявени за доставка, чрез възлагателен протокол от Възложителя, направо до обекта на изпълнение на поръчката.

**Неразделна част от настоящото предложение са следните приложения:**

- Приложение № 1 - Срокове за изпълнение на ретрофита;
- Приложение № 2 - Техническо предложение за оборудване;
- Приложение № 3 – Комуникация на цифрови устройства с RTU;
- Приложение № 4 – декларация за извършен оглед;
- Приложение № ... – други по преценка на участника;

Дата: 24.07.2017 г.

ПОДПИС и ПЕЧАТ:  
/Георги Табаков-Управител/



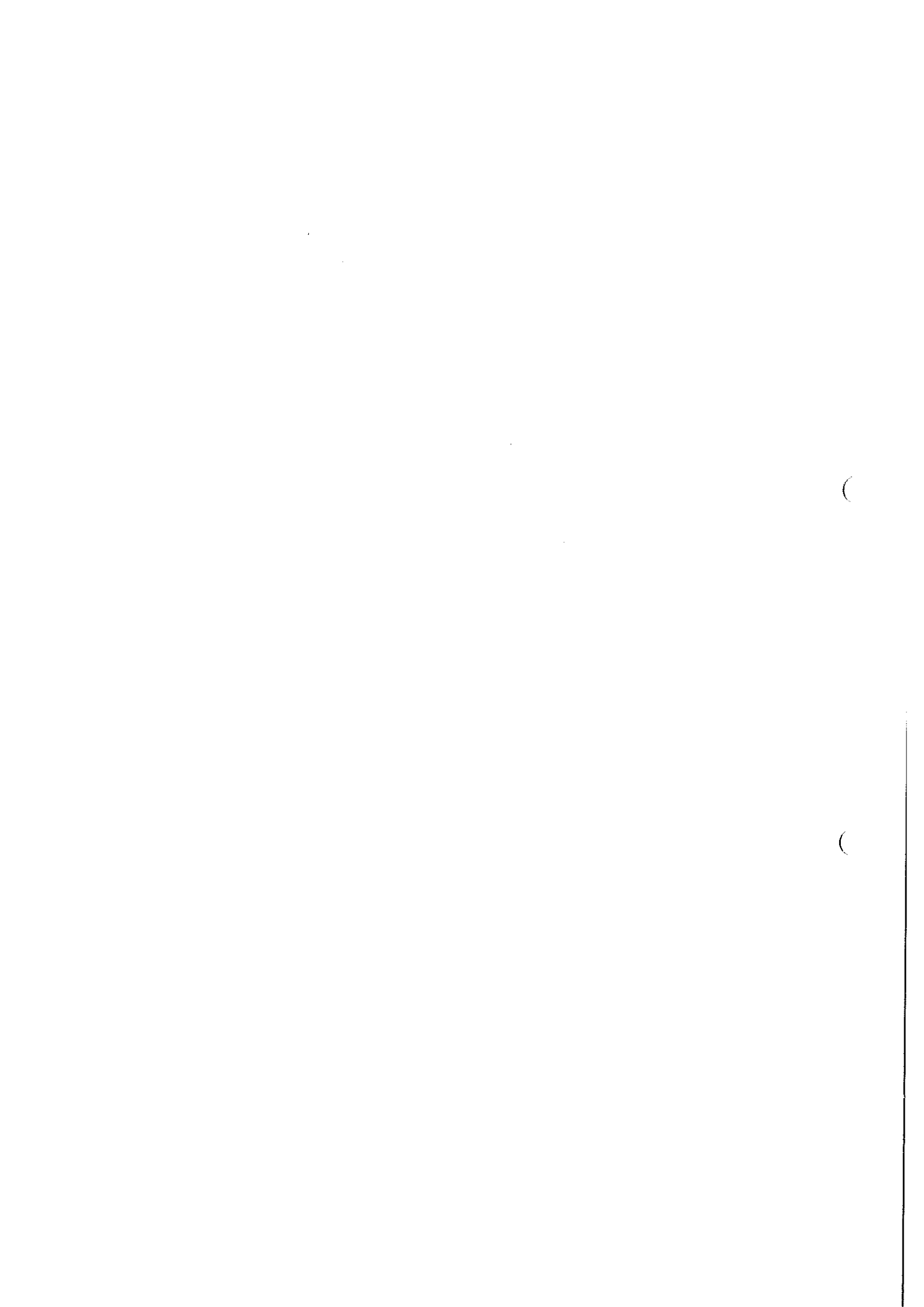



## ПРИЛОЖЕНИЕ 1

### СРОКОВЕ ЗА ИЗПЪЛНЕНИЕ НА РЕТРОФИТА ПО ОБОСОБЕНА ПОЗИЦИЯ № 1:

Проектирането, доставката на цялостното оборудване и изпълнението на всички необходими дейности за цялостната реализация на модернизацията (ретрофита) (като демонтаж на съществуващо оборудване, строителни работи /включително доставка на необходимите строителни материали/ по подготовка на площадките в енергийния обект за извършване на монтажа на новото оборудване, монтажни работи по отношение на доставеното ново енергийно оборудване, единични функционални проби на монтираните машини и съоръжения и въвеждането им в работен режим на телемеханика, както и провеждане на обучение на персонал на възложителя за работа с новото оборудване) и настоящото техническо задание следва да се изпълнят в срок до **18 (осемнадесет) месеца**, считано от датата на подписване на договора за изпълнение на поръчката.

#### **1. Срок за изготвяне на програмата с линейния план-график за цялостно изпълнение на модернизацията (ретрофита) и представянето ѝ на Възложителя:**

Срокът за изготвяне на програмата с линейния план-график и представянето ѝ на Възложителя за одобрение е до **14 (четиринадесет) дни**, считано от датата на подписване на договора. Срокът за одобрение на предложената програма с линеен план-график от Възложителя е до **3 (три) дни**, считано от датата на представяне на изработената програмата с линейния план-график на Възложителя.

#### **2. Изготвяне на работен проект:**

Срокът за проектирането на модернизацията (ретрофит) на ЗРУ 10 kV в пълен обем е до **20 (двадесет) дни** след датата на подписване на Договора с конкретния Изпълнител.

#### **3. Съгласуване на работния проект с „ЧЕЗ Разпределение България“ АД:**

Срокът за съгласуване на работния проект е до **10 (десет) дни** след датата на предаването му на Възложителя.

#### **4. Доставка на цялостно оборудване, съгласно утвърдения работен проект:**

Срокът за доставка на цялостното оборудване за изпълнение на предмета на поръчката съобразно предвижданията на съгласувания работен проект, както и на всички необходими резервни части, включително и за изработката и доставката на необходимите за модернизацията (ретрофита) врати и детайли в заводски условия, е до **100 (сто) дни** от датата на одобрена от Възложителя заявка до съответен доставчик, по количествено – стойностни сметки към договора. В допълнение, доставките на цялостното оборудване, апарати и помощни съоръжения, планирани в утвърдения линеен план-график за изпълнение на предмета на поръчката, в частта им предвидена за 2017 година (до 29.12.2017 г.), следва да се изпълняват планово направо до работната площадка (съответният енергиен обект, който се модернизира). За всички останали дейности за изпълнение на модернизацията (ретрофита) по предмета на поръчката, планирани за извършване през 2018 година (след 29.12.2017 г.), цялостното оборудване, апарати и помощни съоръжения, както и резервните части, включително изработените врати и детайли в заводски условия, следва да бъдат доставени до складова база на Възложителя, на адрес: гр. София, ул. „Димитър Списаревски“ № 10.

Доставеното оборудване в складовата база на Възложителя ще бъде предоставено за отговорно пазене на Възложителя, при спазване на съвкупност от условия, дейности и мероприятия за заскладяване/изземане от склад, описани в Приложение – „Условия за доставка и съхранение на материали, апаратура, оборудване и съоръжения, необходими за изпълнение на ретрофит“. Графикът за доставка на цялостното оборудване в складовата база на Възложителя е неразделна част от линейния план-график за изпълнение на модернизацията (ретрофита) на съответния енергиен обект. Цялостното оборудване, апарати и помощни съоръжения се предоставят за заскладяване в здрава заводска опаковка. През времето на престой същите няма да се разопаковат, използват или друго. Входящ съответно изходящ контрол по отношение на оборудването за изпълнение на поръчката, следва да се извърши от представители на Възложителя и Изпълнителя при заскладяване и при изземане на доставените материали и оборудване, на място в складовата база на Възложителя, както и при доставката на съответното оборудване на работната площадка, преди то да бъде монтирано.

#### **5. Срок за изпълнение на модернизацията (ретрофита) на ЗРУ 10 kV:**

**Изпълнението на модернизацията (ретрофита) на ЗРУ 10 kV**, включително и въвеждане на вериги за телемеханика, е до **150 (сто и петдесет) дни** от датата на първия подписан възлагателен протокол за изпълнение на ретрофит на присъединение 10 kV.

Срокът за изпълнение на дейности по изпълнение на модернизацията (ретрофита), като демонтаж на съществуващо оборудване, строителни работи /включително доставка на необходимите строителни материали/ по подготовка на площадките в енергийния обект за



(

(

извършване на монтажа на новото оборудване и монтажни работи по отношение на доставеното ново енергийно оборудване, единични функционални проби на монтираните машини и съоръжения и въвеждането им в работен режим на телемеханика е до 150 (сто и петдесет) дни, считано от датата на първия възлагателен протокол.

**6. Обучение на специалисти на Възложителя:**

- Срокът за изготвяне от страна на избрания Изпълнител на програма за обучение на 6-ма служители на Възложителя и предаването ѝ за одобрение на Възложителя е **до 10 (десет) дни**, считано от датата на съгласуване на работния проект от Възложителя и предаването му на Изпълнителя;
- Срокът за одобрение на програмата за обучение от страна на Възложителя е **до 10 (десет) дни**, след датата на предаването ѝ на Възложителя.
- Срокът за провеждане на обучението и сертифицирането на 6-ма служители на Възложителя, за работа и поддръжка на доставеното и монтирано оборудване, включително цифрови защиты и др. е **до 10 (десет) дни**, след датата на одобрение на програмата за обучение от страна на Възложителя.

**7. Изработване и предоставяне на ексекутивна документация:**

Срокът за изработване и предоставяне от Изпълнителя на Възложителя на ексекутивни чертежи (документация) с нанесени всички изменения в работния проект, настъпили в процеса на изпълнение на модернизацията (ретрофита), е **до 15 (петнадесет) работни дни**, считано от датата на последния подписан възлагателен протокол за изпълнение на модернизацията (ретрофита) на присъединения 10 kV, с който приключва целия обем дейности в обекта, но не по-късно от датата на провеждане на 72 часовите проби под напрежение и товар.

**8. Провеждане на 72-часови проби под напрежение и товар:**

Срокът за провеждане на 72-часови проби под напрежение и товар и въвеждане на новоизградената ЗРУ 10 kV и свързаните с нормалната ѝ експлоатация апарати и съоръжения в работен режим е **до 10 (десет) работни дни**, считано от датата на протокола на приемателната комисия за приемане на цялостното изпълнение на модернизацията (ретрофит) на ЗРУ 10 kV в пълен обем за целия обект.

Дата: 24.07.2017 г.

ПОДПИС И ПЕЧАТ:  
/Георги Табаков-Управител/



A handwritten signature in black ink, consisting of stylized, overlapping loops.

(

(

**ПРИЛОЖЕНИЕ 2**  
Техническо предложение за оборудване

**ТАБЛИЦА 1 ОБОСОБЕНА ПОЗИЦИЯ № 1**  
**СТАНДАРТ НА МАТЕРИАЛА ЗА ТРИПОЛЮСНИ ВАКУУМНИ ПРЕКЪСВАЧИ, 12 kV/31,5 kA ЗА**  
**МОНТИРАНЕ НА ЗАКРИТО, ФИКСИРАН**

Изисквания към документацията и изпитванията:

№	Документ при участие	Приложение № (или текст)
1.	Техническо описание на прекъсвача, в т.ч. гарантирани параметри и съоръжаване	Приложение 1.1 документ: Приложение 1.1 - Техническо описание.pdf помощен документ: CA_VD4-50kA(EN)V_1VCP000001_DigiPrint.pdf помощен документ: MA_VD4-36kV-50KA(EN)Y_647654-1403 .pdf
2.	Протоколи от типови изпитвания на английски или български език, проведени от независима акредитирана изпитателна лаборатория – заверени копия (и допълнителни изпитвания, ако са проведени), с приложен списък на отделните изпитвания на български език.	Приложение 1.2 Документи пакет1: 100081_C.pdf; 0003Ra.pdf; HZ144F08.pdf; HZ146L02.pdf; MZZS1A03.pdf; pehla0231Ra.pdf; pehla0316Ra.pdf; Превод на 100081_C List_of_type_tests_BG.pdf Документи пакет2: 0016Ra[1].pdf; 0020Ra[1].pdf; 100087_C.pdf; CesiMPA4_010735[1].pdf; HZ146L02.pdf; HZ147E10[1].pdf; pehla0303Ra.pdf; pehla0317_2Ra[1].pdf; Превод на 100087_C List_of_type_tests_BG.pdf
3.	Сертификат/акредитация на независимата изпитателна лаборатория, провела типовите изпитвания – заверено копие	Приложение 1.3 Документ: Приложение 1.3 - Акредитация.pdf

Технически данни за триполюсен вакуумен прекъсвач 12 kV, 1250 A, 31,5 kA, за монтиране на закрито, фиксиран, които се попълват от Участника в графа „Гарантирано предложение“:

Наименование на материала		Триполюсен вакуумен прекъсвач, 12 kV/1250 A/31,5 kA, за монтиране на закрито, фиксиран	
Съкратено наименование на материала		Трип. Вак. Прек. 12 kV/1250 A/31,5 kA, 3М, Ф	
№	Технически параметър	Изискване	Гарантирано предложение
1.	Тип/референтен номер съгласно каталога на производителя	Да се посочи	VD4 фиксиран 12 kV, 1250 A, 31,5 kA, p 210 mm; тип VD4 12.12.32 p210; Производствен номер: 1VCF337111R1352
2.	Производител	Да се посочи	АББ Италия, гр. Далмине – Бергамо, Завод АББ Унита оператива САЧЕ
3.	Обявен нормален ток, I <sub>n</sub>	≥ 1250 A	1250

Технически данни за триполюсен вакуумен прекъсвач 12 kV, 2500 A, 31,5 kA, за монтиране на закрито, фиксиран, които се попълват от Участника в графа „Гарантирано предложение“:



Наименование на материала		Триполюсен вакуумен прекъсвач, 12 kV/2500 A/31,5 kA, за монтиране на закрито, фиксиран	
Съкратено наименование на материала		Трип. Вак. Прек., 12 kV/2500 A/31,5 kA, 3М, Ф	
№	Технически параметър	Изискване	Гарантирано предложение
1.	Тип/референтен номер каталога на производителя	Да се посочи	VD4 фиксиран 12 kV, 2500 A, 31,5 kA, р 210 mm; Тип VD4 12.25.32 р210; Производствен номер: 1VCF337111R0652
2.	Производител	Да се посочи	АББ Италия, гр. Далмине – Бергамо, Завод АББ Унита оператива САЧЕ
3.	Обявен нормален ток, I <sub>r</sub>	≥ 2500 A	2500

ТАБЛИЦА № 2 КЪМ ОБОСОБЕНА ПОЗИЦИЯ № 1  
СТАНДАРТ НА МАТЕРИАЛА ЗА ТОКОВИ ТРАНСФОРМАТОРИ 10 kV ЗА МОНТИРАНЕ НА  
ЗАКРИТО, ФИКСИРАН

Изисквания към документацията и изпитванията:

№	Документ за участие	Приложение № (или текст)
1.	Точно обозначение на типа на токовите измервателни трансформатори, производителя и страната на произход и последно издание на каталога на производителя	Токови измервателни трансформатори тип TPU 4x.xx Производител: АБВ s.r.o. Произход: Чехия Последно издание на каталога е дадено в Приложение 2.1
2.	Удостоверение за одобряване на типа на токовите измервателни трансформатори, издадено по реда и при условията на Закона за измерванията	Приложение 2.2
3.	Протоколи от типови изпитвания на токовите измервателни трансформатори на английски или български език, проведени от независима изпитателна лаборатория с приложени резултати от изпитванията, представени при доставка	Приложение 2.3
4.	Сертификат/акредитация на независимата изпитателна лаборатория, провела типовите изпитвания – заверено копие	Приложение 2.4

Технически параметри на токови измервателни трансформатори 10 kV, 2500/5/5 А, подпорен тип, за монтиране на закрито, които се попълват от Участника в графа „Гарантирано предложение“:

Наименование на материала		Токов измервателен трансформатор 10 kV, 2500/5/5 А за монтиране на закрито	
Съкратено наименование на материала		ТИТ 10 kV, 2500/5/5 А, 3М	
№	Параметър	Изискване	Гарантирано предложение
1.	Тип/референтен номер съгласно каталога на производителя	Да се посочи	TPU 46.33

2.	Производител	Да се посочи	ABB S.r.o, Република Чехия
----	--------------	--------------	-------------------------------

Технически параметри на токови измервателни трансформатори 10 kV, 400/5/5 A, подпорен тип, за монтиране на закрито, които се попълват от Участника в графа „Гарантирано предложение“:

Наименование на материала		Токов измервателен трансформатор 10 kV, 400/5/5 A за монтиране на закрито	
Съкратено наименование на материала		ТИТ 10 kV, 400/5/5 A, 3М	
№	Параметър	Изискване	Гарантирано предложение
1.	Тип/референтен номер съгласно каталога на производителя	Да се посочи	TPU 40.23
2.	Производител	Да се посочи	ABB S.r.o, Република Чехия

**ТАБЛИЦА № 3 КЪМ ОБОСОБЕНА ПОЗИЦИЯ № 1  
СТАНДАРТ НА МАТЕРИАЛА ЗА НАПРЕЖЕНОВИ ТРАНСФОРМАТОРИ 10 kV ЗА МОНТИРАНЕ  
НА ЗАКРИТО, ФИКСИРАН**

Изисквания към документацията и изпитванията:

№	Документ за участие	Приложение № (или текст)
1.	Точно обозначение на типа на напреженовия трансформатор (НИТ), производителя и страна на произход и последно издание на каталога на производителя	Напреженови измервателни трансформатори тип ТЈС 4 Производител: АВВ s.r.o. Произход: Чехия Последно издание на каталога е дадено в Приложение 3.1
2.	Удостоверение за одобряване на типа на НИТ, издадено по реда и при условията на Закона за измерванията	Приложение 3.2
3.	Протоколи от типови изпитвания на токовите измервателни трансформатори на английски или български език, проведени от независима изпитателна лаборатория с приложени резултати от изпитванията, представени при доставка	Приложение 3.3
4.	Сертификат/акредитация на независимата изпитателна лаборатория, провела типовите изпитвания – заверено копие	Приложение 3.4

Технически параметри на напреженови измервателни трансформатори 10 kV, подпорен тип, за монтиране на закрито, които се попълват от Участника в графа „Гарантирано предложение“:

*[Handwritten signature]*



<b>Наименование на материала</b>		Напрежен измервателен трансформатор 10 kV, еднополюсен, с две вторични намотки, за монтиране на закрито	
<b>Съкратено наименование на материала</b>		НИТ 10 kV, 1P, с две вторични намотки, 3М	
<b>№</b>	<b>Параметър</b>	<b>Изискване</b>	<b>Гарантирано предложение</b>
1.	Тип/референтен номер съгласно каталога на производителя	Да се посочи	TJC 4
2.	Производител	Да се посочи	ABB S.r.o, Република Чехия

**ТАБЛИЦА 4 КЪМ ОБОСОБЕНА ПОЗИЦИЯ № 1  
СТАНДАРТ НА МАТЕРИАЛА ЗА ЦИФРОВИ ЗАЩИТИ ЗА ВЪЗДУШНИ И КАБЕЛНИ  
ЕЛЕКТРОПРОВОДНИ ЛИНИИ СР.Н.**

Технически данни за непосочна цифрова защита за въздушни и кабелни електропроводни линии Ср.Н., които се попълват от Участника в графа „Гарантирано предложение“:

<b>Название на материала</b>		Непосочна цифрова защита за въздушни и кабелни електропроводни линии СрН	
<b>Съкратено название на материала</b>		Непосочна ЦЗ ВКЕЛ СрН	
<b>№</b>	<b>Технически параметър</b>	<b>Изискване</b>	<b>Гарантирано предложение</b>
1.	Тип	Да се посочи	REF615
2.	Производител	Да се посочи	ABB Оу, Финландия

Дата: 24.07.2017 г.

**ПОДПИС И ПЕЧАТ:**  
/Георги Табаков-Управител/

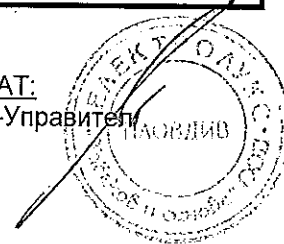

*(Handwritten signature)*



**ПРИЛОЖЕНИЕ 2**  
Техническо предложение за оборудване

**ТАБЛИЦА 1 ОБОСОБЕНА ПОЗИЦИЯ № 1**  
**СТАНДАРТ НА МАТЕРИАЛА ЗА ТРИПОЛЮСНИ ВАКУУМНИ ПРЕКЪСВАЧИ, 12 kV/31,5 kA ЗА**  
**МОНТИРАНЕ НА ЗАКРИТО, ФИКСИРАН**

Изисквания към документацията и изпитванията:

№	Документ при участие	Приложение № (или текст)
1.	Техническо описание на прекъсвача, в т.ч. гарантирани параметри и съоръжаване	Приложение 1.1 документ: Приложение 1.1 - Техническо описание.pdf помощен документ: CA_VD4-50kA(EN)V_1VCP000001_DigiPrint.pdf помощен документ: MA_VD4-36kV-50KA(EN)Y_647654-1403 .pdf
2.	Протоколи от типови изпитвания на английски или български език, проведени от независима акредитирана изпитателна лаборатория – заверени копия (и допълнителни изпитвания, ако са проведени), с приложен списък на отделните изпитвания на български език.	Приложение 1.2 Документи пакет1: 100081_C.pdf; 0003Ra.pdf; HZ144F08.pdf; HZ146L02.pdf; MZZS1A03.pdf; pehla0231Ra.pdf; pehla0316Ra.pdf; Превод на 100081_C List_of_type_tests_BG.pdf Документи пакет2: 0016Ra[1].pdf; 0020Ra[1].pdf; 100087_C.pdf; CesiMPA4_010735[1].pdf; HZ146L02.pdf; HZ147E10[1].pdf; pehla0303Ra.pdf; pehla0317_2Ra[1].pdf; Превод на 100087_C List_of_type_tests_BG.pdf
3.	Сертификат/акредитация на независимата изпитателна лаборатория, провела типовите изпитвания – заверено копие	Приложение 1.3 Документ: Приложение 1.3 - Акредитация.pdf

Технически данни за триполюсен вакуумен прекъсвач 12 kV, 1250 A, 31,5 kA, за монтиране на закрито, фиксиран, които се попълват от Участника в графа „Гарантирано предложение“:

Наименование на материала		Триполюсен вакуумен прекъсвач, 12 kV/1250 A/31,5 kA, за монтиране на закрито, фиксиран	
Съкратено наименование на материала		Трип. Вак. Прек., 12 kV/1250 A/31,5 kA, 3М, Ф	
№	Технически параметър	Изискване	Гарантирано предложение
1.	Тип/референтен номер съгласно каталога на производителя	Да се посочи	VD4 фиксиран 12 kV, 1250 A, 31,5 kA, p 210 mm; тип VD4 12.12.32 p210; Производствен номер: 1VCF337111R1352
2.	Производител	Да се посочи	АББ Италия, гр. Далмине – Бергамо, Завод АББ Унита оператива САЧЕ
3.	Обявен нормален ток, I <sub>r</sub>	≥ 1250 A	1250

Технически данни за триполюсен вакуумен прекъсвач 12 kV, 2500 A, 31,5 kA, за монтиране на закрито, фиксиран, които се попълват от Участника в графа „Гарантирано предложение“:



Наименование на материала		Триполюсен вакуумен прекъсвач, 12 kV/2500 A/31,5 kA, за монтиране на закрито, фиксиран	
Съкратено наименование на материала		Трип. Вак. Прек., 12 kV/2500 A/31,5 kA, 3М, Ф	
№	Технически параметър	Изискване	Гарантирано предложение
1.	Тип/референтен номер съгласно каталога на производителя	Да се посочи	VD4 фиксиран 12 kV, 2500 A, 31,5 kA, р 210 mm; Тип VD4 12.25.32 р210; Производствен номер: 1VCF337111R0652
2.	Производител	Да се посочи	АББ Италия, гр. Далмине – Бергамо, Завод АББ Унита оператива САЧЕ
3.	Обявен нормален ток, I <sub>r</sub>	≥ 2500 A	2500

ТАБЛИЦА № 2 КЪМ ОБОСОБЕНА ПОЗИЦИЯ № 1  
СТАНДАРТ НА МАТЕРИАЛА ЗА ТОКОВИ ТРАНСФОРМАТОРИ 10 kV ЗА МОНТИРАНЕ НА  
ЗАКРИТО, ФИКСИРАН

Изисквания към документацията и изпитванията:

№	Документ за участие	Приложение № (или текст)
1.	Точно обозначение на типа на токовите измервателни трансформатори, производителя и страната на произход и последно издание на каталога на производителя	Токови измервателни трансформатори тип TPU 4x.xx Производител: АBB s.r.o. Произход: Чехия Последно издание на каталога е дадено в Приложение 2.1
2.	Удостоверение за одобряване на типа на токовите измервателни трансформатори, издадено по реда и при условията на Закона за измерванията	Приложение 2.2
3.	Протоколи от типови изпитвания на токовите измервателни трансформатори на английски или български език, проведени от независима изпитателна лаборатория с приложени резултати от изпитванията, представени при доставка	Приложение 2.3
4.	Сертификат/акредитация на независимата изпитателна лаборатория, провела типовите изпитвания – заверено копие	Приложение 2.4

Технически параметри на токови измервателни трансформатори 10 kV, 2500/5/5 A, подпорен тип, за монтиране на закрито, които се попълват от Участника в графа „Гарантирано предложение“:

Наименование на материала		Токов измервателен трансформатор 10 kV, 2500/5/5 A за монтиране на закрито	
Съкратено наименование на материала		ТИТ 10 kV, 2500/5/5 A, 3М	
№	Параметър	Изискване	Гарантирано предложение
1.	Тип/референтен номер съгласно каталога на производителя	Да се посочи	TPU 46.33

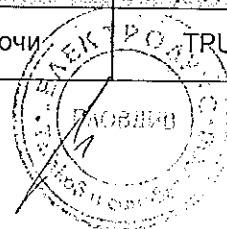

2.	Производител	Да се посочи	ABB S.r.o, Република Чехия
----	--------------	--------------	-------------------------------

Технически параметри на токови измервателни трансформатори 10 kV, 400/5/5 A, подпорен тип, за монтиране на закрито, които се попълват от Участника в графа „Гарантирано предложение“:

Наименование на материала		Токов измервателен трансформатор 10 kV, 400/5/5 A за монтиране на закрито	
Съкратено наименование на материала		ТИТ 10 kV, 400/5/5 A, 3М	
№	Параметър	Изискване	Гарантирано предложение
1.	Тип/референтен номер съгласно каталога на производителя	Да се посочи	TPU 40.23
2.	Производител	Да се посочи	ABB S.r.o, Република Чехия

**ТАБЛИЦА № 3 КЪМ ОБОСОБЕНА ПОЗИЦИЯ № 1  
СТАНДАРТ НА МАТЕРИАЛА ЗА НАПРЕЖЕНОВИ ТРАНСФОРМАТОРИ 10 kV ЗА МОНТИРАНЕ  
НА ЗАКРИТО, ФИКСИРАН**

Изисквания към документацията и изпитванията:

№	Документ за участие	Приложение № (или текст)
1.	Точно обозначение на типа на напреженовия трансформатор (НИТ), производителя и страна на произход и последно издание на каталога на производителя	Напреженови измервателни трансформатори тип ТЈС 4 Производител: АВВ s.r.o. Произход: Чехия Последно издание на каталога е дадено в Приложение 3.1
2.	Удостоверение за одобряване на типа на НИТ, издадено по реда и при условията на Закона за измерванията	Приложение 3.2
3.	Протоколи от типови изпитвания на токовите измервателни трансформатори на английски или български език, проведени от независима изпитателна лаборатория с приложени резултати от изпитванията, представени при доставка	Приложение 3.3
4.	Сертификат/акредитация на независимата изпитателна лаборатория, провела типовите изпитвания – заверено копие	Приложение 3.4

Технически параметри на напреженови измервателни трансформатори 10 kV, подпорен тип, за монтиране на закрито, които се попълват от Участника в графа „Гарантирано предложение“:



Наименование на материала		Напреженов измервателен трансформатор 10 kV, еднополюсен, с две вторични намотки, за монтиране на закрито	
Съкратено наименование на материала		НИТ 10 kV, 1P, с две вторични намотки, ЗМ	
№	Параметър	Изискване	Гарантирано предложение
1.	Тип/референтен номер съгласно каталога на производителя	Да се посочи	TJC 4
2.	Производител	Да се посочи	ABB S.r.o, Република Чехия

ТАБЛИЦА 4 КЪМ ОБОСОБЕНА ПОЗИЦИЯ № 1  
СТАНДАРТ НА МАТЕРИАЛА ЗА ЦИФРОВИ ЗАЩИТИ ЗА ВЪЗДУШНИ И КАБЕЛНИ  
ЕЛЕКТРОПРОВОДНИ ЛИНИИ СР.Н.

Технически данни за непосочна цифрова защита за въздушни и кабелни електропроводни линии Ср.Н., които се попълват от Участника в графа „Гарантирано предложение“:

Название на материала		Непосочна цифрова защита за въздушни и кабелни електропроводни линии СрН	
Съкратено название на материала		Непосочна ЦЗ ВКЕЛ СрН	
№	Технически параметър	Изискване	Гарантирано предложение
1.	Тип	Да се посочи	REF615
2.	Производител	Да се посочи	ABB Оу, Финландия

Дата: 24.07.2017 г.

ПОДПИС и ПЕЧАТ:  
Георги Табаков-Управител

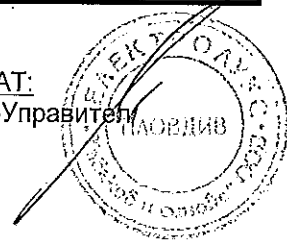

*(Handwritten signature)*

**ПРИЛОЖЕНИЕ 3**

**ТАБЛИЦА 5 КЪМ ОБОСОБЕНА ПОЗИЦИЯ № 1  
КОМУНИКАЦИЯ НА ЦИФРОВИ УСТРОЙСТВА С RTU**

Предложеното оборудване отговаря на посочените по-долу минималните технически изисквания на Възложителя:

№	Параметър/характеристика	Минимални технически изисквания
1.	Всяка защита и контролер да притежава стандартен интерфейс за комуникация по Ethernet, RS-485 или оптичен интерфейс, стандартен интерфейс за комуникация с персонален компютър и съответно програмно осигуряване.	Да
2. -	Комуникацията между RTU и ЦЗ, чрез оптичен интерфейс се осъществява с HFBR-4516Z connector .	Да
3. -	Комуникацията между RTU и ЦЗ, чрез четирипроводна или двупроводна мрежа RS-485 се осъществява с RJ-45.	Да
4. -	Комуникацията между ЦЗ и персонален компютър се осъществява с USB порт.	Да
5. -	Комуникационния интерфейс за връзка с RTU да се счита като неразделна част от ЦЗ. Комуникационния интерфейс да има светодиодна индикация за режима на работа.	Да
6.	ЦЗ трябва да включва система за самоконтрол и самодиагностика, на комуникациите с вътрешни и външни потребители.	Да
7.	Наличие на сменяема парола за достъп до данните за настройките на комуникационните функции.	Да
8.	Наличие на стандартен интерфейс и протокол съгласно MODBUS TCP/IP и IEC 61850 по жична връзка с локална мрежа за предаване на информацията .	Да
9.	Потребителска настройка на комуникацията по комуникационен протокол:	-
10. -	При осъществяване на комуникацията по комуникационен протокол съгласно БДС EN 61850-5	Потребителска настройка на IP адрес на ЦУ (ЦЗ и контролер)
11. -	При осъществяване на комуникацията по комуникационен протокол съгласно MODBUS TCP/IP.	Потребителска настройка на MODBUS server адрес на ЦУ (ЦЗ и контролер)

Дата: 24.07.2017 г.

**ПОДПИС и ПЕЧАТ:**

/Георги Табаков-Управител/

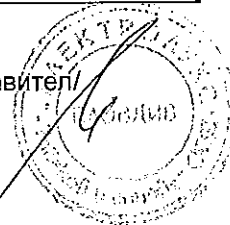

*(Handwritten signature)*

# Приложение 1.1 - Техническо описание

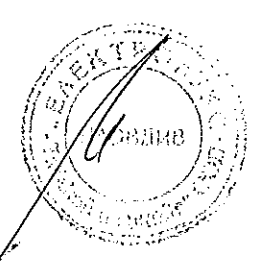

# VD4

Вакуумни прекъсвачи с U<sub>н</sub> средно натоваренно

12 ... 36kV – 630 ... 4000 A – 16 ... 50 kA

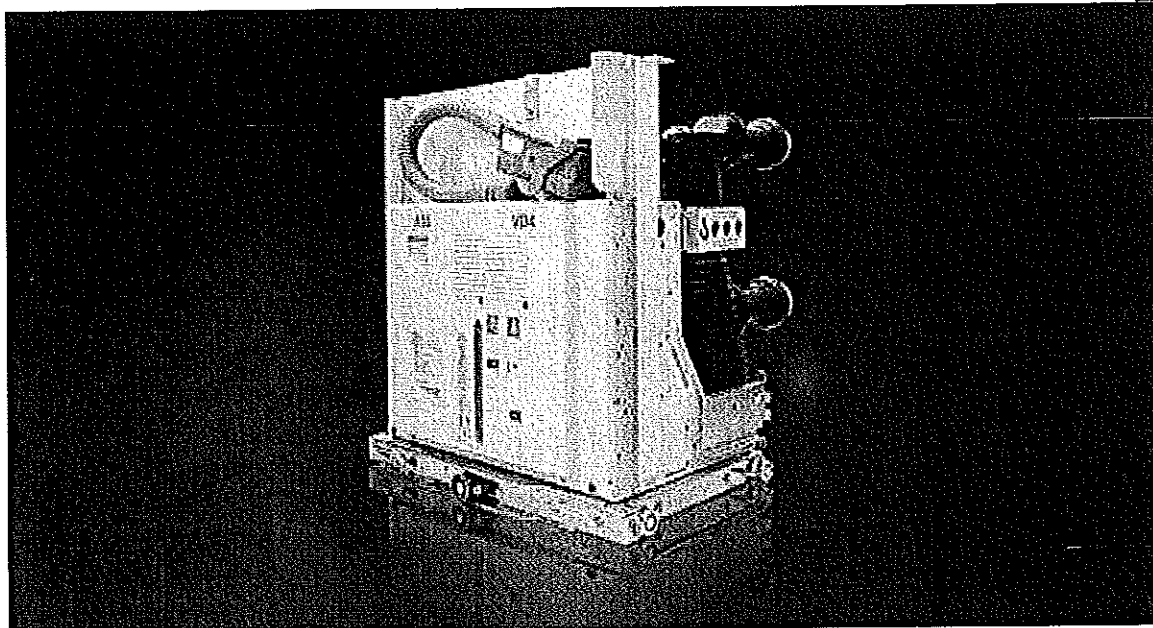

# ABB







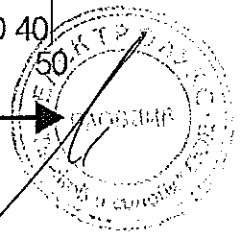
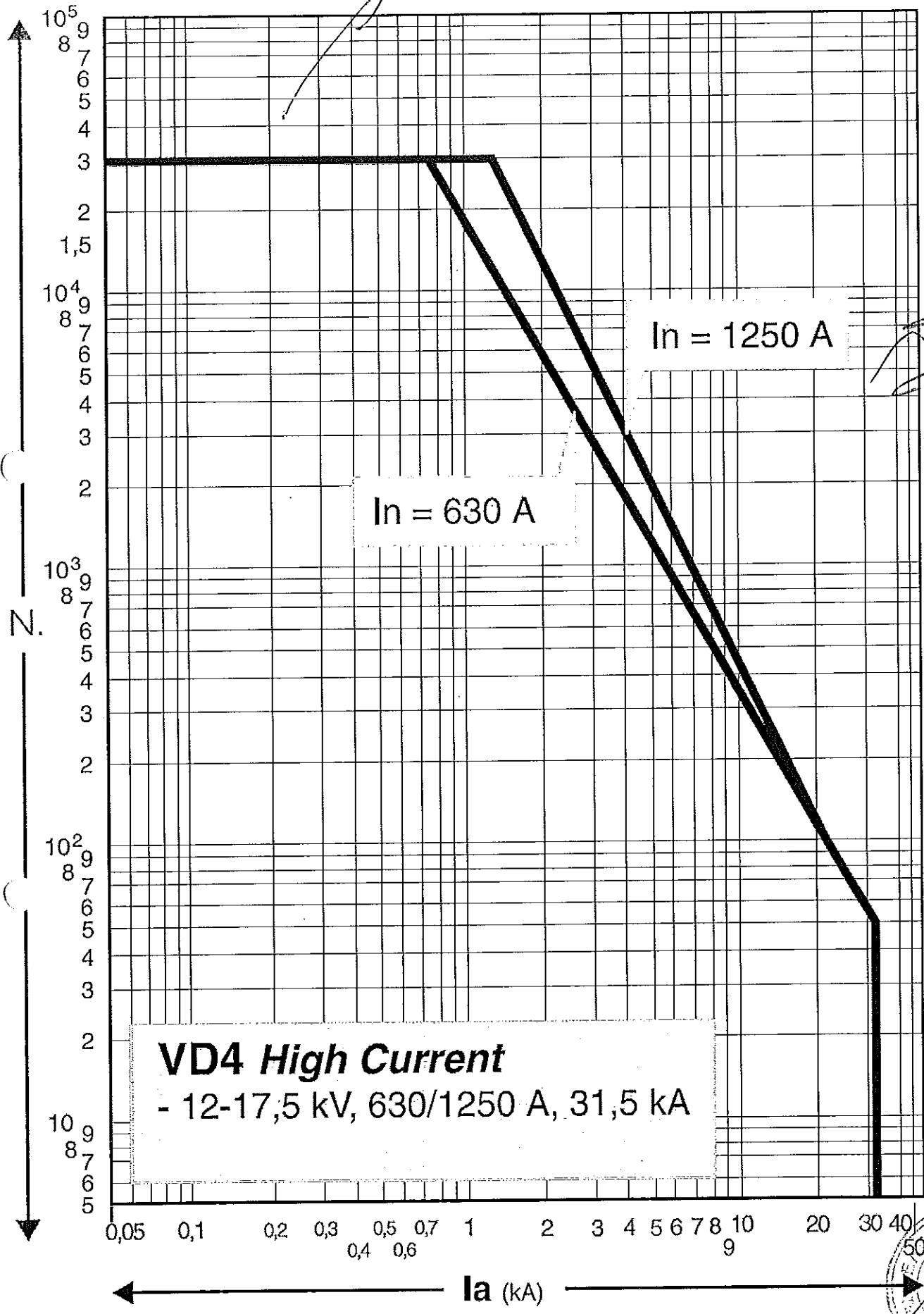

# Fixed VD4 circuit-breaker (12 kV) (\*)

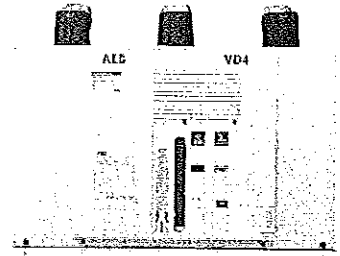

Circuit-breaker	VD4 12										
Standards	IEC 62271-100 *										
Rated voltage	Ur [kV]	12 (†)									
Rated insulation voltage	Us [kV]	12									
Withstand voltage at 50 Hz	Ud (1 min) [kV]	28									
Impulse withstand voltage	Up [kV]	75									
Rated frequency	fr [Hz]	50-60									
Rated normal current (40 °C)	Ir [A]	630	630	630	1250	1250	1250	1250	1250	1250	1250
		16	16	16	16	16	16	—	—	—	—
Rated breaking capacity (rated short-circuit breaking current symmetrical)	Isc [kA]	20	20	20	20	20	20	—	—	—	—
		25	25	25	25	25	25	—	—	—	—
		31.5	31.5	31.5	31.5	31.5	31.5	—	—	—	—
		—	—	—	—	—	—	40	40	—	—
		—	—	—	—	—	—	—	—	50	50
Rated short-time withstand current (3s)	Ik [kA]	16	16	16	16	16	16	—	—	—	—
		20	20	20	20	20	20	—	—	—	—
		25	25	25	25	25	25	—	—	—	—
		31.5	31.5	31.5	31.5	31.5	31.5	—	—	—	—
		—	—	—	—	—	—	40	40	—	—
Making capacity	Ip [kA]	—	—	—	—	—	—	—	50	50	—
		40	40	40	40	40	40	—	—	—	—
		50	50	50	50	50	50	—	—	—	—
		63	63	63	63	63	63	—	—	—	—
		80	80	80	80	80	80	—	—	—	—
Operation sequence	[O - 0.3 s - CO - 15 s - CO]	•	•	•	•	•	•	•	•	•	
Opening time	[ms]	33 ... 60									
Arcing time	[ms]	10 ... 15									
Total breaking time	[ms]	43 ... 75									
Closing time	[ms]	30 ... 60									
Maximum overall dimensions	H [mm]	461	461	461	461	461	461	589	589	610	610
	W [mm]	450	570	700	450	570	700	570	700	600	750
	D [mm]	424	424	424	424	424	424	424	424	459	459
	Pole distance P [mm]	150	210	275	150	210	275	210	275	210	275
Weight	[kg]	73	75	79	73	75	79	84	84	146	158
Standardised table of dimensions	TN	7405(†)	7406(†)	—	7405(†)	7406(†)	—	—	—	—	—
	1VCD	—	—	000051(†)	—	—	000051(†)	003282(†)	003285(†)	003440	003441
Operating temperature	[°C]	- 5 ... + 40									
Tropicalization	IEC: 60068-2-30, 60721-2-1	•									
Electromagnetic compatibility	IEC: 62271-1	•									

- (1) Poles in polyamide
- (2) Available in 10 kV voltage version in accordance with GOST standards
- (3) Up to 4000 A with forced ventilation
- (4) On request, the closing spring can be loaded by means of a removable crank handle outside operating mechanism (instead of linear loading by a lever built into the front of operating mechanism)

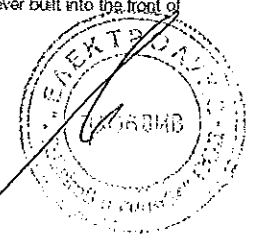

•															
12 (?)															
12															
28															
75															
50-60															
1600	1600	1600	1600	1600	1600	1600	2000	2000	2000	2000	2500	2500	2500	3150 (?)	3150 (?)
-	-	-	-	-	-	-	-	-	-	-	-	-	-	-	-
20	20	20	-	-	-	-	20	20	-	-	20	20	-	20	-
-	25	25	-	-	-	-	25	25	-	-	25	25	-	25	-
5	31.5	31.5	-	-	-	-	31.5	31.5	-	-	31.5	31.5	-	31.5	-
-	-	-	40	40	-	-	40	40	-	-	40	40	-	40	-
-	-	-	-	-	50	50	-	-	50	50	-	-	50	-	50
-	-	-	-	-	-	-	-	-	-	-	-	-	-	-	-
20	20	20	-	-	-	-	20	20	-	-	20	20	-	20	-
25	25	25	-	-	-	-	25	25	-	-	25	25	-	25	-
31.5	31.5	31.5	-	-	-	-	31.5	31.5	-	-	31.5	31.5	-	31.5	-
-	-	-	40	40	-	-	40	40	-	-	40	40	-	40	-
-	-	-	-	-	50	50	-	-	50	50	-	-	50	-	50
-	-	-	-	-	-	-	-	-	-	-	-	-	-	-	-
50	50	50	-	-	-	-	50	50	-	-	50	50	-	50	-
63	63	63	-	-	-	-	63	63	-	-	63	63	-	63	-
80	80	80	-	-	-	-	80	80	-	-	80	80	-	80	-
-	-	-	100	100	-	-	100	100	-	-	100	100	-	100	-
-	-	-	-	-	125	125	-	-	125	125	-	-	125	-	125
•	•	•	•	•	•	•	•	•	•	•	•	•	•	•	•
33 ... 60															
10 ... 15															
43 ... 75															
... 60															
599	599	599	599	589	610	610	599	599	610	610	599	599	610	635	636
450	570	700	570	700	600	750	570	700	600	750	570	700	750	700	750
424	424	424	424	424	459	459	424	424	459	459	424	424	459	424	459
150	210	275	210	275	210	275	210	275	210	275	210	275	275	275	275
93	98	105	84	84	146	158	98	105	146	158	98	105	163	140	177
-	7407 (?)	7408 (?)	-	-	-	-	7407 (?)	7408 (?)	-	-	7407 (?)	7408 (?)	-	-	-
000050	-	-	003282(?)	003285(?)	003440	003441	-	-	003440	003441	-	-	003441	000149 (?)	003443
- 5 ... + 40															
•															
•															



VD4 fixed circuit-breaker without bottom and top terminals (12 kV)

Ur	Isc	Rated uninterrupted current (40°C) [A]										Circuit-breaker type	
		H=461			H=589		H=599			H=610			H=636
kV	kA	D=424			D=424		D=424			D=459		D=459	
		u/l=205			u/l=310		u/l=310			u/l=310		u/l=310	
		I/g=217.5			I/g=238		I/g=237.5			I/g=237		I/g=237	
		P=150	P=210	P=275	P=210	P=275	P=150	P=210	P=275	P=210	P=275	P=275	
		W=450	W=570	W=700	W=570	W=700	W=450	W=570	W=700	W=600	W=750	W=750	
12	16	630											VD4 12.06.16 p150
	20	630											VD4 12.06.20 p150
	25	630											VD4 12.06.25 p150
	31.5	630											VD4 12.06.32 p150
	16	1250											VD4 12.12.16 p150
	20	1250											VD4 12.12.20 p150
	25	1250											VD4 12.12.25 p150
	31.5	1250											VD4 12.12.32 p150
	20							1600					VD4 12.16.20 p150
	25							1600					VD4 12.16.25 p150
	31.5							1600					VD4 12.16.32 p150
	16		630										VD4 12.06.16 p210
	20		630										VD4 12.06.20 p210
	25		630										VD4 12.06.25 p210
	31.5		630										VD4 12.06.32 p210
	16		1250										VD4 12.12.16 p210
	20		1250										VD4 12.12.20 p210
	25		1250										VD4 12.12.25 p210
	31.5		1250										VD4 12.12.32 p210
	40				1250								VD4 12.12.40 p210
	50									1250			VD4 12.12.50 p210
	20							1600					VD4 12.16.20 p210
	25							1600					VD4 12.16.25 p210
	31.5							1600					VD4 12.16.32 p210
	40				1600								VD4 12.16.40 p210
	50									1600			VD4 12.16.50 p210
	20							2000					VD4 12.20.20 p210
	25							2000					VD4 12.20.25 p210
	31.5							2000					VD4 12.20.32 p210
	40							2000					VD4 12.20.40 p210
	50									2000			VD4 12.20.50 p210
20							2500					VD4 12.25.20 p210	
25							2500					VD4 12.25.25 p210	
31.5							2500					VD4 12.25.32 p210	
16			630									VD4 12.06.16 p275	
20			630									VD4 12.06.20 p275	
25			630									VD4 12.06.25 p275	
31.5			630									VD4 12.06.32 p275	
16			1250									VD4 12.12.16 p275	
20			1250									VD4 12.12.20 p275	
25			1250									VD4 12.12.25 p275	
31.5			1250									VD4 12.12.32 p275	
40				1250								VD4 12.12.40 p275	
50									1250			VD4 12.12.50 p275	

- H = Height of the circuit-breaker.
- W = Width of the circuit-breaker.
- D = Depth of the circuit-breaker.
- u/l = Distance between bottom and top terminal.
- I/g = Distance between the bottom terminal and the resting surface of the circuit-breaker.
- P = Pole horizontal centre distance.

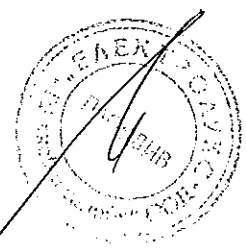



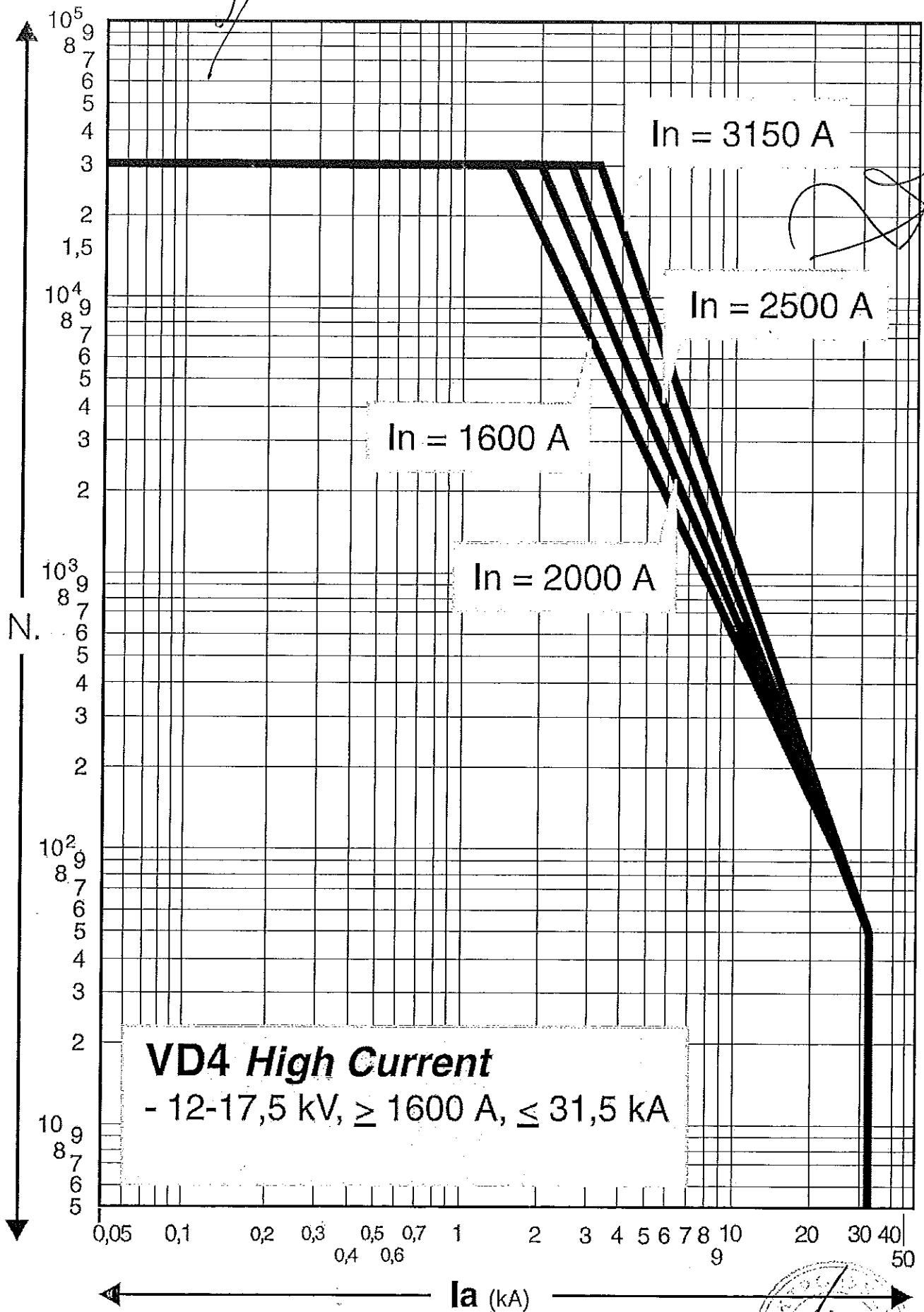

*Handwritten signature*

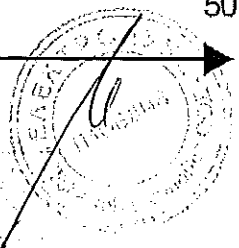

Общи положения	4
Принцип на комутиране	6
Предлагани версии	6
Област на приложение	6
Стандарти и признание	6
Безопасност при обслужване	7
Принадлежности	8
Задвижващ механизъм	8
Техническа документация	10
Система за осигуряване на качество	10
Лабораторни изпитания	10
Програма за екологично управление	10

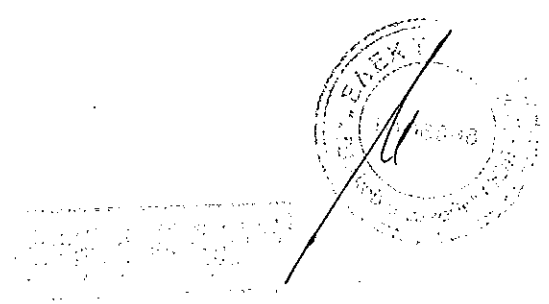

### Общи положения

Новият VD4 е синтез от най-добрите традиции в проектирането и конструирането на вакуумни камери с полюси от смола и в прецизността на проектирането, инженеринга и производството на прекъсвачи. Прекъсвачите за средно напрежение VD4 използват вакуумни комутиращи устройства, вградени в полюси от смола. Вграждането на комутиращото устройство в смола прави полюсите на прекъсвачите особено здрави и защитава устройството от сътресения, натрупване на прах и влага. Комутационните устройства на прекъсвачите включват в себе си контактите и комутационната камера.

### Прекъсване на ток във вакуум

Вакуумните прекъсвачи не изискват специална изолационна среда за да прекъснат аварийния ток. Всъщност, комутиращите устройства не съдържат вещество, което може да се йонизира.

Във всеки случай при разделяне на контактите се генерира дъга от метални пари, която е съставена изключително от разтопеният и изпарен материал на контактите.

Металните пари се поддържат само от придадената отвън енергия, докато токът не се прекъсне при преминаването през нулата. В момента, в който рязко се намали плътността на тока и след моменталното кондензиране на металните пари, диелектричната якост бързо се възстановява.

По този начин вакуумните прекъсвачи възстановяват изолационната якост и способността си да издържат преходния ток и окончателно гасят дъгата.

Тъй като във вакуумна среда диелектричната якост може да се достигне дори при малки разстояния, прекъсването на контура е гарантирано дори когато

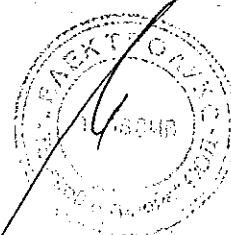
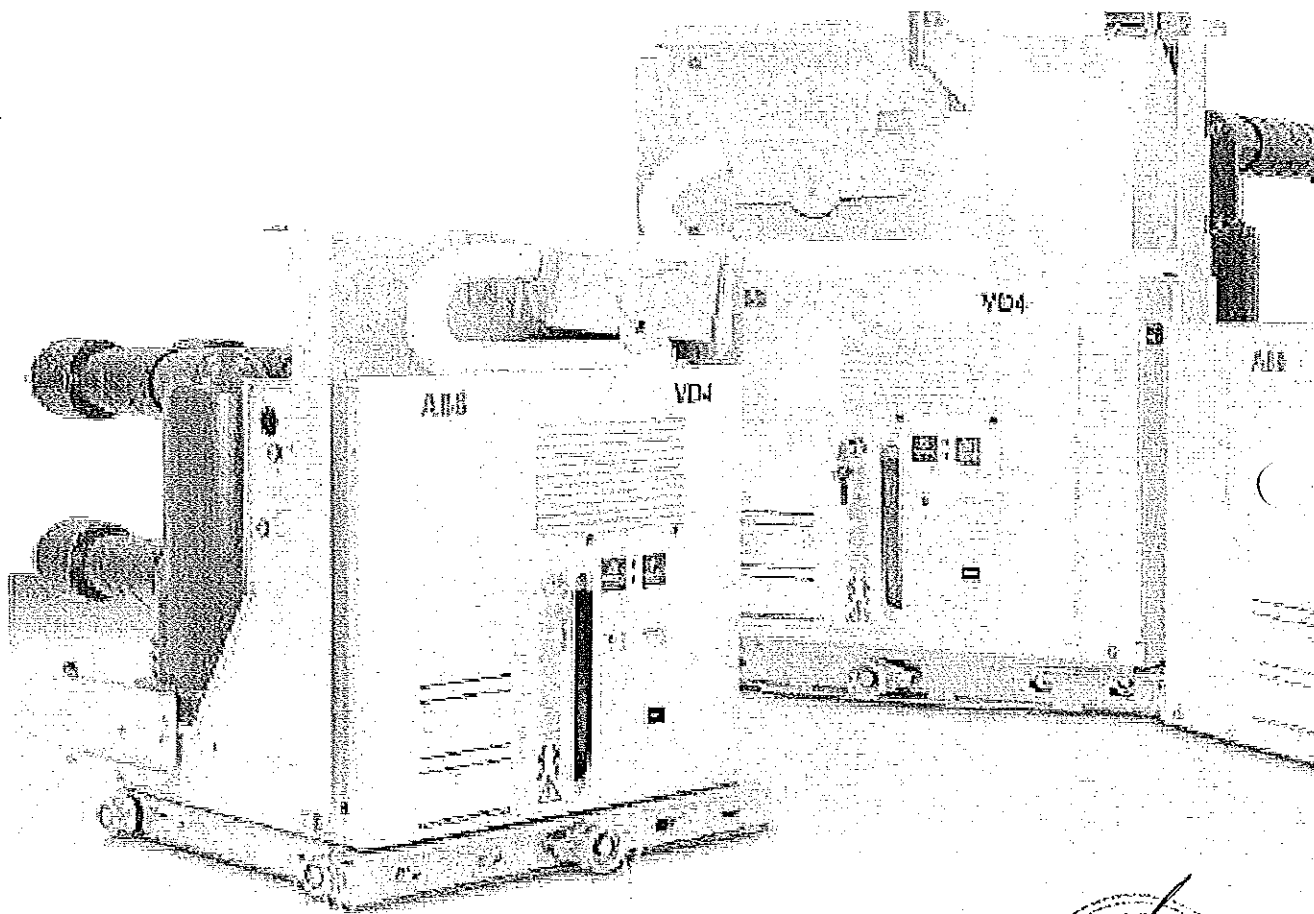



отделянето на контактите става няколко милисекунди преди преминаването на тока през нулата.

Специално проектираните контакти и материали, както и ограничената продължителност и ниското напрежение на дъгата гарантират минимално износване на контактите и техния дълъг живот. Освен това вакуумът предотвратява оксидацията и замърсяването.

### Тип EL задвижващ механизъм

Малката скорост на контактите заедно с намаленото разстояние, което те трябва да преминават и малката маса, ограничават енергията, необходима за задвижването, което гарантира изключително малкото износване на системата. Поради тази причина прекъсвачите VD4 не се нуждаят от особена поддръжка. Прекъсвачите VD4 използват механична енергия за задвижване, с енергия съхраняваща се в освобождаващ механизъм.

Тези характеристики позволяват действията по отварянето и затварянето се извършват независимо от оператор.

Задвижващият механизъм на прекъсвача VD4 е на елементарен принцип и лесен за управление и позволява да бъде оборудван с широка гама от аксесоари с лесно и бързо инсталиране. Простотата на изпълнението води до изключителна надеждност на апарата.

### Конструкция

Задвижващият механизъм и полюсите са закрепени на метална рамка, която поддържа и самото комутиращо устройство в неподменяемите версии. Компактната конструкция осигурява здравина и механична издръжливост. Отделно от първичните контакти и връзката с крайник за схемата на вторичните вериги, подменяемите версии притежават и количка за поставяне и изваждане на прекъсвача в комутационното устройство или за включване към контура на веригата при затворена вратичка.

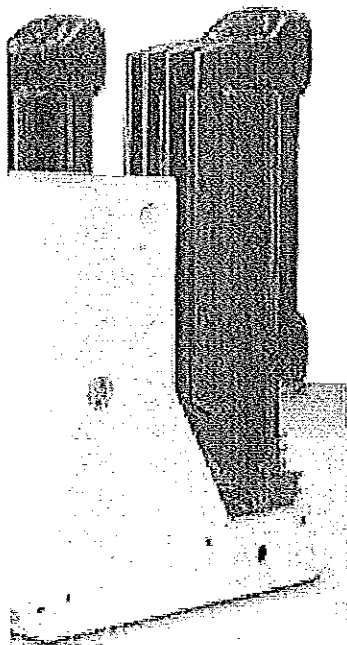

- Вакуумен принцип на комутиране
- Контактите не оксидират във вакуум
- ВДК е вградена в полюси от епоксидна смола
- ВДК е защитена от сътресения, прах и влага
- Работа при различни климатични условия
- Ограничена консумация при комутиране
- Задвижващият механизъм е снабден с неизтощяемо устройство за съхраняване на енергия, по изискванията на стандарта
- Улеснена приспособимост посредством пълна гама аксесоари
- Неподменяеми версии и версии на количка
- Компактни размери
- Трайно запечатани полюси
- Здравина и надеждност
- Ограничена поддръжка
- Поставяне и изваждане на прекъсвача при отворена вратичка
- Благодарение на специалните блокировки в работния механизъм и количката, неправилните и рисковани действия са предотвратени
- Екологично безопасни

Вакуумна дългогасителна камера, вградена в епоксиден полюс

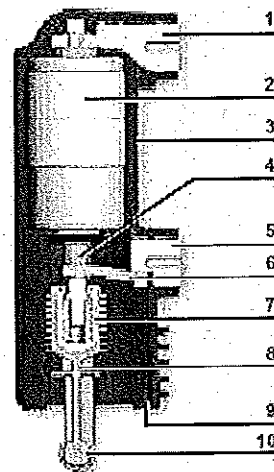

- |                               |                                       |
|-------------------------------|---------------------------------------|
| 1 Горен извод                 | 7 Контакт на задействващите пружини   |
| 2 Вакуумна дългогасяща камера | 8 Избулващ прът                       |
| 3 Кутия от епоксидна смола    | 9 Закрепване                          |
| 4 Шийка на подвижния контакт  | 10 Връзка към задействващия механизъм |
| 5 Долен извод                 |                                       |
| 6 Гъвкава връзка              |                                       |

## ОПИСАНИЕ

### Принцип на гасене на дъгата при прекъсвачите на ABB

Вакуумен прекъсвач

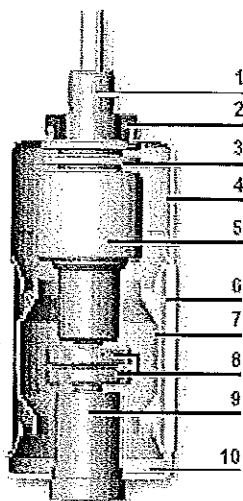

- 1 Шийка/извод
- 2 Защита срещу изкривяване
- 3 Резервоари
- 4 Капак на прекъсвача
- 5 Щит
- 6 Керамичен изолатор
- 7 Щит
- 8 Контакти
- 9 Извод
- 10 Капак на прекъсвача

Във вакуумните прекъсвачи, отделянето на контактите поражда вакуумна дъга, която се поддържа до следващото преминаване на тока през нулата или докато не бъде продухана чрез магнитно поле.

#### Вакуумна дъга- дифузен или концентриран тип

След отделянето на контактите, върху цялата повърхност на катода се образуват отделни точки на разтопяване, които оделят метални пари, поддържащи дъгата. Дифузната вакуумна дъга се характеризира с разширяване над контактната повърхност и с равномерно разпределение на топлинното натоварване върху контактните повърхности.

При номинален ток на вакуумния прекъсвач, електрическата дъга е винаги от дифузен тип. Ерозиите на контактите е пренебрежимо малка, а броя на комутациите, които могат да се извършат е висок.

При нарастване на стойността на комутирания ток (над номиналния ток), в електрическата дъга се наблюдават тенденция към концентриране на дъгата, което се дължи на ефекта на Хол. Запалена при анода, дъгата се концентрира и колкото повече нараства тока, толкова по-концентрирана става тя. Около областта на горене има повишаване на температурата последващо термично натоварване на контактите.

За да се предотврати прегряването и ерозиите на контактите, се поддържа въртене на дъгата. При въртене на дъгата се получава ефект, както при движещ се проводник, по който тече ток.

#### Спирална геометрия на контактите на вакуумните прекъсвачи ABB

Специалната геометрия на спиралните контакти генерира радиално магнитно поле, в областта около канала на дъгата, концентрирано около охръжностите на контактите.

Електромагнитната сила се самогенерира и действа тангенциално, предизвиква бързо въртене на дъгата около оста на контактите.

Това означава, че дъгата е принудена да се върти и да огражда все по-голяма повърхност, отколкото неподвижната концентрирана дъга.

Освен минимизирането на термичното натоварване на контактите, това прави ерозиите на контактите пренебрежимо малка и, преди всичко, прави възможно прекъсване на големи к. с.

Вакуумните прекъсвачи на ABB комутират тока на късо съединение при преминаването му през нулата и не позволяват повторно запалване.

Бързото намаляване на токовото натоварване и бързото кондензиране на металните пари при преминаването на тока през нулата, означава че възстановяването на максималната диелектрична якост между контактите на прекъсвача може да бъде възстановена до няколко микросекунди.

#### Съществуващи версии

Прекъсвачите VD4 имат неподменяема версия и версия на количка, с преден задвижващ механизъм. Версиите на количка се отнасят до комутирани устройства тип UniGear ZS1 и UniSafe.

#### Област на приложение

Прекъсвачите VD4 се използват в разпределителните електрически мрежи за управление и защита на кабелни и въздушни линии, двигатели, трансформатори, генератори и кондензаторни батерии.

#### Стандарти и признания

Прекъсвачите VD4 съответстват на Стандартите IEC 62271-100, CEI 17-1, част 1375 и тези на основните индустриални държави. Прекъсвачите VD4 са преминали тестовете, посочени по-долу и гарантират безопасност и надеждност при работа на апарата при всяка инсталация.

**Типове изпитания:** прегряване, якост на изолацията при индустриална честота, якост на изолацията при мълниеносна дейност, устойчивост на кратковременен и върхов ток, срок на работа на механичните части, устойчивост при ток на късо съединение и максимален ток и комутирание без товар

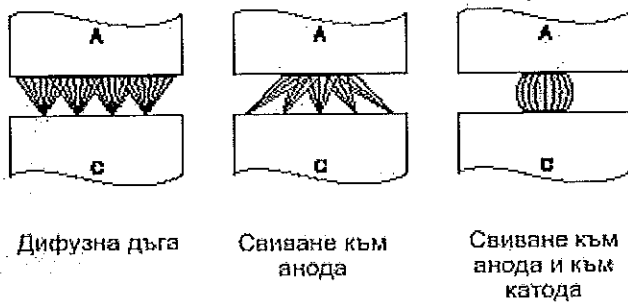
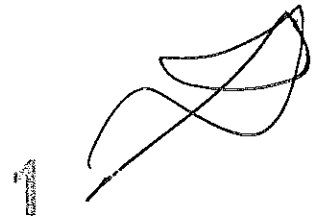
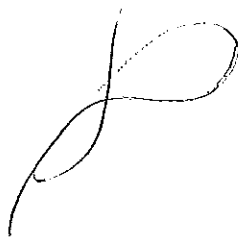

Схематична диаграма на преминаването на дифузната дъга в концентрирана в вакуумните прекъсвачи.

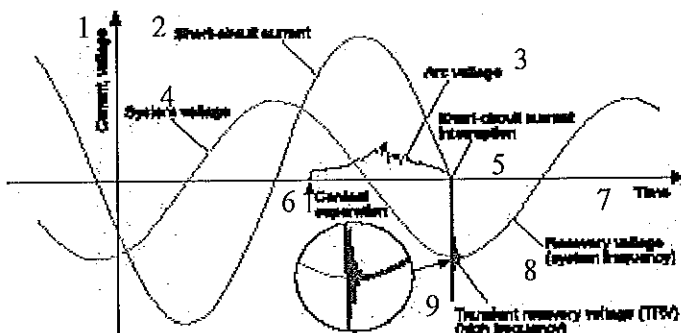

Развитие на тока и напрежението при еднофазно прекъсване.

- |                                     |   |
|-------------------------------------|---|
| 1. Ток, напрежение;                 | 6. Отделяне на контакта   |
| 2. Ток на късо съединение (т.к.с.); | 7. Време;   |
| 3. Напрежение на дъгата;            | 8. Възстановяващо се напрежение (честота на системата);         |
| 4. Напрежение на системата;         | 9. Преходно възстановяващо се напрежение (RTV) с висока честота |
| 5. Прекъсване на т.к.с.;            |   |

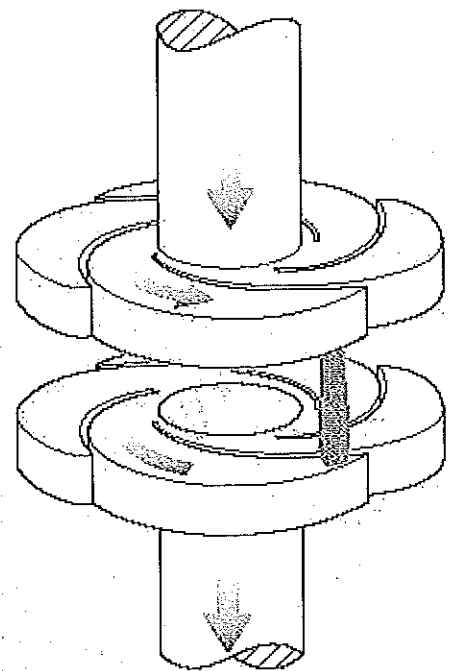

Разположение на контактите един спрямо друг, за формиране на радиално магнитно поле и въртене на дъгата.

• **Индивидуални изпитания:** Изолацията на първичната верига с напрежение на индустриална честота, изолацията на вторичните вериги и задвижващия механизъм, измерване на съпротивлението на първичната верига, механично и електрическо задвижване.

#### Безопасност при работа

Благодарение на предвиждането на всички необходими механични и електрически блокировки (поръчват се допълнително), е възможно към прекъсвачите VD4 да се конструират напълно безопасни разпределителни табла. Блокиращите устройства са разработени за предотвратяване на неправилни зареждания и за съблюдаване на условията, гарантиращи максимална безопасност за оператора.

Блокирането с ключа на таблото или устройство за заключване разрешава действията за "отваряне / затваряне" и "въвеждане / изваждане".

Устройството за изваждане със затворена вратичка позволява прекъсвачът да бъде поставян и изваждан от количката само със затворена вратичка.

Блокировката против изваждане предпазва прекъсвача със затворена вратичка от изваждане и поставяне при различни номинални токове.



## ОПИСАНИЕ

### Акcesoари

Прекъсвачите VD4 притежават пълна гама от акcesoари, за да удовлетворят инсталационните изисквания.

Задвижващият механизъм има стандартизирана гама от акcesoари и резервни части, като изборът и тяхното поръчване е напълно улеснено.

Задвижващите механизми са удобни за инсталиране от лицевата част на прекъсвача.

Електрическият контакт се извършва с връзка от вида щепсел-гнездо. Използването, поддръжката и обслужването на апарата са прости и изискват ограничени ресурси.

### Задвижващ механизъм

Задвижващият механизъм заработва благодарение на съхранена в него енергия, и е съоръжен с устройство против многократно включване, монтирано стандартно и има подходящи блокировки за предотвратяване на неправилни заработвания.

Всяко едно действие се разрешава само в случай, че всички условия, осигуряващи правилното му протичане са налице.

Акcesoарите са същите, както за прекъсвачите тип VD4s.

За да се улесни монтажът и подмяната на акcesoари, върху монтажните легла са добавени подходящи закрепващи езичета.

- Висока надеждност на задвижващия механизъм, благодарение на малкия брой елементи в състава му и поточното им производство в големи количества
- Изключително ограничена и проста поддръжка
- Акcesoарите са общи за цялата гама и са еднакви за апарати за променлив и постоянен ток
- Електрическите акcesoари се заменят лесно и бързо, благодарение на предварително подготвените кабелни връзки, със собствени щепсел-гнездо контакти
- Стандартизирано механично устройство, не позволяващо утечка
- Вграден пост за зареждане на затварящите пружини
- Ключ за блокиране при отворен прекъсвач
- Защитното капаче на пуш-бутоните за отваряне и затваряне се задействат само посредством специален инструмент
- Заклещващо устройство на превключващите пуш-бутони

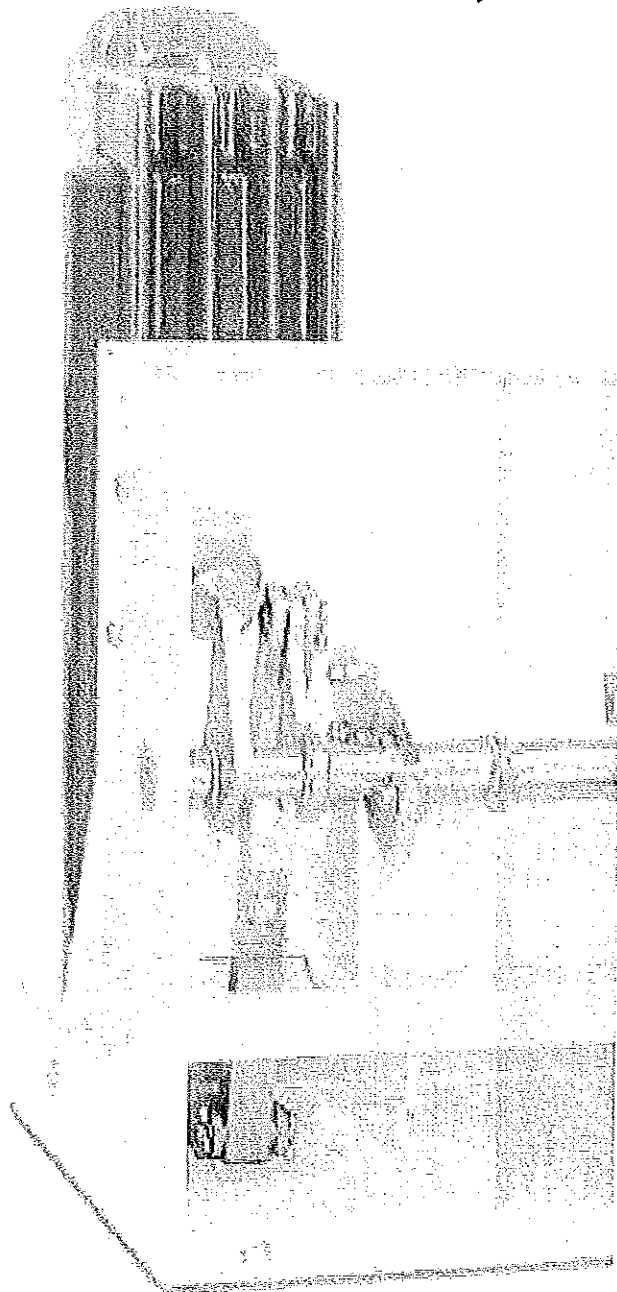

*[Handwritten signature]*

*[Handwritten signature]*

1

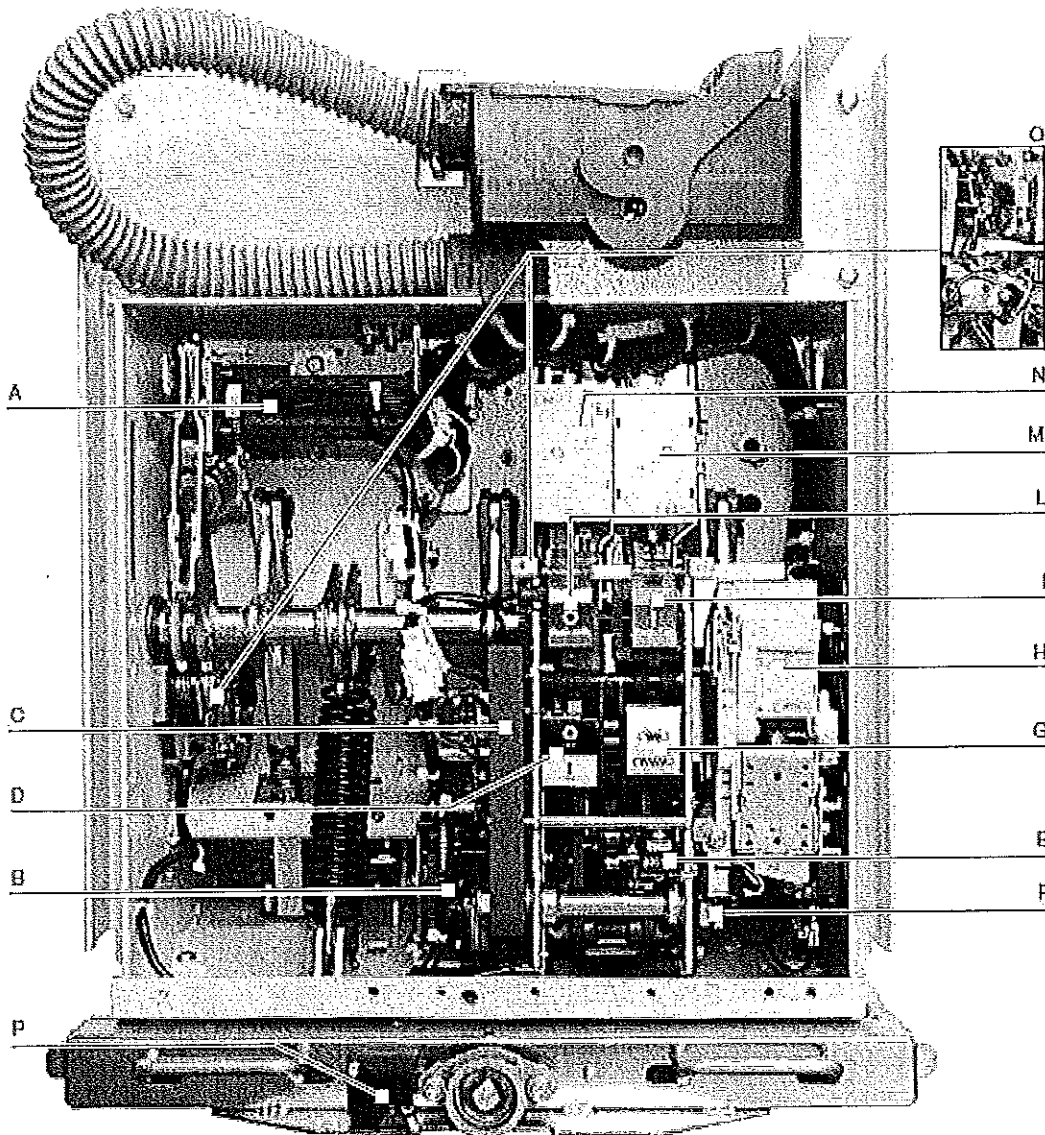

Задвижващ механизъм на прекъсвача

- A Помощни контакти Вкл./Изкл.
- B Мотор за зареждане на включвателна пружина
- C Вграден лост за зареждане на пружината
- D Механично сигнално устройство за прекъсвача изключен/включен
- E Механичен брояч
- F Контакти за сигнализация на заредена/разредена пружина
- G Сигнално устройство за включвателна пружина заредена/разредена
- H Устройство за освобождаване
- I Бутон за включване
- L Бутон за изключване
- M Блокиращ електромагнит за задвижващия механизъм
- N Допълнителна изключвателна бобина – опция
- O Прелитащ контакт
- P Блокировка при отворена врата

*[Handwritten signature]*

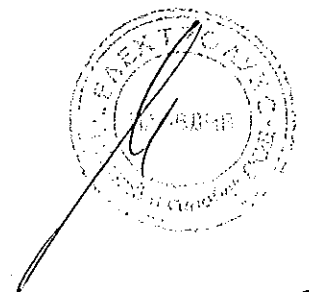

**ОПИСАНИЕ**

**Техническа документация**

За да добиете задълбочено познаване на техническите аспекти на прекъсвачите VD4 и областта им на приложение, моля осведомете се за следните публикации:

- КРУ тип UniSafe	код 649228
- КРУ тип UniGear ZS1	код 649424
- Релейна защита с блок за управл. REFxxx	код 649423
- Релеен блок PR512	код 649092

Система за оценяване на качеството  
Отговаря на Стандартите ISO 9001, сертифициран  
е от независима външна организация.

Изпитваща лаборатория  
Отговаря на Стандартите UNI CEI EN ISO/IEC 17025,  
акредитирана е от външна независима организация

Система за опазване на  
околната среда  
Отговаря на Стандартите ISO 14001,  
сертифицирана е от независима  
външна организация.

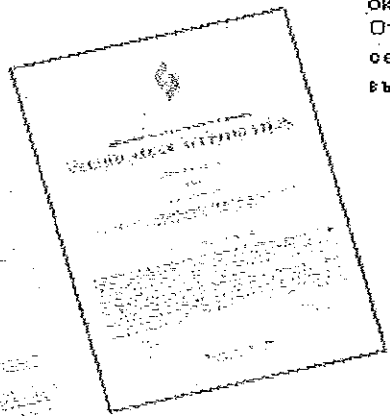
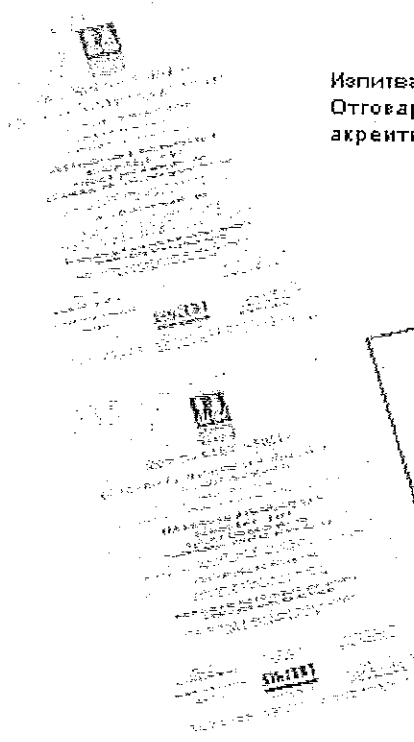

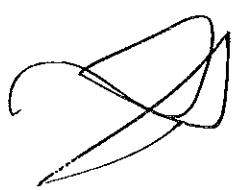
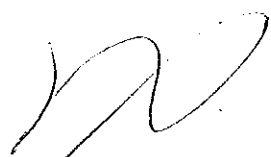

Приложение 1.1 помощен  
документ\_CA\_VD4-  
50kA(EN)V\_1VCP000001\_DigiPrint

( )

( )

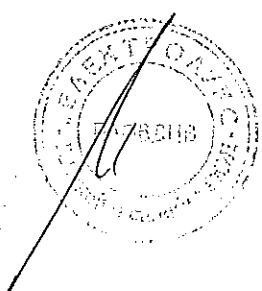

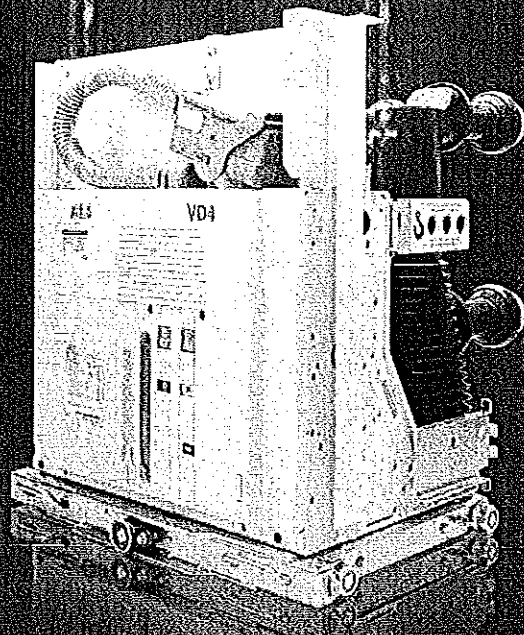

Medium voltage products

Power and productivity  
for a better world™





# Index

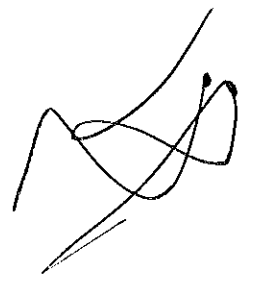
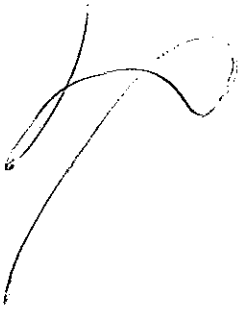

4	1. Description
12	2. Selection and ordering
66	3. Specific product characteristics
70	4. Overall dimensions
96	5. Electric circuit diagram

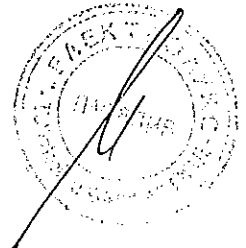

# 1. Description

The new VD4 are a synthesis of renowned technology in designing and constructing vacuum interrupters embedded in poles, and excellency in design, engineering and production of circuit-breakers.

The VD4 medium voltage circuit-breakers use vacuum interrupters embedded in the poles. This construction technique makes the circuit-breaker poles particularly sturdy and protects the interrupter from impacts, dust deposits and humidity. The vacuum interrupter houses the contacts and makes up the interrupting chamber.

## Current interruption in vacuum

The vacuum circuit-breaker does not require an interrupting and insulating medium. In fact, the interrupters do not contain ionisable material.

In any case, on separation of the contacts an electric arc is generated made up exclusively of melted and vaporised contact material.

The electric arc remains supported by the external energy until the current is cancelled in the vicinity of natural zero. At that instant, the rapid reduction in the load density carried and the rapid condensation of the metallic vapour, leads to extremely rapid recovery of the dielectric characteristics. The vacuum interrupter therefore recovers the insulating capacity and the capacity to withstand the transient recovery voltage, definitively extinguishing the arc.

Since high dielectric strength can be reached in the vacuum,

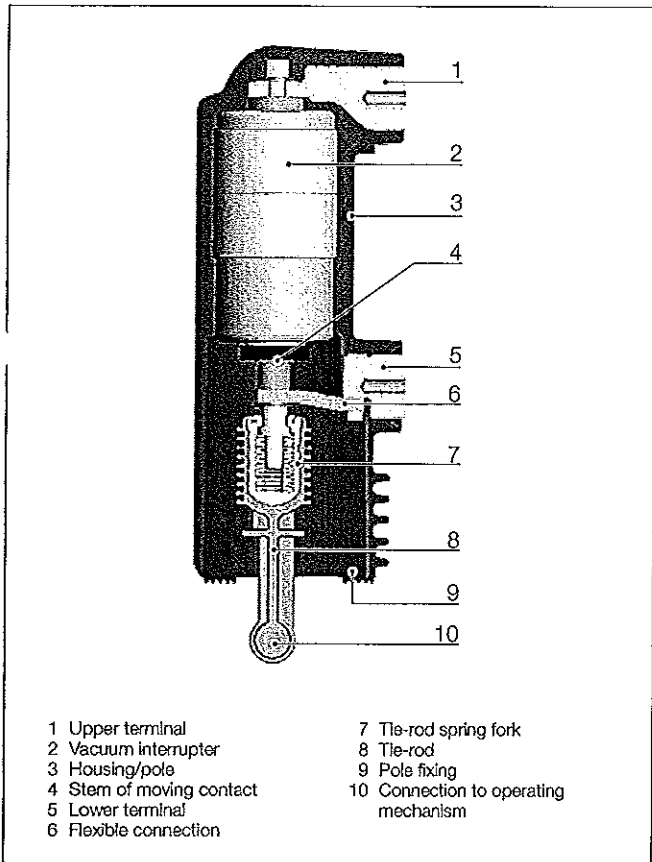

- Vacuum interruption technique
- Vacuum contacts protected against oxidation and contamination
- Vacuum interrupter embedded in the pole
- Interrupter protected against shocks, dust and humidity
- Operation under different climatic conditions
- Limited switching energy
- Stored energy operating mechanism with anti-pumping device supplied as standard
- Simple customisation with a complete range of accessories
- Fixed and withdrawable version
- Compact dimensions
- Sealed-for-life poles
- Sturdiness and reliability
- Limited maintenance
- Circuit-breaker racking in and racking out with door closed
- Incorrect and hazardous operations are prevented thanks to special locks in the operating mechanism and in the truck
- High environmental compatibility

Vacuum interrupter embedded in the pole

*[Handwritten signature]*

*[Handwritten signature]*

even with minimum distances, interruption of the circuit is also guaranteed when separation of the contacts takes place a few milliseconds before passage of the current through natural zero.

The special geometry of the contacts and the material used, as well as the limited duration and low voltage of the arc, guarantee minimum contact wear and long life. Furthermore, the vacuum prevents their oxidation and contamination.

**Operating mechanism**

The low speed of the contacts, together with the reduced run and low mass, limit the energy required for the operation and therefore guarantee extremely limited wear of the system.

The circuit-breaker therefore only requires limited maintenance.

The VD4 circuit-breakers use a mechanical operating mechanism, with stored energy and free trip.

These characteristics allow opening and closing operations independent of the operator. The operating mechanism is of simple conception and use and can be customised with a wide range of accessories which are easy and rapid to install. This simplicity converts into greater reliability of the apparatus.

**The structure**

The operating mechanism and the poles are fixed to a metal frame which is also the support for the fixed version of the circuit-breaker. The compact structure ensures sturdiness and mechanical reliability.

Apart from the isolating contacts and the cord with plug for connection of the auxiliary circuits, the withdrawable version is completed with the truck for racking it into and out of the switchgear or enclosure with the door closed.

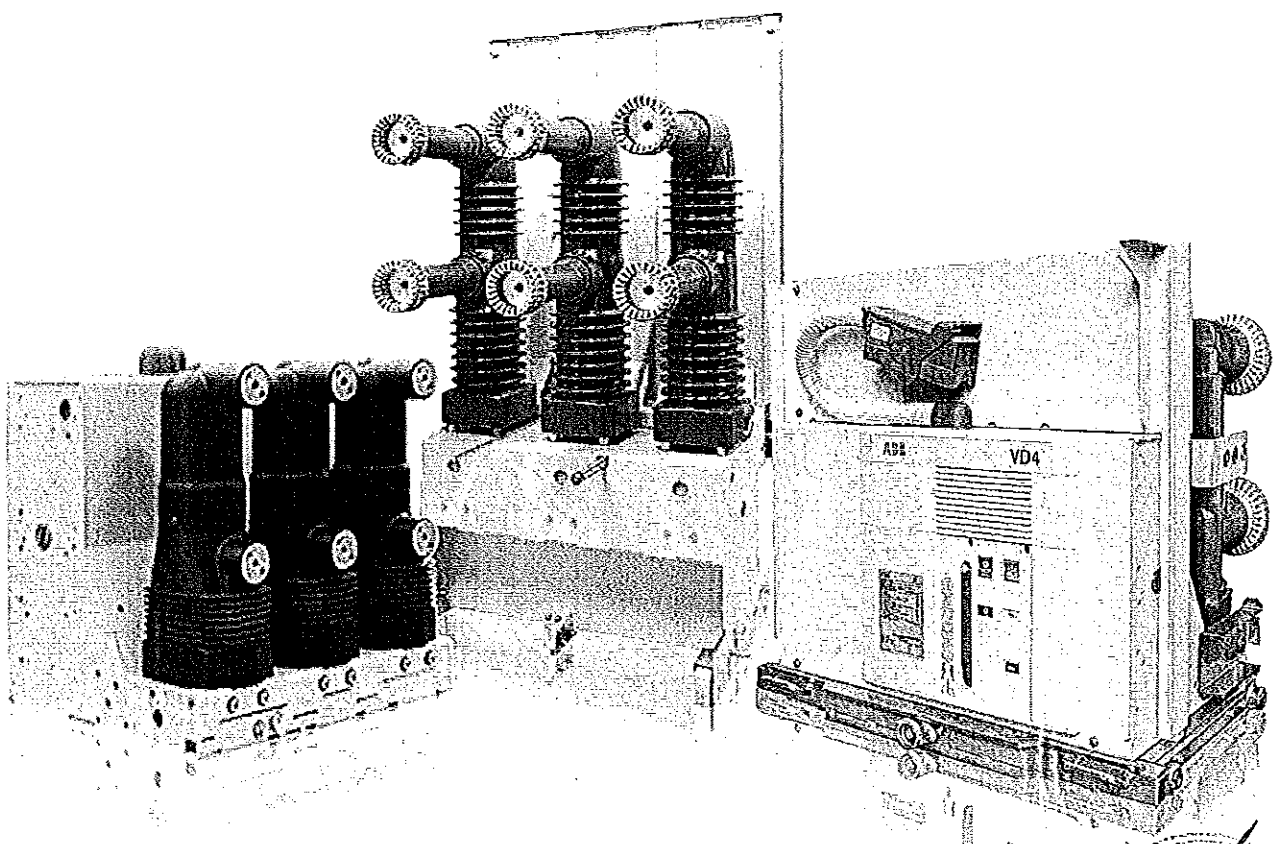

*[Handwritten signature]*

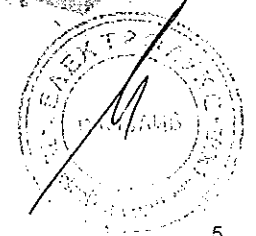

# 1. Description

## Quenching principle of ABB interrupters

In a vacuum interrupter, the electric arc starts at the moment of contact separation and is maintained until zero current and can be influenced by magnetic fields.

### Vacuum arc – diffuse or contracted

Following contact separation, single melting points form over the entire surface of the cathode, producing metal vapours which support the arc.

The diffuse vacuum arc is characterised by expansion over the contact surface and by an even distribution of thermal stress on the contact surfaces.

At the rated current of the vacuum interrupter, the electric arc is always of the diffuse type. Contact erosion is very limited and the number of current interruptions very high.

As the interrupted current value increases (above the rated value), the electric arc tends to be transformed from the diffuse into the contracted type, due to the Hall effect.

Starting at the anode, the arc contracts and as the current rises further it tends to become sharply defined. Near the area involved there is an increase in temperature with consequent thermal stress on the contact.

To prevent overheating and erosion of the contacts, the arc is kept rotating. With arc rotation it becomes similar to a moving conductor which the current passes through.

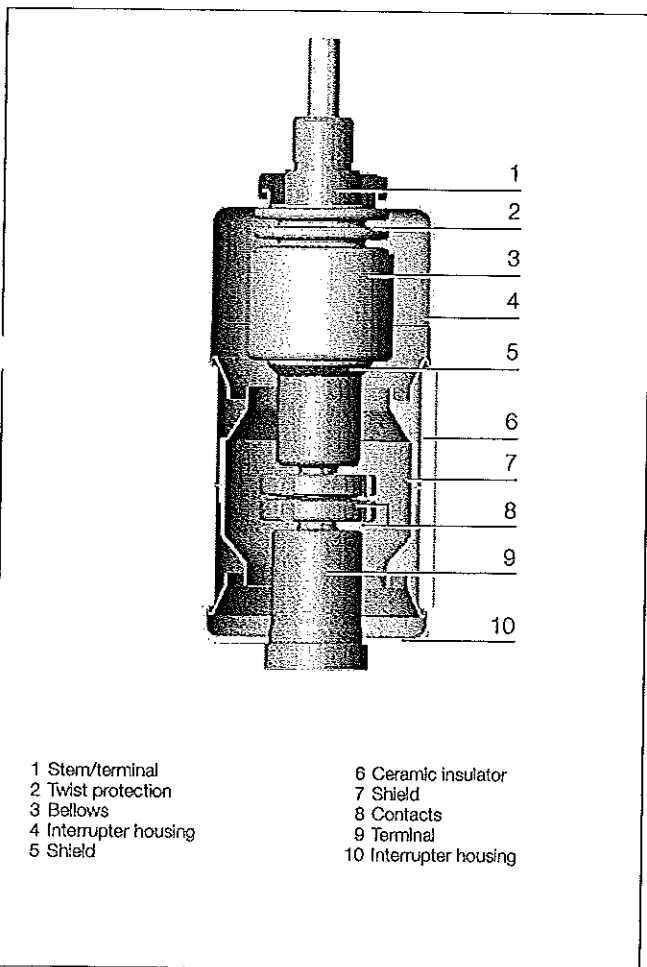

- |                       |                        |
|-----------------------|------------------------|
| 1 Stem/terminal       | 6 Ceramic insulator    |
| 2 Twist protection    | 7 Shield               |
| 3 Bellows             | 8 Contacts             |
| 4 Interrupter housing | 9 Terminal             |
| 5 Shield              | 10 Interrupter housing |

Vacuum Interrupter

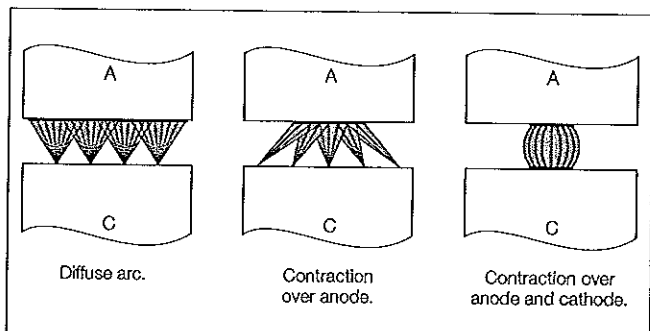

Schematic diagram of the transition from a diffuse arc to a contracted arc in a vacuum interrupter.

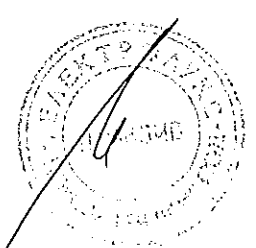

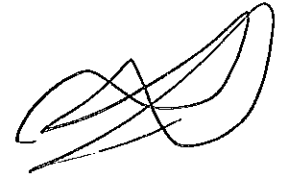
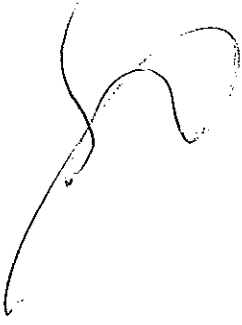

**The spiral geometry of ABB vacuum interrupter contacts**  
 The special geometry of the spiral contacts generates a radial magnetic field in all areas of the arc column, concentrated over the contact circumferences.  
 An electromagnetic force is self-generated and this acts tangentially, causing rapid arc rotation around the contact axis.  
 This means the arc is forced to rotate and to involve a wider surface than that of a fixed contracted arc.

Apart from minimising thermal stress on the contacts, all this makes contact erosion negligible and, above all, allows the interruption process to be controlled even with very high short-circuits.  
 ABB vacuum interrupters interrupt at the natural passage of the current through zero, thereby preventing the arc from restriking after that event.  
 Rapid reduction in the current charge and rapid condensation of the metal vapours simultaneously with the zero current, allows maximum dielectric strength to be restored between the interrupter contacts within microseconds.

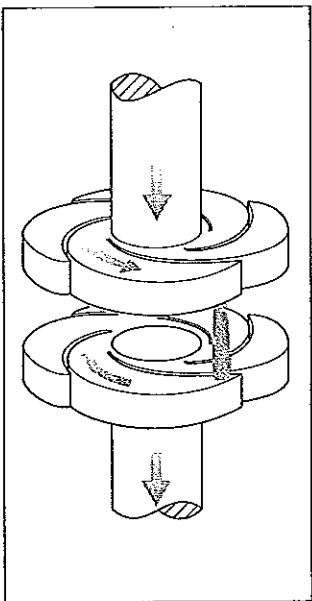

Radial magnetic field contact arrangement with a rotating vacuum arc.

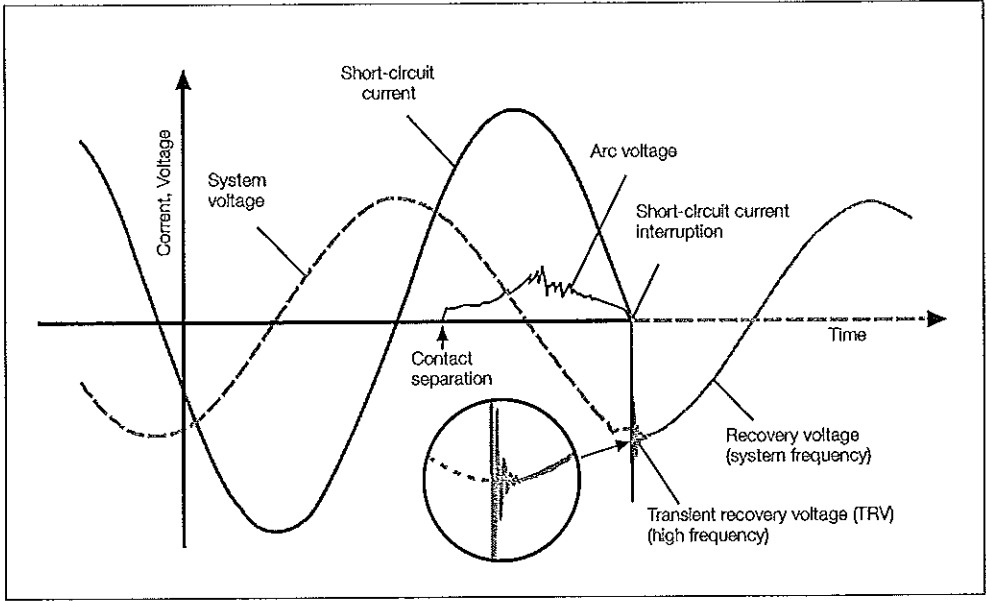

Development of current and voltage trends during a single phase vacuum interruption process.

*M*



# 1. Description

## Versions available

The VD4 circuit-breakers are available in the fixed and withdrawable version with front operating mechanism. The withdrawable version is available for UniGear ZS1, ZS2, ZS8.4 and UniSec switchgear and for PowerCube and Powerbloc enclosures.

## Fields of application

The VD4 circuit-breakers are used in power distribution for control and protection of cables, overhead lines, transformer and distribution substations, motors, transformers, generators and capacitor banks.

## Standards

The VD4 circuit-breakers comply with the IEC 62271-100 Standards and with those of the major industrialised countries.

The VD4 circuit-breakers have undergone the tests indicated below and guarantee the safety and reliability of the apparatus in service in any installation.

- **Type tests:** heating, withstand insulation at power frequency, withstand insulation at lightning impulse, short-time and peak withstand current, mechanical life, short-circuit current making and breaking capacity.
- **Individual tests:** insulation of the main circuits with voltage at power frequency, auxiliary circuit and operating mechanism insulation, measurement of the main circuit resistance, mechanical and electrical operation.

## Service safety

Thanks to the complete range of mechanical and electrical locks (available on request), it is possible to construct safe distribution switchgear with the VD4 circuit-breakers.

The locking devices have been studied to prevent incorrect operations and to inspect the installations whilst guaranteeing maximum operator safety.

Key locks or padlock devices enable opening and closing operations and/or racking in and racking out.

The racking-out device with the door closed allows the circuit-breaker to be racked into or out of the switchgear only with the door closed.

Anti-racking-in locks prevent circuit-breakers with different rated currents from being racked in, and the racking-in and racking out operation with the circuit-breaker closed.

- Highly reliable operating mechanisms thanks to a low number of components which are manufactured using production systems for large quantities
- Extremely limited and simple maintenance
- Accessories common to the entire range
- Electrical accessories that can be easily and quickly installed or replaced thanks to wiring pre-engineered with plug-socket connectors
- Mechanical anti-pumping device is supplied as standard
- Built-in closing spring charging lever
- Key lock with circuit-breaker open
- Protective covering over the opening and closing pushbuttons to be operated using a special tool
- Padlock device on the operating pushbuttons

## Accessories

The VD4 circuit-breakers have a complete range of accessories to satisfy all installation requirements. The operating mechanism has a standardised range of accessories and spare parts which are easy to identify and order.

The accessories are installed conveniently from the front of the circuit-breaker. Electrical connection is carried out with plug-socket connectors.

Use, maintenance and service of the apparatus are simple and require limited use of resources.



*[Handwritten scribble]*

*[Handwritten scribble]*

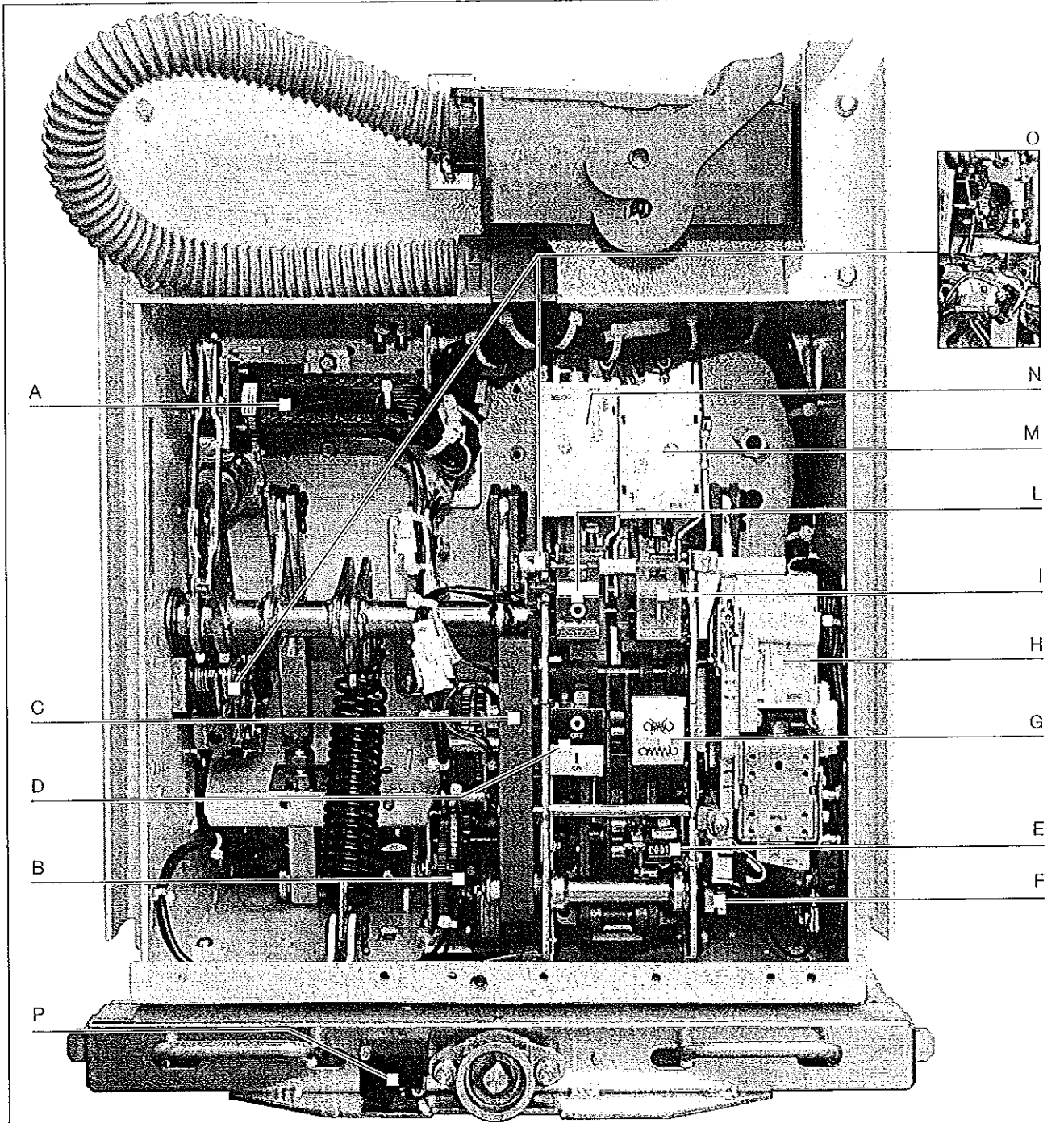

**Circuit-breaker operating mechanism**

- |  |  |
|--|--|
| <p>A Open/closed auxiliary contacts</p> <p>B Geared motor for closing spring charging</p> <p>C Built-in closing spring charging lever</p> <p>D Mechanical signalling device for circuit-breaker open/closed</p> <p>E Mechanical operation counter</p> <p>F Contacts for signalling spring charged/discharged</p> | <p>G Signalling device for closing springs charged/discharged</p> <p>H Service releases</p> <p>I Closing pushbutton</p> <p>L Opening pushbutton</p> <p>M Operating mechanism locking electromagnet</p> <p>N Additional shunt opening release</p> <p>O Transient contact</p> <p>P Lock that prevents racking-in when door is open</p> |
|--|--|

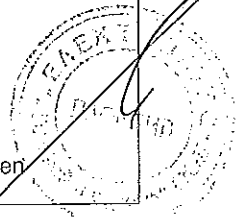

# 1/ Description

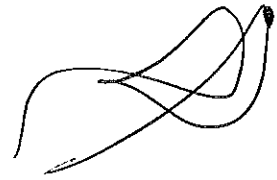

General characteristics of the complete VD4 series (\*)  
 The VD4 series of vacuum circuit-breakers conform to the specifications of the following standards:

- IEC 62271-1
- IEC 62271-100

(\*) For information about the 12 kV • 1250 ... 4000 A • 50/63 kA and 36/40.5 kV • 630 ... 2500 A • 16 ... 40 kA circuit-breakers, please see technical catalogue GCBA520PO102.

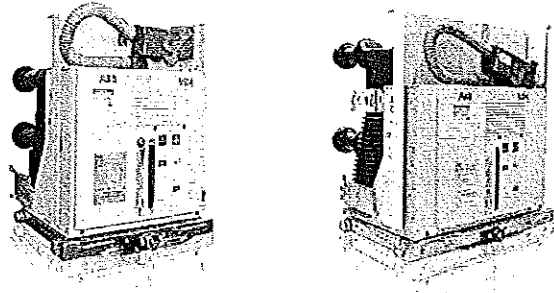

Rated voltage (1)	kV	12			
Rated frequency	Hz	50 - 60			
Rated normal current	A	630 ... 4000 (2)			
Short-time withstand current and breaking capacity	kA	16 ... 31.5	40	50	63
Making capacity	kA	40 ... 80	100	125 (3)	158
Short-time withstand current	s	3	3	3	3
Fixed / withdrawable version		•/•	•/•	•/•	• / -
Maximum overall dimensions (fixed version)	d (mm)	150 - 275	210 - 275	210 - 275	275
	H (mm)	205 - 310	310	310	310
	a (mm)	450 - 700	570 - 700	600 - 750	750
	b (mm)	424	424	459	459
	c (mm)	461 - 599	599 (4)	608 (5)	677
Weight	kg	73 - 105	94 - 180	147 - 260	260
Embedded poles		•	•	•	-
Assembled poles		-	-	-	•

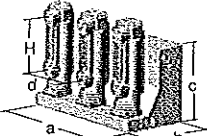

## Technical documentation

To go into technical and application aspects of the VD4 circuit-breakers in depth, please ask us for the following publications:

- PowerCube modules code 1VCP000091
- Powerbloc modules code BA441/03E
- UniGear ZS1 switchgear code 1VCP000138
- ZS8.4 switchgear code L2288
- REF542plus unit code 1VTA100001
- UniSec cod. 1VFM200003

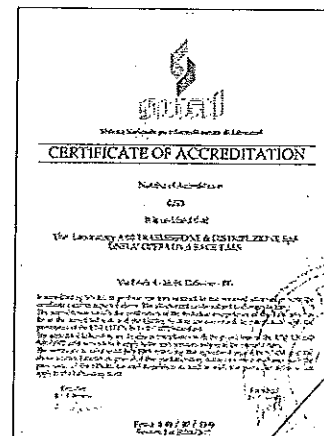
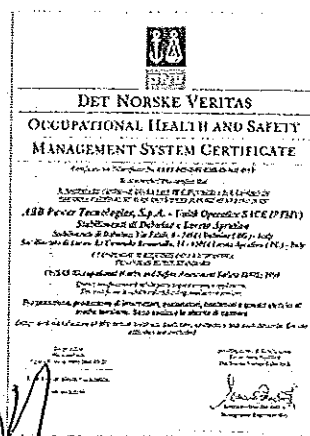
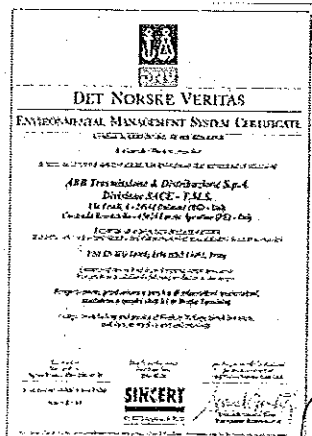
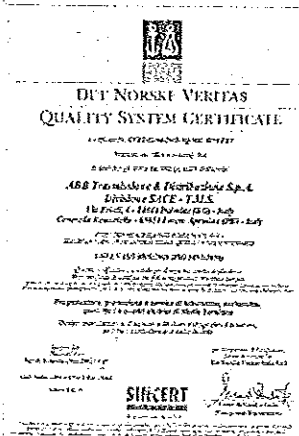



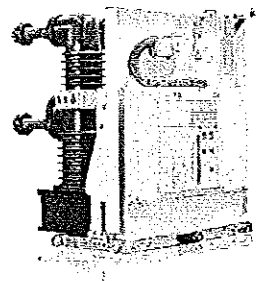
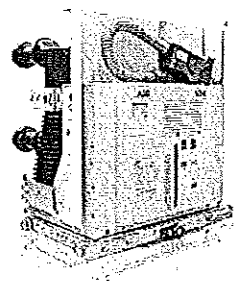
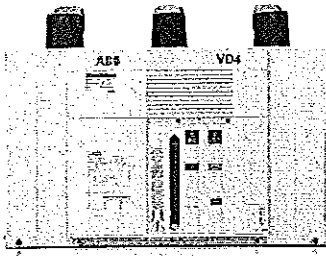

	17,5	24	36	40,5
	50 - 60	50 - 60	50-60	50-60
	630 ... 4000 <sup>(1)</sup>	630 ... 3150 <sup>(2)</sup>	630 ... 3150	630 ... 3150
	16 ... 31,5	40 ... 50	16 ... 31,5	16 ... 40
	40 ... 80	100 ... 125	40 ... 80	40 ... 100
	3	3	3	4
	•/•	•/•	•/•	•/•
	150 - 275	210 - 275	210 - 275	275
	205 - 310	310	310	328 / 280 <sup>(3)</sup>
	450 - 700	570 - 700	570 - 700	786 / 853 <sup>(4)</sup>
	424	424	424	492 / 789 <sup>(5)</sup>
	461 - 599 <sup>(6)</sup>	599 <sup>(6)(7)</sup>	631 - 661	876 / 973 <sup>(6)</sup>
	73 - 105	94 - 180	100 - 110	1575
	•	•	•	•
	-	-	-	•

- <sup>(1)</sup> Test voltage according to IEC 62271-1 Standards table 1a, VDE 0670, - part 1000, list 2
- <sup>(2)</sup> With forced ventilation
- <sup>(3)</sup> Higher values on request
- <sup>(4)</sup> 360 mm for fixed version, 280 mm for withdrawable version
- <sup>(5)</sup> Circuit-breaker with eat sink 616 mm (2500 A)
- <sup>(6)</sup> Withdrawable version
- <sup>(7)</sup> Circuit-breaker with eat sink 634 mm (3150 A)

**Quality System**

Complies with ISO 9001 Standards, certified by an independent organisation.

**Environmental Management System**

Complies with ISO 14001 Standards, certified by an independent organisation.

**Test Laboratory**

Complies with UNI CEI EN ISO/IEC 17025 Standards, accredited by an independent organisation.

**Health and Safety Management System**

Complies with OHSAS 18001 Standards, certified by an independent organisation.

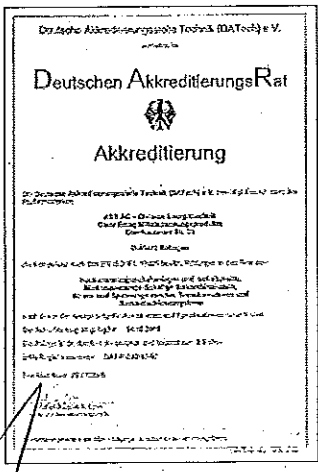
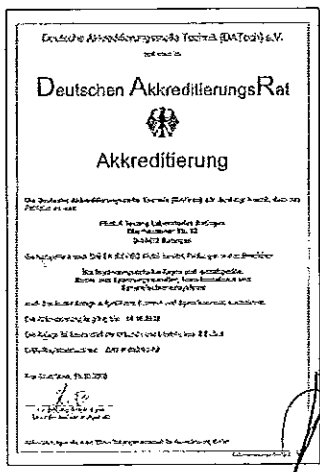
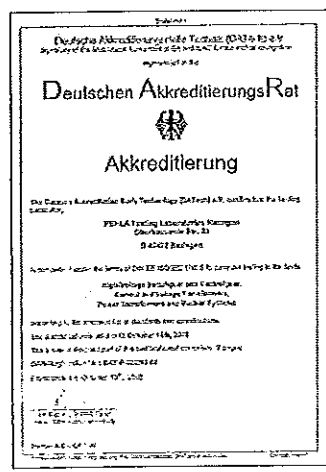

## 2. Selection and ordering Fixed circuit-breakers

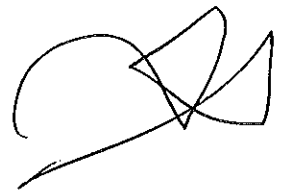

### Fixed VD4 circuit-breaker (12 kV) (4)

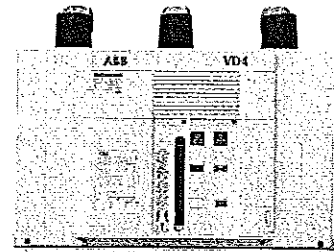

Circuit-breaker		VD4 12									
Standards	IEC 62271-100	•									
Rated voltage	Ur [kV]	12 (2)									
Rated insulation voltage	Us [kV]	12									
Withstand voltage at 50 Hz	Ud (1 min) [kV]	28									
Impulse withstand voltage	Up [kV]	75									
Rated frequency	fr [Hz]	50-60									
Rated normal current (40 °C)	Ir [A]	630	630	630	1250	1250	1250	1250	1250	1250	1250
		16	16	16	16	16	16	—	—	—	—
Rated breaking capacity (rated short-circuit breaking current symmetrical)	Isc [kA]	20	20	20	20	20	20	—	—	—	—
		25	25	25	25	25	25	—	—	—	—
		31.5	31.5	31.5	31.5	31.5	31.5	—	—	—	—
		—	—	—	—	—	—	40	40	—	—
		—	—	—	—	—	—	—	—	50	50
Rated short-time withstand current (3s)	Ik [kA]	16	16	16	16	16	16	—	—	—	—
		20	20	20	20	20	20	—	—	—	—
		25	25	25	25	25	25	—	—	—	—
		31.5	31.5	31.5	31.5	31.5	31.5	—	—	—	—
		—	—	—	—	—	—	40	40	—	—
Making capacity	Ip [kA]	—	—	—	—	—	—	—	—	50	50
		40	40	40	40	40	40	—	—	—	—
		50	50	50	50	50	50	—	—	—	—
		63	63	63	63	63	63	—	—	—	—
		80	80	80	80	80	80	—	—	—	—
Operation sequence	[O - 0.3 s - CO - 15 s - CO]	•	•	•	•	•	•	•	•	•	•
		•	•	•	•	•	•	•	•	•	•
Opening time	[ms]	33 ... 60									
Arcling time	[ms]	10 ... 15									
Total breaking time	[ms]	43 ... 75									
Closing time	[ms]	30 ... 60									
Maximum overall dimensions	H [mm]	461	461	461	461	461	461	589	589	610	610
	W [mm]	450	570	700	450	570	700	570	700	600	750
	D [mm]	424	424	424	424	424	424	424	424	459	459
	Pole distance P [mm]	150	210	275	150	210	275	210	275	210	275
Weight	[kg]	73	75	79	73	75	79	84	84	146	158
Standardised table of dimensions	TN	7405(1)	7406(1)	—	7405(1)	7406(1)	—	—	—	—	—
	1VCD	—	—	000051(1)	—	—	000051(1)	003282(1)	003285(1)	003440	003441
Operating temperature	[°C]	- 5 ... + 40									
Tropicalization	IEC: 60068-2-30, 60721-2-1	•									
Electromagnetic compatibility	IEC: 62271-1	•									

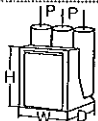

(1) Poles in polyamide

(2) Available in 10 kV voltage version in accordance with GOST standards

(3) Up to 4000 A with forced ventilation

(4) On request, the closing spring can be loaded by means of a removable crank handle outside operating mechanism (instead of linear loading by a lever built into the front of operating mechanism)

•																
12 (°)																
12																
28																
75																
50-60																
1600	1600	1600	1600	1600	1600	1600	1600	2000	2000	2000	2000	2500	2500	2500	3150 (°)	3150 (°)
—	—	—	—	—	—	—	—	—	—	—	—	—	—	—	—	—
20	20	20	—	—	—	—	—	20	20	—	—	20	20	—	20	—
25	25	25	—	—	—	—	—	25	25	—	—	25	25	—	25	—
31.5	31.5	31.5	—	—	—	—	—	31.5	31.5	—	—	31.5	31.5	—	31.5	—
—	—	—	40	40	—	—	—	40	40	—	—	40	40	—	40	—
—	—	—	—	—	50	50	—	—	50	50	—	—	50	—	—	50
—	—	—	—	—	—	—	—	—	—	—	—	—	—	—	—	—
20	20	20	—	—	—	—	—	20	20	—	—	20	20	—	20	—
25	25	25	—	—	—	—	—	25	25	—	—	25	25	—	25	—
31.5	31.5	31.5	—	—	—	—	—	31.5	31.5	—	—	31.5	31.5	—	31.5	—
—	—	—	40	40	—	—	—	40	40	—	—	40	40	—	40	—
—	—	—	—	—	50	50	—	—	50	50	—	—	50	—	—	50
—	—	—	—	—	—	—	—	—	—	—	—	—	—	—	—	—
50	50	50	—	—	—	—	—	50	50	—	—	50	50	—	50	—
63	63	63	—	—	—	—	—	63	63	—	—	63	63	—	63	—
80	80	80	—	—	—	—	—	80	80	—	—	80	80	—	80	—
—	—	—	100	100	—	—	—	100	100	—	—	100	100	—	100	—
—	—	—	—	—	125	125	—	—	125	125	—	—	125	—	—	125
•	•	•	•	•	•	•	•	•	•	•	•	•	•	•	•	•
33 ... 60																
10 ... 15																
43 ... 75																
30 ... 60																
599	599	599	589	589	610	610	599	599	610	610	599	599	610	635	636	
450	570	700	570	700	600	750	570	700	600	750	570	700	750	700	750	
424	424	424	424	424	459	459	424	424	459	459	424	424	459	424	459	
150	210	275	210	275	210	275	210	275	210	275	210	275	275	275	275	
93	98	105	84	84	146	158	98	105	146	158	98	105	163	140	177	
—	7407 (°)	7408 (°)	—	—	—	—	7407 (°)	7408 (°)	—	—	7407 (°)	7408 (°)	—	—	—	
000050	—	—	003282(°)	003285(°)	003440	003441	—	—	003440	003441	—	—	003441	000149 (°)	003443	
- 5 ... + 40																
•																
•																

## 2. Selection and ordering Fixed circuit-breakers

### Fixed VD4 circuit-breaker (17.5 kV) <sup>(3)</sup>

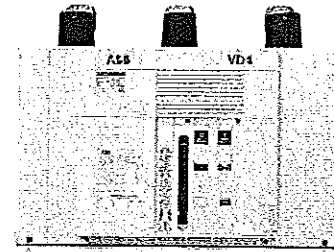

Circuit-breaker		VD4 17									
Standards	IEC 62271-100	•									
Rated voltage	Ur [kV]	17.5									
Rated insulation voltage	Us [kV]	17.5									
Withstand voltage at 50 Hz	Ud (1 min) [kV]	38									
Impulse withstand voltage	Up [kV]	95									
Rated frequency	fr [Hz]	50-60									
Rated normal current (40 °C)	Ir [A]	630	630	630	1250	1250	1250	1250	1250	1250	1250
		16	16	16	16	16	16	—	—	—	—
Rated breaking capacity (rated short-circuit breaking current symmetrical)	Isc [kA]	20	20	20	20	20	20	—	—	—	—
		25	25	25	25	25	25	—	—	—	—
		31.5	31.5	31.5	31.5	31.5	31.5	—	—	—	—
		—	—	—	—	—	—	40	40	—	—
		—	—	—	—	—	—	—	—	50	50
Rated short-time withstand current (3s)	Ik [kA]	16	16	16	16	16	16	—	—	—	—
		20	20	20	20	20	20	—	—	—	—
		25	25	25	25	25	25	—	—	—	—
		31.5	31.5	31.5	31.5	31.5	31.5	—	—	—	—
		—	—	—	—	—	—	40	40	—	—
Making capacity	Ip [kA]	—	—	—	—	—	—	—	—	50	50
		40	40	40	40	40	40	—	—	—	—
		50	50	50	50	50	50	—	—	—	—
		63	63	63	63	63	63	—	—	—	—
		80	80	80	80	80	80	—	—	—	—
Operation sequence	[O - 0.3 s - CO - 15 s - CO]	•	•	•	•	•	•	•	•	•	•
		•	•	•	•	•	•	•	•	•	•
Opening time	[ms]	33 ... 60									
Arcing time	[ms]	10 ... 15									
Total breaking time	[ms]	43 ... 75									
Closing time	[ms]	30 ... 60									
Maximum overall dimensions	H [mm]	461	461	461	461	461	461	589	589	610	610
	W [mm]	450	570	700	450	570	700	570	700	600	750
	D [mm]	424	424	424	424	424	424	424	424	459	459
	Pole distance P [mm]	150	210	275	150	210	275	210	275	210	275
Weight	[kg]	73	75	79	73	75	79	84	84	146	158
Standardised table of dimensions	TN	7405 <sup>(1)</sup>	7406 <sup>(1)</sup>	—	7405 <sup>(1)</sup>	7406 <sup>(1)</sup>	—	—	—	—	—
	1VCD	—	—	000051 <sup>(1)</sup>	—	—	000051 <sup>(1)</sup>	003282 <sup>(1)</sup>	003285 <sup>(1)</sup>	003440	003441
Operating temperature	[°C]	- 5 ... + 40									
Tropicalization	IEC: 60068-2-30, 60721-2-1	•									
Electromagnetic compatibility	IEC: 62271-1	•									

(1) Poles in polyamide

(2) Up to 4000 A with forced ventilation

(3) On request, the closing spring can be loaded by means of a removable crank handle outside operating mechanism (instead of linear loading by a lever built into the front of operating mechanism)

•														
17.5														
17.5														
38														
95														
50-60														
1600	1600	1600	1600	1600	1600	1600	2000	2000	2000	2000	2500	2500	3150 (?)	3150 (?)
-	-	-	-	-	-	-	-	-	-	-	-	-	-	-
20	20	-	-	-	-	-	20	20	-	-	20	-	20	-
25	25	-	-	-	-	-	25	25	-	-	25	-	25	-
31.5	31.5	-	-	-	-	-	31.5	31.5	-	-	31.5	-	31.5	-
-	-	40	40	-	-	-	40	40	-	-	40	-	40	-
-	-	-	-	50	50	-	-	-	50	50	-	50	-	50
-	-	-	-	-	-	-	-	-	-	-	-	-	-	-
20	20	-	-	-	-	-	20	20	-	-	20	-	20	-
25	25	-	-	-	-	-	25	25	-	-	25	-	25	-
31.5	31.5	-	-	-	-	-	31.5	31.5	-	-	31.5	-	31.5	-
-	-	40	40	-	-	-	40	40	-	-	40	-	40	-
-	-	-	-	50	50	-	-	-	50	50	-	50	-	50
-	-	-	-	-	-	-	-	-	-	-	-	-	-	-
50	50	-	-	-	-	-	50	50	-	-	50	-	50	-
63	63	-	-	-	-	-	63	63	-	-	63	-	63	-
80	80	-	-	-	-	-	80	80	-	-	80	-	80	-
-	-	100	100	-	-	-	100	100	-	-	100	-	100	-
-	-	-	-	125	125	-	-	-	125	125	-	125	-	125
•	•	•	•	•	•	•	•	•	•	•	•	•	•	•
33 ... 60														
10 ... 15														
43 ... 75														
30 ... 60														
599	599	589	589	610	610	599	599	610	610	599	610	635	636	
570	700	570	700	600	750	570	700	600	750	700	750	700	750	
424	424	424	424	459	459	424	424	459	459	424	459	424	459	
210	275	210	275	210	275	210	275	210	275	275	275	275	275	
98	105	84	84	146	158	98	105	146	158	105	163	140	177	
7407 (!)	7408 (!)	-	-	-	-	7407 (!)	7408 (!)	-	-	7408 (!)	-	-	-	
-	-	003282 (!)	003285 (!)	003440	003441	-	-	003440	003441	-	003441	000149 (!)	003443	
- 5 ... + 40														
•														
•														

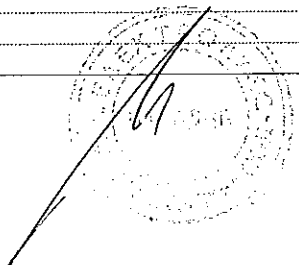

## 2. Selection and ordering Fixed circuit-breakers

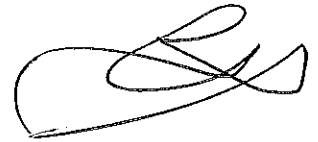

### Fixed VD4 circuit-breaker (24 kV) (2)

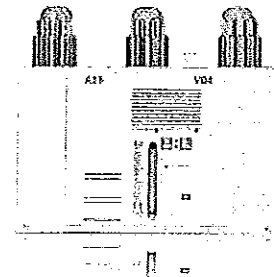

Circuit-breaker		VD4 24						
Standards	IEC 62271-100	•						
Rated voltage	Ur [kV]	24						
Rated insulation voltage	Us [kV]	24						
Withstand voltage at 50 Hz	Ud (1 min) [kV]	50						
Impulse withstand voltage	Up [kV]	125						
Rated frequency	fr [Hz]	50-60						
Rated normal current (40 °C)	Ir [A]	630	630	1250	1250	1600	2000	2500
		16	16	16	16	16	16	--
Rated breaking capacity (rated short-circuit breaking current symmetrical)	Isc [kA]	20	20	20	20	20	20	--
		25	25	25	25	25	25	25
		--	--	31.5	--	31.5	31.5	31.5
Rated short-time withstand current (3s)	Ik [kA]	16	16	16	16	16	16	--
		20	20	20	20	20	20	--
		25	25	25	25	25	25	25
Making capacity	Ip [kA]	--	--	31.5	--	31.5	31.5	31.5
		40	40	40	40	40	40	--
		50	50	50	50	50	50	--
Operation sequence	[O - 0.3 s - CO - 15 s - CO]	63	63	63	63	63	63	63
		--	--	80	--	80	80	80
Opening time	[ms]	33 ... 60						
Arcing time	[ms]	10 ... 15						
Total breaking time	[ms]	43 ... 75						
Closing time	[ms]	30 ... 60						
Maximum overall dimensions	H [mm]	631	631	631	631	642	642	642
	W [mm]	570	700	570	700	700	700	700
	D [mm]	424	424	424	424	424	424	424
	Pole distance P [mm]	210	275	210	275	275	275	275
Weight	[kg]	100	104	100/106 (1)	104	110	110	110
	TN	7409	7410	7409	7410	7411	7411	7411
Standardised table of dimensions	1VCD	--	--	000172 (1)	--	--	--	--
	Operating temperature	[°C]	- 5 ... + 40					
Tropicalization	IEC: 60068-2-30, 60721-2-1	•						
Electromagnetic compatibility	IEC: 62271-1	•						

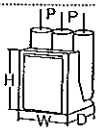

(1) 31.5 kA version

(2) On request, the closing spring can be loaded by means of a removable crank handle outside operating mechanism (instead of linear loading by a lever built into the front of operating mechanism)



Fixed VD4 circuit-breaker (36 kV)

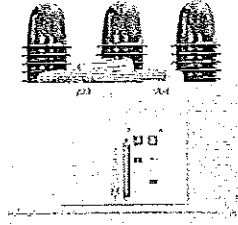

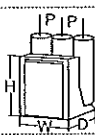
Circuit-breaker		VD4 36				
Standards	IEC 62271-100	•				
Rated voltage	Ur [kV]	36				
Rated insulation voltage	Us [kV]	36				
Withstand voltage at 50 Hz	Ud (1 min) [kV]	70				
Impulse withstand voltage	Up [kV]	170				
Rated frequency	fr [Hz]	50				
Rated normal current (40 °C)	Ir [A]	1250	1600	2000	2500 <sup>(1)</sup>	
		20	20	20	20	
Rated breaking capacity (rated short-circuit breaking current symmetrical)	Isc [kA]	25	25	25	25	
		31.5	31.5	31.5	31.5	
Rated short-time withstand current (3s)	Ik [kA]	20	20	20	20	
		25	25	25	25	
Making capacity	Ip [kA]	31.5	31.5	31.5	31.5	
		50	50	50	50	
Operation sequence	[O - 0.3 s - CO - 15 s - CO]	•	•	•	•	
		•	•	•	•	
Opening time	[ms]	35 ... 60				
Arcing time	[ms]	10 ... 15				
Total breaking time	[ms]	45 ... 75				
Closing time	[ms]	30 ... 60				
Maximum overall dimensions		H [mm]	564	564	564	564
		W [mm]	778	778	778	778
		D [mm]	468	468	468	468
		Pole distance P [mm]	275	275	275	275
Weight	[kg]	150	150	170	170	
Standardised table of dimensions	TN	1VYN300901-LT	1VYN300901-LT	1VYN300901-LT	1VYN300901-LT	
Operating temperature	[°C]	- 5 ... + 40				
Tropicalization	IEC: 60068-2-30, 60721-2-1	•				
Electromagnetic compatibility	IEC: 62271-1	•				

(1) 2500 A with forced ventilation

## 2. Selection and ordering Fixed circuit-breakers

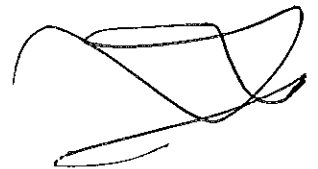

### Types of fixed version circuit-breakers available

Complete the circuit-breaker selected with the optional accessories indicated on the following pages.

#### VD4 fixed circuit-breaker without bottom and top terminals (12 kV)

Ur	Isc	Rated uninterrupted current (40°C) [A]											Circuit-breaker type	
		H=461			H=589		H=599			H=610		H=636		
kV	kA	D=424			D=424		D=424			D=459		D=459		
		u/l=205			u/l=310		u/l=310			u/l=310		u/l=310		
		I/g=217.5			I/g=238		I/g=237.5			I/g=237		I/g=237		
		P=150	P=210	P=275	P=210	P=275	P=150	P=210	P=275	P=210	P=275	P=275		
		W=450	W=570	W=700	W=570	W=700	W=450	W=570	W=700	W=600	W=750	W=750		
12	16	630											VD4 12.06.16 p150	
	20	630											VD4 12.06.20 p150	
	25	630											VD4 12.06.25 p150	
	31.5	630											VD4 12.06.32 p150	
	16	1250											VD4 12.12.16 p150	
	20	1250											VD4 12.12.20 p150	
	25	1250											VD4 12.12.25 p150	
	31.5	1250											VD4 12.12.32 p150	
	20							1600						VD4 12.16.20 p150
	25							1600						VD4 12.16.25 p150
	31.5							1600						VD4 12.16.32 p150
	16		630											VD4 12.06.16 p210
	20		630											VD4 12.06.20 p210
	25		630											VD4 12.06.25 p210
	31.5		630											VD4 12.06.32 p210
	16		1250											VD4 12.12.16 p210
	20		1250											VD4 12.12.20 p210
	25		1250											VD4 12.12.25 p210
	31.5		1250											VD4 12.12.32 p210
	40				1250									VD4 12.12.40 p210
	50									1250				VD4 12.12.50 p210
	20								1600					VD4 12.16.20 p210
	25								1600					VD4 12.16.25 p210
	31.5								1600					VD4 12.16.32 p210
	40					1600								VD4 12.16.40 p210
	50										1600			VD4 12.16.50 p210
	20								2000					VD4 12.20.20 p210
	25								2000					VD4 12.20.25 p210
	31.5								2000					VD4 12.20.32 p210
	40								2000					VD4 12.20.40 p210
50										2000			VD4 12.20.50 p210	
20									2500				VD4 12.25.20 p210	
25									2500				VD4 12.25.25 p210	
31.5									2500				VD4 12.25.32 p210	
40										2500			VD4 12.25.40 p210	

- H = Height of the circuit-breaker.
- W = Width of the circuit-breaker.
- D = Depth of the circuit-breaker.
- u/l = Distance between bottom and top terminal.
- I/g = Distance between the bottom terminal and the resting surface of the circuit-breaker.
- P = Pole horizontal centre distance.

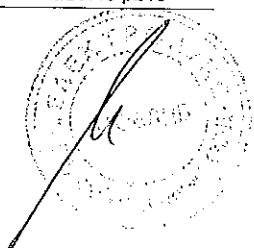
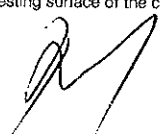



VD4 fixed circuit-breaker without bottom and top terminals (12 kV)

Ur	Isc	Rated uninterrupted current (40°C) [A]											Circuit-breaker type	
		H=461			H=589		H=599			H=610		H=636		
kV	kA	D=424			D=424		D=424			D=459		D=459		
		u/l=205			u/l=310		u/l=310			u/l=310		u/l=310		
		I/g=217.5			I/g=238		I/g=237.5			I/g=237		I/g=237		
		P=150	P=210	P=275	P=210	P=275	P=150	P=210	P=275	P=210	P=275	P=275		
		W=450	W=570	W=700	W=570	W=700	W=450	W=570	W=700	W=600	W=750	W=750		
12	16			630									VD4 12.06.16 p275	
	20			630									VD4 12.06.20 p275	
	25			630									VD4 12.06.25 p275	
	31.5			630									VD4 12.06.32 p275	
	16			1250									VD4 12.12.16 p275	
	20			1250									VD4 12.12.20 p275	
	25			1250									VD4 12.12.25 p275	
	31.5			1250									VD4 12.12.32 p275	
	40					1250							VD4 12.12.40 p275	
	50										1250		VD4 12.12.50 p275	
	20									1600			VD4 12.16.20 p275	
	25									1600			VD4 12.16.25 p275	
	31.5									1600			VD4 12.16.32 p275	
	40						1600						VD4 12.16.40 p275	
	50										1600		VD4 12.16.50 p275	
	20									2000			VD4 12.20.20 p275	
	25									2000			VD4 12.20.25 p275	
	31.5									2000			VD4 12.20.32 p275	
	40									2000			VD4 12.20.40 p275	
	50										2000		VD4 12.20.50 p275	
20									2500			VD4 12.25.20 p275		
25									2500			VD4 12.25.25 p275		
31.5									2500			VD4 12.25.32 p275		
40									2500			VD4 12.25.40 p275		
50										2500		VD4 12.25.50 p275		
20											3150 (1)	VD4 12.32.20 p275		
25											3150 (1)	VD4 12.32.25 p275		
31.5											3150 (1)	VD4 12.32.32 p275		
40											3150 (1)	VD4 12.32.40 p275		
50											3150 (1)	VD4 12.32.50 p275		

H = Height of the circuit-breaker.  
W = Width of the circuit-breaker.  
D = Depth of the circuit-breaker.  
u/l = Distance between bottom and top terminal.  
I/g = Distance between the bottom terminal and the resting surface of the circuit-breaker.  
P = Pole horizontal centre distance.  
(1) Up to 4000 A with forced ventilation



## 2. Selection and ordering Fixed circuit-breakers

VD4 fixed circuit-breaker without bottom and top terminals (17.5 kV)

Ur	Isc	Rated uninterrupted current (40 °C) [A]										Circuit-breaker type	
		H=461			H=589		H=599		H=610		H=635		
kV	kA	D=424			D=424		D=424		D=459		D=459		
		u/l=205			u/l=310		u/l=310		u/l=310		u/l=310		
		I/g=217.5			I/g=238		I/g=237.5		I/g=237		I/g=237.5		
		P=150	P=210	P=275	P=210	P=275	P=150	P=210	P=275	P=210	P=275	P=275	
		W=450	W=570	W=700	W=570	W=700	W=450	W=570	W=700	W=600	W=750	W=750	
17.5	16	630											VD4 17.06.16 p150
	20	630											VD4 17.06.20 p150
	25	630											VD4 17.06.25 p150
	31.5	630											VD4 17.06.32 p150
	16	1250											VD4 17.12.16 p150
	20	1250											VD4 17.12.20 p150
	25	1250											VD4 17.12.25 p150
	31.5	1250											VD4 17.12.32 p150
	16		630										VD4 17.06.16 p210
	20		630										VD4 17.06.20 p210
	25		630										VD4 17.06.25 p210
	31.5		630										VD4 17.06.32 p210
	16		1250										VD4 17.12.16 p210
	20		1250										VD4 17.12.20 p210
	25		1250										VD4 17.12.25 p210
	31.5		1250										VD4 17.12.32 p210
	40					1250							VD4 17.12.40 p210
	50									1250			VD4 17.12.50 p210
	20								1600				VD4 17.16.20 p210
	25								1600				VD4 17.16.25 p210
31.5								1600				VD4 17.16.32 p210	
40					1600							VD4 17.16.40 p210	
50									1600			VD4 17.16.50 p210	
20								2000				VD4 17.20.20 p210	
25								2000				VD4 17.20.25 p210	
31.5								2000				VD4 17.20.32 p210	
40								2000				VD4 17.20.40 p210	
50									2000			VD4 17.20.50 p210	

- H = Height of the circuit-breaker.  
 W = Width of the circuit-breaker.  
 D = Depth of the circuit-breaker.  
 u/l = Distance between bottom and top terminal.  
 I/g = Distance between the bottom terminal and the resting surface of the circuit-breaker.  
 P = Pole horizontal centre distance.

VD4 fixed circuit-breaker without bottom and top terminals (17.5 kV)

Ur	Isc	Rated uninterrupted current (40 °C) [A]											Circuit-breaker type
		H=461			H=589		H=599			H=610		H=635	
kV	kA	D=424			D=424		D=424			D=459		D=459	
		u/l=205			u/l=310		u/l=310			u/l=310		u/l=310	
		I/g=217.5			I/g=238		I/g=237.5			I/g=237		I/g=237.5	
		P=150	P=210	P=275	P=210	P=275	P=150	P=210	P=275	P=210	P=275	P=275	
		W=450	W=570	W=700	W=570	W=700	W=450	W=570	W=700	W=600	W=750	W=750	
17.5	16			630									
	20			630									VD4 17.06.20 p275
	25			630									VD4 17.06.25 p275
	31.5			630									VD4 17.06.32 p275
	16			1250									VD4 17.12.16 p275
	20			1250									VD4 17.12.20 p275
	25			1250									VD4 17.12.25 p275
	31.5			1250									VD4 17.12.32 p275
	40					1250							VD4 17.12.40 p275
	50										1250		VD4 17.12.50 p275
	20									1600			VD4 17.16.20 p275
	25									1600			VD4 17.16.25 p275
	31.5									1600			VD4 17.16.32 p275
	40						1600						VD4 17.16.40 p275
	50										1600		VD4 17.16.50 p275
	20									2000			VD4 17.20.20 p275
	25									2000			VD4 17.20.25 p275
	31.5									2000			VD4 17.20.32 p275
	40									2000			VD4 17.20.40 p275
	50										2000		VD4 17.20.50 p275
	20									2500			VD4 17.25.20 p275
	25									2500			VD4 17.25.25 p275
	31.5									2500			VD4 17.25.32 p275
	40									2500			VD4 17.25.40 p275
	50										2500		VD4 17.25.50 p275
	20											3150	VD4 17.32.20 p275
	25											3150	VD4 17.32.25 p275
	31.5											3150	VD4 17.32.32 p275
	40											3150	VD4 17.32.40 p275
	50											3150	VD4 17.32.50 p275

- H = Height of the circuit-breaker.
- W = Width of the circuit-breaker.
- D = Depth of the circuit-breaker.
- u/l = Distance between bottom and top terminal.
- I/g = Distance between the bottom terminal and the resting surface of the circuit-breaker.
- P = Pole horizontal centre distance.
- (1) Up to 4000 A with forced ventilation

## 2. Selection and ordering Fixed circuit-breakers

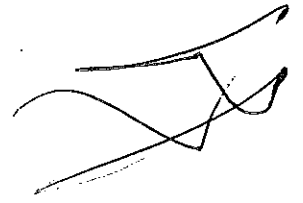

### VD4 fixed circuit-breaker without bottom and top terminals (24 kV)

Ur	Isc	Rated uninterrupted current (40 °C) [A]		Circuit-breaker type	
kV	kA	H=631 D=424 u/l=310 l/g=282.5 P=210 W=570	H=642 D=424 u/l=310 l/g=282.5 P=275 W=700		
24	16	630		VD4 24.06.16 p210	
	20	630		VD4 24.06.20 p210	
	25	630		VD4 24.06.25 p210	
	16	1250		VD4 24.12.16 p210	
	20	1250		VD4 24.12.20 p210	
	25	1250		VD4 24.12.25 p210	
	31.5	1250		VD4 24.12.32 p210	
	16		630	VD4 24.06.16 p275	
	20		630	VD4 24.06.20 p275	
	25		630	VD4 24.06.25 p275	
	16		1250	VD4 24.12.16 p275	
	20		1250	VD4 24.12.20 p275	
	25		1250	VD4 24.12.25 p275	
	16			1600	VD4 24.16.16 p275
	20			1600	VD4 24.16.20 p275
	25			1600	VD4 24.16.25 p275
	31.5			1600	VD4 24.16.32 p275
	16			2000	VD4 24.20.16 p275
	20			2000	VD4 24.20.20 p275
	25			2000	VD4 24.20.25 p275
	31.5			2000	VD4 24.20.32 p275
	25			2500	VD4 24.25.25 p275
	31.5			2500	VD4 24.25.32 p275

- H = Height of the circuit-breaker.
- W = Width of the circuit-breaker.
- D = Depth of the circuit-breaker.
- u/l = Distance between bottom and top terminal.
- l/g = Distance between the bottom terminal and the resting surface of the circuit-breaker.
- P = Pole horizontal centre distance.



**VD4 fixed circuit-breaker without bottom and top terminals (36 kV)**

Ur	isc	Rated uninterrupted current (40 °C) [A]				Circuit-breaker type
kV	kA	H = 876				
		L = 786				
		P = 478.5				
		u/l = 328				
		Vg = 428.5				
		I = 275				
36	20	1250 A				VD4 36.12.20 p275
	25	1250 A				VD4 36.12.25 p275
	31.5	1250 A				VD4 36.12.32 p275
	20		1600 A			VD4 36.16.20 p275
	25		1600 A			VD4 36.16.25 p275
	31.5		1600 A			VD4 36.16.32 p275
	20			2000 A		VD4 36.20.20 p275
	25			2000 A		VD4 36.20.25 p275
	31.5			2000 A		VD4 36.20.32 p275
	20				2500 A <sup>(1)</sup>	VD4 36.25.20 p275
	25				2500 A <sup>(1)</sup>	VD4 36.25.25 p275
	31.5				2500 A <sup>(1)</sup>	VD4 36.25.32 p275

- H = Height of the circuit-breaker.
- W = Width of the circuit-breaker.
- D = Depth of the circuit-breaker.
- u/l = Distance between bottom and top terminal.
- Vg = Distance between the bottom terminal and the resting surface of the circuit-breaker.
- P = Pole horizontal centre distance.
- (1) = 2500 A rated current guaranteed with forced ventilation.

**Standard fittings of fixed circuit-breakers**

The basic versions of the fixed circuit-breakers are three-pole and fitted with:

- EL type manual operating mechanism
  - mechanical signalling device for closing springs charged/discharged
  - mechanical signalling device for circuit-breaker open/closed
  - closing pushbutton, opening pushbutton and operation counter
  - set of ten auxiliary circuit-breaker break/make contacts
- Note: with the group of ten auxiliary contacts supplied as standard and the maximum number of electrical applications, three break contacts (signalling circuit-breaker open) and five make contacts (signalling circuit-breaker closed) are available.
- lever built into operating mechanism for linear loading of closing spring.

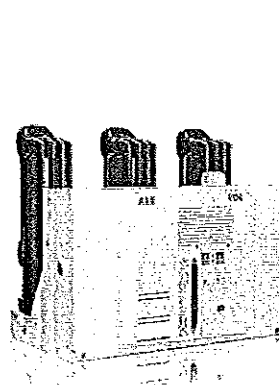

VD4 - up to 24 kV

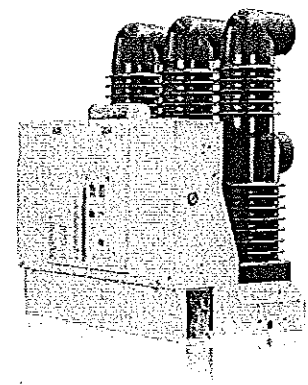

VD4 - 36 kV

(

(

## 2. Selection and ordering Withdrawable circuit-breakers

Withdrawable version circuit-breakers  
for UniGear ZS1 switchgear (12 kV) <sup>(5)</sup>

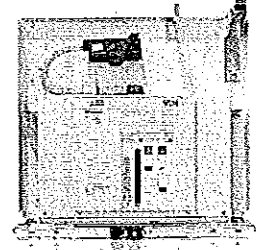

Circuit-breaker		VD4/P 12						
Standards	IEC 62271-100	•						
Rated voltage	Ur [kV]	12 (*)						
Rated insulation voltage	Us [kV]	12						
Withstand voltage at 50 Hz	Ud (1 min) [kV]	28						
Impulse withstand voltage	Up [kV]	75						
Rated frequency	fr [Hz]	50-60						
Rated normal current (40 °C) <sup>(1)</sup>	Ir [A]	630	1250	1250	1250	1250	1600	1600
		16	16	—	—	—	—	—
Rated breaking capacity (rated short-circuit breaking current symmetrical)	Isc [kA]	20	20	—	—	—	20	20
		25	25	—	—	—	25	25
		31.5	31.5	—	—	—	31.5	31.5
		—	—	40	40	—	—	—
		—	—	—	—	50	—	—
Rated short-time withstand current (3s)	Ik [kA]	16	16	—	—	—	—	—
		20	20	—	—	—	20	20
		25	25	—	—	—	25	25
		31.5	31.5	—	—	—	31.5	31.5
		—	—	40	40	—	—	—
Making capacity	I <sub>p</sub> [kA]	40	40	—	—	—	—	—
		50	50	—	—	—	50	50
		63	63	—	—	—	63	63
		80	80	—	—	—	80	80
		—	—	100	100	—	—	—
Operation sequence	[O - 0.3 s - CO - 15 s - CO]	•	•	•	•	•	•	•
Opening time	[ms]	33 ... 60						
Arcing time	[ms]	10 ... 15						
Total breaking time	[ms]	43 ... 75						
Closing time	[ms]	30 ... 60						
Maximum overall dimensions	H [mm]	628	628	691	691	691	691	691
	W [mm]	503	503	653	853	681	653	853
	D [mm]	662	662	641	642	643	642	642
	Pole distance P [mm]	150	150	210	275	210	210	275
Weight	[kg]	116	116	174	176	180	160	166
	TN	7412(*)	7412(*)	—	—	—	7416(*)	7416(*)
Standardised table of dimensions	1VCD	—	—	003284(*)	003286(*)	003444	—	—
Operating temperature	[°C]	- 5 ... + 40						
Tropicalization	IEC: 60068-2-30, 60721-2-1	•						
Electromagnetic compatibility	IEC: 62271-1	•						

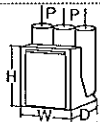

- (1) Rated current guaranteed with circuit-breaker installed in UniGear ZS1 switchgear and with 40 °C ambient temperature.  
 (2) Up to 4000 A with forced ventilation.  
 (3) Poles in polyamide  
 (4) Available in 10 kV voltage version in accordance with GOST standards  
 (5) On request, the closing spring can be loaded by means of a removable crank handle outside operating mechanism (instead of linear loading, only possible with the door open, by means of a lever built into the front of the operating mechanism).

•												
12 (*)												
12												
28												
75												
50-60												
1600	1600	1600	1600	2000	2000	2000	2000	2500	2500	3150 (2)	3150 (2)	
-	-	-	-	-	-	-	-	-	-	-	-	-
-	-	-	-	20	20	-	-	20	-	20	-	-
-	-	-	-	25	25	-	-	25	-	25	-	-
-	-	-	-	31.5	31.5	-	-	31.5	-	31.5	-	-
40	40	-	-	40	40	-	-	40	-	40	-	-
-	-	50	50	-	-	50	50	-	50	-	50	-
-	-	-	-	-	-	-	-	-	-	-	-	-
-	-	-	-	20	20	-	-	20	-	20	-	-
-	-	-	-	25	25	-	-	25	-	25	-	-
-	-	-	-	31.5	31.5	-	-	31.5	-	31.5	-	-
40	40	-	-	40	40	-	-	40	-	40	-	-
-	-	50	50	-	-	50	50	-	50	-	50	-
-	-	-	-	-	-	-	-	-	-	-	-	-
-	-	-	-	50	50	-	-	50	-	50	-	-
-	-	-	-	63	63	-	-	63	-	63	-	-
-	-	-	-	80	80	-	-	80	-	80	-	-
100	100	-	-	100	100	-	-	100	-	100	-	-
-	-	125	125	-	-	125	125	-	125	-	125	-
•	•	•	•	•	•	•	•	•	•	•	•	•
33 ... 60												
10 ... 15												
43 ... 75												
30 ... 60												
691	691	691	691	691	691	691	691	691	691	730	742	
653	853	681	853	653	853	681	853	853	853	853	853	
641	642	643	643	642	642	643	643	640	643	640	643	
210	275	210	275	210	275	210	275	275	275	275	275	
174	176	180	193	160	166	190	205	186	225	221	240	
-	-	-	-	7415(2)	7416(2)	-	-	7417(2)	-	-	-	
003284(2)	003286(2)	003444	003445	-	-	003444	003445	-	003446	000153(2)	003447	
- 5 ... + 40												
•												
•												

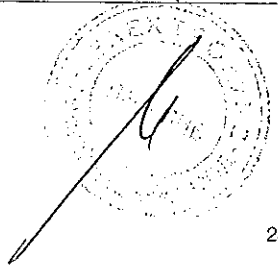



## 2. Selection and ordering Withdrawable circuit-breakers

Withdrawable version circuit-breakers  
for UniGear ZS1 switchgear (17.5 kV) (4)

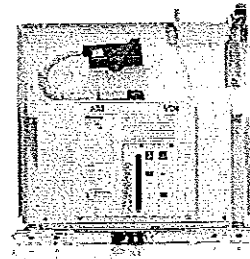

Circuit-breaker		VD4/P 17						
Standards	IEC 62271-100	•						
Rated voltage	Ur [kV]	17,5						
Rated insulation voltage	Us [kV]	17,5						
Withstand voltage at 50 Hz	Ud (1 min) [kV]	38						
Impulse withstand voltage	Up [kV]	95						
Rated frequency	fr [Hz]	50-60						
Rated normal current (40 °C) (1)	Ir [A]	630	1250	1250	1250	1250	1600	1600
		16	16	—	—	—	—	—
Rated breaking capacity (rated short-circuit breaking current symmetrical)	Isc [kA]	20	20	—	—	—	20	20
		25	25	—	—	—	25	25
		31,5	31,5	—	—	—	31,5	31,5
		—	—	40	40	—	—	—
		—	—	—	—	50	—	—
Rated short-time withstand current (3s)	Ik [kA]	16	16	—	—	—	—	—
		20	20	—	—	—	20	20
		25	25	—	—	—	25	25
		31,5	31,5	—	—	—	31,5	31,5
		—	—	40	40	—	—	—
Making capacity	Ip [kA]	—	—	—	—	50	—	—
		40	40	—	—	—	—	—
		50	50	—	—	—	50	50
		63	63	—	—	—	63	63
		80	80	—	—	—	80	80
—	—	100	100	—	—	—		
—	—	—	—	125	—	—		
Operation sequence	[O - 0.3 s - CO - 15 s - CO]	•	•	•	•	•	•	•
Opening time	[ms]	33 ... 60						
Arcing time	[ms]	10 ... 15						
Total breaking time	[ms]	43 ... 75						
Closing time	[ms]	30 ... 60						
Maximum overall dimensions	H [mm]	632	632	691	691	691	691	691
	W [mm]	503	503	653	853	681	653	853
	D [mm]	664	664	641	642	643	642	642
	Pole distance P [mm]	150	150	210	275	210	210	275
Weight	[kg]	116	116	174	176	180	160	166
	TN	7412(2)	7412(2)	—	—	—	7415(2)	7416(2)
Standardised table of dimensions	1VCD	—	—	003284(2)	003286(2)	003444	—	—
Operating temperature	[°C]	- 5 ... + 40						
Tropicalization	IEC: 60068-2-30, 60721-2-1	•						
Electromagnetic compatibility	IEC: 62271-1	•						

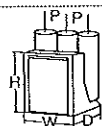

- (1) Rated current guaranteed with circuit-breaker installed in UniGear ZS1 switchgear and with 40 °C ambient temperature.  
 (2) Up to 4000 A with forced ventilation.  
 (3) Poles in polyamide  
 (4) On request, the closing spring can be loaded by means of a removable crank handle outside operating mechanism (instead of linear loading, only possible with the door open, by means of a lever built into the front of the operating mechanism).

•												
17,5												
17,5												
38												
95												
50-60												
1600	1600	1600	1600	2000	2000	2000	2000	2500	2500	3150 <sup>(?)</sup>	3150 <sup>(?)</sup>	
-	-	-	-	-	-	-	-	-	-	-	-	-
-	-	-	-	20	20	-	-	20	-	20	-	-
-	-	-	-	25	25	-	-	25	-	25	-	-
-	-	-	-	31,5	31,5	-	-	31,5	-	31,5	-	-
40	40	-	-	40	40	-	-	40	-	40	-	-
-	-	50	50	-	-	50	50	-	50	-	50	-
-	-	-	-	-	-	-	-	-	-	-	-	-
-	-	-	-	20	20	-	-	20	-	20	-	-
-	-	-	-	25	25	-	-	25	-	25	-	-
-	-	-	-	31,5	31,5	-	-	31,5	-	31,5	-	-
40	40	-	-	40	40	-	-	40	-	40	-	-
-	-	50	50	-	-	50	50	-	50	-	50	-
-	-	-	-	-	-	-	-	-	-	-	-	-
-	-	-	-	50	50	-	-	50	-	50	-	-
-	-	-	-	63	63	-	-	63	-	63	-	-
-	-	-	-	80	80	-	-	80	-	80	-	-
100	100	-	-	100	100	-	-	100	-	100	-	-
-	-	125	125	-	-	125	125	-	125	-	125	-
•	•	•	•	•	•	•	•	•	•	•	•	•
33 ... 60												
10 ... 15												
43 ... 75												
30 ... 60												
691	691	691	691	691	691	691	691	691	691	730	742	
653	853	681	853	653	853	681	853	853	853	853	853	
641	642	643	643	642	642	643	643	640	643	640	643	
210	275	210	275	210	275	210	275	275	275	275	275	
174	176	180	193	160	166	190	205	186	225	221	240	
-	-	-	-	7415 <sup>(?)</sup>	7416 <sup>(?)</sup>	-	-	7417 <sup>(?)</sup>	-	-	-	
003284 <sup>(?)</sup>	003286 <sup>(?)</sup>	003444	003445	-	-	003444	003445	-	003446	000153 <sup>(?)</sup>	003447	
- 5 ... + 40												
•												
•												

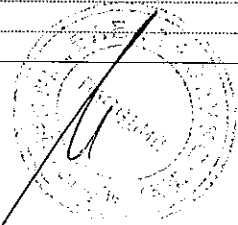

## 2. Selection and ordering Withdrawable circuit-breakers

Withdrawable version circuit-breakers  
for UniGear ZS1 switchgear (24 kV) <sup>(5)</sup>

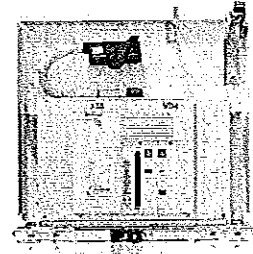

Circuit-breaker		VD4/P 24								
Standards	IEC 62271-100	•								
Rated voltage	Ur [kV]	24								
Rated insulation voltage	Us [kV]	24								
Withstand voltage at 50 Hz	Ud (1 min) [kV]	50								
Impulse withstand voltage	Up [kV]	125								
Rated frequency	fr [Hz]	50-60								
Rated normal current (40 °C) <sup>(1)</sup>	Ir [A]	630	630	1250	1250	1600	2000	2500 <sup>(2)</sup>	3150 <sup>(3)</sup>	
		16	18	16	16	16	16	16	-	
Rated breaking capacity (rated short-circuit breaking current symmetrical)	Isc [kA]	20	20	20	20	20	20	20	-	
		25	25	25	25	25	25	25	-	
		-	-	31,5	31,5	31,5	31,5	31,5	31,5	
Rated short-time withstand current (3s)	Ik [kA]	16	16	16	16	16	16	16	-	
		20	20	20	20	20	20	20	-	
		25	25	25	25	25	25	25	-	
Making capacity	Ip [kA]	-	-	31,5	31,5	31,5	31,5	31,5	31,5	
		40	40	40	40	40	40	40	-	
		50	50	50	50	50	50	50	-	
Operation sequence	[O - 0.3 s - CO - 15 s - CO]	•	•	•	•	•	•	•	•	
		•	•	•	•	•	•	•	•	
Opening time	[ms]	33 ... 60								
Closing time	[ms]	10 ... 15								
Total breaking time	[ms]	43 ... 75								
Closing time	[ms]	30 ... 60								
Maximum overall dimensions		H [mm]	794	794	794	794	838	838	838	838
		W [mm]	653	853	653	853	853	853	853	853
		D [mm]	802	802	802	802	790	790	790	790
		Pole distance P [mm]	210	275	210	275	275	275	275	275
Weight	[kg]	TN	140	148	140/146 <sup>(4)</sup>	148	228	228	228	277
		1VCD	-	-	000173 <sup>(4)</sup>	000174 <sup>(4)</sup>	-	-	-	000177
Standardised table of dimensions										
Operating temperature	[°C]	- 5 ... + 40								
Tropicalization	IEC: 60068-2-30, 60721-2-1	•								
Electromagnetic compatibility	IEC: 62271-1	•								

(1) Rated current guaranteed with circuit-breaker installed in UniGear ZS1 switchgear and with 40 °C ambient temperature.

(2) 2300 A rated current guaranteed with natural ventilation; 2500 A rated current guaranteed with forced ventilation.

(3) 2700 A rated current guaranteed with natural ventilation; 3150 A rated current guaranteed with forced ventilation.

(4) 31.5 kA version.

(5) On request, the closing spring can be loaded by means of a removable crank handle outside operating mechanism (instead of linear loading, only possible with the door open, by means of a lever built into the front of the operating mechanism).

General characteristics of withdrawable circuit-breakers  
for UniGear ZS2 and PowerCube modules (36 kV)

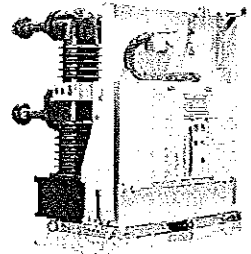

Circuit-breaker		VD4/W 36			
Standards	IEC 62271-100	•			
Rated voltage	Ur [kV]	36			
Rated insulation voltage	Us [kV]	36			
Withstand voltage at 50 Hz	Ud (1 min) [kV]	70			
Impulse withstand voltage	Up [kV]	170			
Rated frequency	fr [Hz]	50			
Rated normal current (40 °C)	Ir [A]	1250	1600	2000	2500 (1)
		20	20	20	20
Rated breaking capacity (rated short-circuit breaking current symmetrical)	Isc [kA]	25	25	25	25
		31.5	31.5	31.5	31.5
Rated short-time withstand current (3s)	Ik [kA]	20	20	20	20
		25	25	25	25
Making capacity	Ip [kA]	31.5	31.5	31.5	31.5
		50	50	50	50
Operation sequence	[O - 0.3 s - CO - 15 s - CO]	•			
Opening time	[ms]	33 ... 60			
Arcing time	[ms]	10 ... 15			
Total breaking time	[ms]	45 ... 75			
Closing time	[ms]	30 ... 60			
Maximum overall dimensions	H [mm]	973	973	973	973
	W [mm]	842	842	842	842
	D [mm]	788	788	788	788
	Pole distance P [mm]	275	275	275	275
Weight	[kg]	230	230	230	230
Standardised table of dimensions	TN	1VYN300901-KG	1VYN300901-KG	1VYN300901-KG	1VYN300901-KG
Operating temperature	[°C]	- 5 ... + 40			
Tropicalization	IEC: 60068-2-30, 60721-2-1	•			
Electromagnetic compatibility	IEC: 62271-1	•			

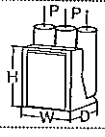

(1) Up to 2500 A with forced ventilation.



## 2. Selection and ordering Withdrawable circuit-breakers

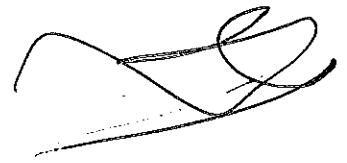

Types of withdrawable version circuit-breakers available for UniGear ZS1 switchgear  
Complete the circuit-breaker selected with the optional accessories indicated on the following pages.

### VD4 (12 kV) withdrawable circuit-breaker

Ur	Isc	Rated uninterrupted current (40 °C) [A]					Circuit-breaker type
		W=650	W=800	W=1000	W=1000	W=1000	
kV	kA	P=150	P=210	P=275	P=275	P=275	
		u/l=205	u/l=310	u/l=310	u/l=310	u/l=310	
		ø=35	ø=79	ø=79	ø=109	ø=109	
12	16	630					VD4/P 12.06.16 p150
	20	630					VD4/P 12.06.20 p150
	25	630					VD4/P 12.06.25 p150
	31.5	630					VD4/P 12.06.32 p150
	16	1250					VD4/P 12.12.16 p150
	20	1250					VD4/P 12.12.20 p150
	25	1250					VD4/P 12.12.25 p150
	31.5	1250					VD4/P 12.12.32 p150
	40		1250				VD4/P 12.12.40 p210
	50		1250				VD4/P 12.12.50 p210
	20		1600				VD4/P 12.16.20 p210
	25		1600				VD4/P 12.16.25 p210
	31.5		1600				VD4/P 12.16.32 p210
	40		1600				VD4/P 12.16.40 p210
	50		1600				VD4/P 12.16.50 p210
	20		2000				VD4/P 12.20.20 p210
	25		2000				VD4/P 12.20.25 p210
	31.5		2000				VD4/P 12.20.32 p210
	40		2000				VD4/P 12.20.40 p210
	50		2000				VD4/P 12.20.50 p210
	40			1250			VD4/P 12.12.40 p275
	20			1600			VD4/P 12.16.20 p275
	25			1600			VD4/P 12.16.25 p275
	31.5			1600			VD4/P 12.16.32 p275
	40			1600			VD4/P 12.16.40 p275
	50			1600			VD4/P 12.16.50 p275
	20			2000			VD4/P 12.20.20 p275
	25			2000			VD4/P 12.20.25 p275
	31.5			2000			VD4/P 12.20.32 p275
	40			2000			VD4/P 12.20.40 p275
50			2000			VD4/P 12.20.50 p275	

W = Switchboard width.  
P = Pole horizontal centre distance.  
u/l = Distance between bottom and top terminal.  
ø = Diameter of the isolating contact.



VD4 (12 kV) withdrawable circuit-breaker

Ur	Isc	Rated uninterrupted current (40 °C) [A]					Circuit-breaker type
		W=650	W=800	W=1000	W=1000	W=1000	
kV	kA	P=160	P=210	P=275	P=275	P=275	
		u/l=205	u/l=310	u/l=310	u/l=310	u/l=310	
		ø=35	ø=79	ø=79	ø=109	ø=109	
12	20				2500		VD4/P 12.25.20 p275
	25				2500		VD4/P 12.25.25 p275
	31,5				2500		VD4/P 12.25.32 p275
	40				2500		VD4/P 12.25.40 p275
	50				2500		VD4/P 12.25.50 p275
	20					3150 <sup>(1)</sup>	VD4/P 12.32.20 p275
	25					3150 <sup>(1)</sup>	VD4/P 12.32.25 p275
	31,5					3150 <sup>(1)</sup>	VD4/P 12.32.32 p275
	40					3150 <sup>(1)</sup>	VD4/P 12.32.40 p275
	50					3150 <sup>(1)</sup>	VD4/P 12.32.50 p275

W = Switchboard width.

P = Pole horizontal centre distance.

u/l = Distance between bottom and top terminal.

ø = Diameter of the isolating contact.

(1) Up to 4000 A with forced ventilation.

## 2. Selection and ordering Withdrawable circuit-breakers

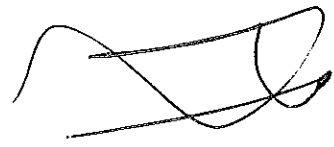

VD4 (17.5 kV) withdrawable circuit-breaker for UniGear ZS1 switchboard

Ur	Isc	Rated uninterrupted current (40 °C) [A]					Circuit-breaker type
		W=650	W=800	W=1000	W=1000	W=1000	
kV	kA	P=150	P=210	P=275	P=275	P=275	
		u/l=205	u/l=310	u/l=310	u/l=310	u/l=310	
		ø=35	ø=79	ø=79	ø=109	ø=109	
17.5	16	630					VD4/P 17.06.16 p150
	20	630					VD4/P 17.06.20 p150
	25	630					VD4/P 17.06.25 p150
	31.5	630					VD4/P 17.06.32 p150
	16	1250					VD4/P 17.12.16 p150
	20	1250					VD4/P 17.12.20 p150
	25	1250					VD4/P 17.12.25 p150
	31.5	1250					VD4/P 17.12.32 p150
	40		1250				VD4/P 17.12.40 p210
	50		1250				VD4/P 17.12.50 p210
	20		1600				VD4/P 17.16.20 p210
	25		1600				VD4/P 17.16.25 p210
	31.5		1600				VD4/P 17.16.32 p210
	40		1600				VD4/P 17.16.40 p210
	50		1600				VD4/P 17.16.50 p210
	20		2000				VD4/P 17.20.20 p210
	25		2000				VD4/P 17.20.25 p210
	31.5		2000				VD4/P 17.20.32 p210
	40		2000				VD4/P 17.20.40 p210
	50		2000				VD4/P 17.20.50 p210
40			1250			VD4/P 17.12.40 p275	
20			1600			VD4/P 17.16.20 p275	
25			1600			VD4/P 17.16.25 p275	
31.5			1600			VD4/P 17.16.32 p275	
40			1600			VD4/P 17.16.40 p275	
50			1600			VD4/P 17.16.50 p275	
20			2000			VD4/P 17.20.20 p275	
25			2000			VD4/P 17.20.25 p275	
31.5			2000			VD4/P 17.20.32 p275	
40			2000			VD4/P 17.20.40 p275	
50			2000			VD4/P 17.20.50 p275	

W = Switchboard width.  
P = Pole horizontal centre distance.  
u/l = Distance between bottom and top terminal.  
ø = Diameter of the isolating contact.



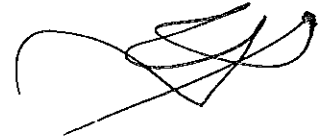

VD4 (17.5 kV) withdrawable circuit-breaker for UniGear ZS1 switchboard

Ur	Isc	Rated uninterrupted current (40 °C) [A]					Circuit-breaker type
		W=650	W=800	W=1000	W=1000	W=1000	
kV	kA	P=150	P=210	P=275	P=275	P=275	
		u/l=205	u/l=310	u/l=310	u/l=310	u/l=310	
		ø=35	ø=79	ø=79	ø=109	ø=109	
17.5	20				2500		VD4/P 17.25.20 p275
	25				2500		VD4/P 17.25.25 p275
	31.5				2500		VD4/P 17.25.32 p275
	40				2500		VD4/P 17.25.40 p275
	50				2500		VD4/P 17.25.50 p275
	20					3150 (1)	VD4/P 17.32.20 p275
	25					3150 (1)	VD4/P 17.32.25 p275
	31.5					3150 (1)	VD4/P 17.32.32 p275
	40					3150 (1)	VD4/P 17.32.40 p275
	50					3150 (1)	VD4/P 17.32.50 p275

W = Switchboard width.  
P = Pole horizontal centre distance.  
u/l = Distance between bottom and top terminal.  
ø = Diameter of the isolating contact.  
(1) Up to 4000 A with forced ventilation.

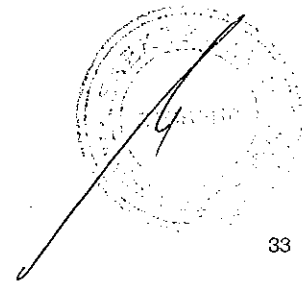



## 2. Selection and ordering Withdrawable circuit-breakers



VD4 (24 kV) withdrawable circuit-breaker for UniGear ZS1 switchboard

Ur	Isc	Rated uninterrupted current (40 °C) [A]				Circuit-breaker type	
		W=800 P=210 u/l=310 ø=35	W=1000 P=275 u/l=310 ø=35	W=1000 P=275 u/l=310 ø=79	W=1000 P=275 u/l=310 ø=109		
kV	16	630				VD4/P 24.06.16 p210	
	20	630				VD4/P 24.06.20 p210	
	25	630				VD4/P 24.06.25 p210	
	16	1250				VD4/P 24.12.16 p210	
	20	1250				VD4/P 24.12.20 p210	
	25	1250				VD4/P 24.12.25 p210	
	31.5	1250				VD4/P 24.12.32 p210	
	24	16		630			VD4/P 24.06.16 p275
		20		630			VD4/P 24.06.20 p275
		25		630			VD4/P 24.06.25 p275
		16		1250			VD4/P 24.12.16 p275
		20		1250			VD4/P 24.12.20 p275
25			1250			VD4/P 24.12.25 p275	
31.5			1250			VD4/P 24.12.32 p275	
16				1600		VD4/P 24.16.16 p275	
20				1600		VD4/P 24.16.20 p275	
25				1600		VD4/P 24.16.25 p275	
31.5				1600		VD4/P 24.16.32 p275	
16				2000		VD4/P 24.20.16 p275	
20			2000		VD4/P 24.20.20 p275		
25			2000		VD4/P 24.20.25 p275		
31.5			2000		VD4/P 24.20.32 p275		
16			2300 <sup>(1)</sup>		VD4/P 24.25.16 p275		
20			2300 <sup>(1)</sup>		VD4/P 24.25.20 p275		
25			2300 <sup>(1)</sup>		VD4/P 24.25.25 p275		
31.5			2300 <sup>(1)</sup>		VD4/P 24.25.32 p275		
31.5				2700 <sup>(2)</sup>	VD4/P 24.32.32 p275		

W = Switchboard width.

P = Pole horizontal centre distance.

u/l = Distance between bottom and top terminal.

ø = Diameter of the isolating contact.

(1) 2500 A rated current guaranteed with forced ventilation.

(2) 3150 A rated current guaranteed with forced ventilation.

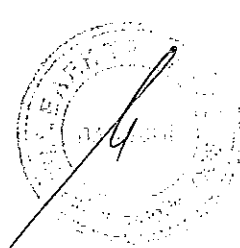

VD4 (36 kV) withdrawable circuit-breaker

Ur	Isc	Rated uninterrupted current (40 °C) [A]			
kV	kA	H = 951			Circuit-breaker type
		D = 788			
		W = 778			
		u/l = 380			
		ø = 399			
		P = 275			
36	20	1250 A			VD4/W 36.12.20 p275
	25	1250 A			VD4/W 36.12.25 p275
	31.5	1250 A			VD4/W 36.12.32 p275
	20		1600 A		VD4/W 36.16.20 p275
	25		1600 A		VD4/W 36.16.25 p275
	31.5		1600 A		VD4/W 36.16.32 p275
	20			2000 A	VD4/W 36.20.20 p275
	25			2000 A	VD4/W 36.20.25 p275
	31.5			2000 A	VD4/W 36.20.32 p275
	20			2500 A (*)	VD4/W 36.25.20 p275
	25			2500 A (*)	VD4/W 36.25.25 p275
	31.5			2500 A (*)	VD4/W 36.25.32 p275

H = Height of the circuit-breaker.  
D = Depth of the circuit-breaker.  
W = Width of the circuit-breaker.  
u/l = Distance between bottom and top terminal.  
ø = Diameter of the isolating contact.  
P = Pole horizontal centre distance.  
(\*) 2500 A rated current guaranteed with forced ventilation

Standard fittings of withdrawable circuit-breakers for UniGear ZS1, ZS2 switchgear and similar panels

The basic versions of the withdrawable circuit-breakers are three-pole and fitted with:

- EL type manual operating mechanism
  - mechanical signalling device for closing springs charged/discharged
  - mechanical signalling device for circuit-breaker open/closed
  - closing pushbutton
  - opening pushbutton
  - operation counter
  - set of ten circuit-breaker open/closed auxiliary contacts
- Note: with the group of ten auxiliary contacts supplied as standard and the maximum number of electrical applications, three break contacts (signalling circuit-breaker open) and four make contacts (signalling circuit-breaker closed) are available.

- lever built into operating mechanism for linear loading of closing spring
- isolating contacts
- cord with connector (plug only) for auxiliary circuits, with striker pins which does not allow the plug to be inserted into the socket if the rated current of the circuit-breaker is lower than the rated current of the panel
- racking-out/in lever (the quantity must be defined according to the number of pieces of apparatus ordered)
- locking electromagnet in the truck (compulsory for ABB switchgear). This device prevents racking the circuit-breaker into the switchgear with the auxiliary circuits disconnected (plug not inserted in the socket)
- door interlock (compulsory for ABB switchgear); this device prevents racking the circuit-breaker into the switchgear when the switchgear door is open.

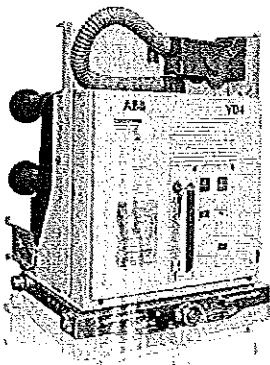

VD4 with poles in polyamide

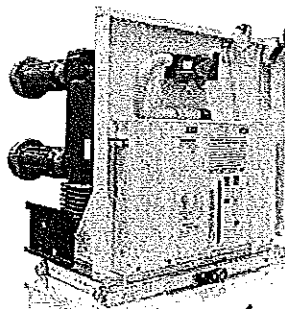

VD4 - up to 24 kV

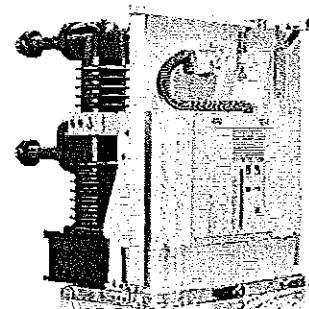

VD4 - 36 kV

## 2. Selection and ordering Withdrawable circuit-breakers

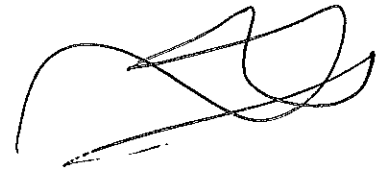

Withdrawable version circuit-breakers  
for PowerCube modules (12 kV) <sup>(5)</sup>

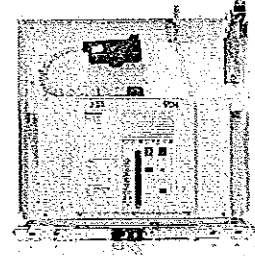

Circuit-breaker	PowerCube module	VD4/P 12		VD4/W 12 <sup>(5)</sup>		
		PB1		PB2		
Standards	IEC 62271-100	•		•		
Rated voltage	Ur [kV]	12 <sup>(4)</sup>		12 <sup>(4)</sup>		
Rated insulation voltage	Us [kV]	12		12		
Withstand voltage at 50 Hz	Ud (1 min) [kV]	28		28		
Impulse withstand voltage	Up [kV]	75		75		
Rated frequency	fr [Hz]	50-60		50-60		
Rated normal current (40 °C) <sup>(1)</sup>	Ir [A]	630	1250	630	1250	
		16	16	16	16	
		20	20	20	20	
		25	25	25	25	
		31.5	31.5	31.5	31.5	
Rated breaking capacity (rated short-circuit breaking current symmetrical)	Isc [kA]	—	—	—	—	
		—	—	—	—	
		16	16	16	16	
		20	20	20	20	
		25	25	25	25	
Rated short-time withstand current (3s)	Ik [kA]	31.5	31.5	31.5	31.5	
		—	—	—	—	
		—	—	—	—	
		16	16	16	16	
		20	20	20	20	
Making capacity	Ip [kA]	25	25	25	25	
		31.5	31.5	31.5	31.5	
		—	—	—	—	
		40	40	40	40	
		50	50	50	50	
Operation sequence	[O - 0.3 s - CO - 15 s - CO]	•		•		
		•		•		
		33 ... 60		33 ... 60		
		10 ... 15		10 ... 15		
		43 ... 75		43 ... 75		
Opening time	[ms]	33 ... 60		33 ... 60		
Arcing time	[ms]	10 ... 15		10 ... 15		
Total breaking time	[ms]	43 ... 75		43 ... 75		
Closing time	[ms]	30 ... 60		30 ... 60		
Maximum overall dimensions		H [mm]	628	628	691	691
		W [mm]	503	503	653	653
		D [mm]	662	662	642	642
		Pole distance P [mm]	150	150	210	210
		Weight	[kg]	116	116	135
Standardised table of dimensions	TN	7412 <sup>(2)</sup>	7412 <sup>(2)</sup>	7420 <sup>(2)</sup>	7420 <sup>(2)</sup>	
	1VCD	—	—	—	—	
Operating temperature	[°C]	- 5 ... + 40		- 5 ... + 40		
Tropicalization	IEC: 60068-2-30, 60721-2-1	•		•		
Electromagnetic compatibility	IEC: 62271-1	•		•		

(1) Rated current guaranteed with circuit-breaker installed in PowerCube enclosure and with 40 °C ambient temperature

(2) Up to 4000 A with forced ventilation.

(3) Poles in polyamide

(4) Available in 10 kV voltage version in accordance with GOST standards

(5) On request, the closing spring can be loaded by means of a removable crank handle outside operating mechanism

(instead of linear loading, only possible with the door open, by means of a lever built into the front of the operating mechanism).

(6) VD4/W does not need insulation for the feed-through and tuip contacts in module PB2. On request, the same circuit-breaker with insulated feed-through and tuip contacts is available for installation in enclosures not produced by ABB (version VD4/PW).

VD4/P 12							VD4/W 12			
PB2							PB3			
•							•			
12 (*)							12 (*)			
12							12			
28							28			
75							75			
50-60							50-60			
1250	1250	1600	1600	1600	2000	2000	2500	2500	3150 (a)	3150 (a)
—	—	—	—	—	—	—	—	—	—	—
—	—	20	—	—	20	—	20	—	20	—
—	—	25	—	—	25	—	25	—	25	—
—	—	31.5	—	—	31.5	—	31.5	—	31.5	—
40	—	—	40	—	40	—	40	—	40	—
—	50	—	—	50	—	50	—	50	—	50
—	—	—	—	—	—	—	—	—	—	—
—	—	20	—	—	20	—	20	—	20	—
—	—	25	—	—	25	—	25	—	25	—
—	—	31.5	—	—	31.5	—	31.5	—	31.5	—
40	—	—	40	—	40	—	40	—	40	—
—	50	—	—	50	—	50	—	50	—	50
—	—	—	—	—	—	—	—	—	—	—
—	—	50	—	—	50	—	50	—	50	—
—	—	63	—	—	63	—	63	—	63	—
—	—	80	—	—	80	—	80	—	80	—
100	—	—	100	—	100	—	100	—	100	—
—	125	—	—	125	—	125	—	125	—	125
•										
33 ... 60							33 ... 60		33 ... 60	
10 ... 15							10 ... 15		10 ... 15	
43 ... 75							43 ... 75		43 ... 75	
30 ... 60							30 ... 60		30 ... 60	
691	691	691	691	691	690	691	691	691	730	691
653	681	653	653	681	653	681	853	853	853	853
641	643	642	641	643	642	643	640	643	640	643
210	210	210	210	210	210	210	275	275	275	275
174	180	160	174	180	160	190	186	225	221	240
—	—	7415 (*)	—	—	7415 (*)	—	7417 (*)	—	—	—
003284 (*)	003444	—	003284 (*)	003444	—	003444	—	003445	000152 (*)	003596
- 5 ... + 40							- 5 ... + 40		- 5 ... + 40	
•							•		•	
•							•		•	

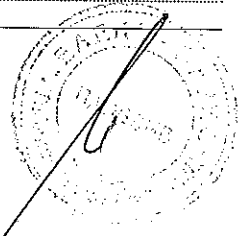

## 2. Selection and ordering Withdrawable circuit-breakers

### Withdrawable version circuit-breakers for PowerCube modules (17.5 kV) <sup>(4)</sup>

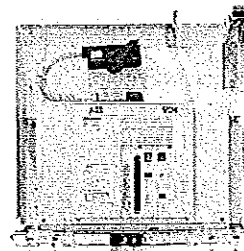

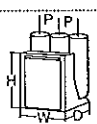
Circuit-breaker	VD4/P 17		VD4/W 17 <sup>(5)</sup>			
	PowerCube module	PB1	PB2			
Standards	IEC 62271-100	•	•			
Rated voltage	Ur [kV]	17,5	17,5			
Rated insulation voltage	Us [kV]	17,5	17,5			
Withstand voltage at 50 Hz	Ud (1 min) [kV]	38	38			
Impulse withstand voltage	Up [kV]	95	95			
Rated frequency	fr [Hz]	50-60	50-60			
Rated normal current (40 °C) <sup>(1)</sup>	Ir [A]	630	1250	630	1250	
		16	16	16	16	
Rated breaking capacity (rated short-circuit breaking current symmetrical)	Isc [kA]	20	20	20	20	
		25	25	25	25	
		31,5	31,5	31,5	31,5	
		—	—	—	—	
		—	—	—	—	
Rated short-time withstand current (3s)	Ik [kA]	16	16	16	16	
		20	20	20	20	
		25	25	25	25	
		31,5	31,5	31,5	31,5	
		—	—	—	—	
Making capacity	Ip [kA]	40	40	40	40	
		50	50	50	50	
		63	63	63	63	
		80	80	80	80	
		—	—	—	—	
Operation sequence	[O - 0.3 s - CO - 15 s - CO]	•	•			
Opening time	[ms]	33 ... 60	33 ... 60			
Arcing time	[ms]	10 ... 15	10 ... 15			
Total breaking time	[ms]	43 ... 75	43 ... 75			
Closing time	[ms]	30 ... 60	30 ... 60			
Maximum overall dimensions		H [mm]	628	628	691	691
		w [mm]	503	503	653	653
		D [mm]	662	662	642	642
		Pole distance P [mm]	150	150	210	210
Weight	[kg]	116	116	135	135	
Standardised table of dimensions	TN	7412 <sup>(2)</sup>	7412 <sup>(2)</sup>	7420 <sup>(2)</sup>	7420 <sup>(2)</sup>	
	1VCD	—	—	—	—	
Operating temperature	[°C]	5 ... + 40	—	- 5 ... + 40		
Tropicalization	IEC: 60068-2-30, 60721-2-1	•	•			
Electromagnetic compatibility	IEC: 62271-1	•	•			

(1) Rated current guaranteed with circuit-breaker installed in PowerCube enclosure and with 40 °C ambient temperature.

(2) Up to 4000 A with forced ventilation.

(3) Poles in polyamide.

(4) On request, the closing spring can be loaded by means of a removable crank handle outside operating mechanism (instead of linear loading, only possible with the door open, by means of a lever built into the front of the operating mechanism).

(5) VD4/W does not need insulation for the feed-through and tulip contacts in module PB2. On request, the same circuit-breaker with insulated feed-through and tulip contacts is available for installation in enclosures not produced by ABB (version VD4/PW).

VD4/P 17							VD4/W 17				
PB2							PB3		PB3		
•							•		•		
17,5							17,5		17,5		
17,5							17,5		17,5		
38							38		38		
95							95		95		
50-60							50-60		50-60		
1250	1250	1600	1600	1600	2000	2000	2500	2500	3150 <sup>(2)</sup>	3150 <sup>(2)</sup>	
—	—	—	—	—	—	—	—	—	—	—	
—	—	20	—	—	20	—	20	—	20	—	
—	—	25	—	—	25	—	25	—	25	—	
—	—	31,5	—	—	31,5	—	31,5	—	31,5	—	
40	—	—	40	—	40	—	40	—	40	—	
—	50	—	—	50	—	50	—	50	—	50	
—	—	—	—	—	—	—	—	—	—	—	
—	—	20	—	—	20	—	20	—	20	—	
—	—	25	—	—	25	—	25	—	25	—	
—	—	31,5	—	—	31,5	—	31,5	—	31,5	—	
40	—	—	40	—	40	—	40	—	40	—	
—	50	—	—	50	—	50	—	50	—	50	
—	—	—	—	—	—	—	—	—	—	—	
—	—	50	—	—	50	—	50	—	50	—	
—	—	63	—	—	63	—	63	—	63	—	
—	—	80	—	—	80	—	80	—	80	—	
100	—	—	100	—	100	—	100	—	100	—	
—	125	—	—	125	—	125	—	125	—	125	
•							•		•		
33 ... 60							33 ... 60		33 ... 60		
10 ... 15							10 ... 15		10 ... 15		
43 ... 75							43 ... 75		43 ... 75		
30 ... 60							30 ... 60		30 ... 60		
691	691	691	691	691	690	691	691	691	730	691	
653	681	653	653	681	653	681	853	853	853	853	
641	643	642	641	643	642	643	640	643	640	643	
210	210	210	210	210	210	210	275	275	275	275	
174	180	160	174	180	160	190	186	225	221	240	
—	—	7415 <sup>(2)</sup>	—	—	7415 <sup>(2)</sup>	—	7417 <sup>(2)</sup>	—	—	—	
003284 <sup>(2)</sup>	003444	—	003284 <sup>(2)</sup>	003444	—	003444	—	003445	000152 <sup>(2)</sup>	003596	
- 5 ... + 40							- 5 ... + 40		- 5 ... + 40		
•							•		•		
•							•		•		

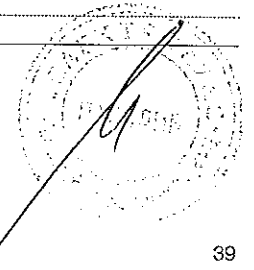

## 2. Selection and ordering Withdrawable circuit-breakers

Withdrawable version circuit-breakers  
for PowerCube modules (24 kV) <sup>(4)</sup>

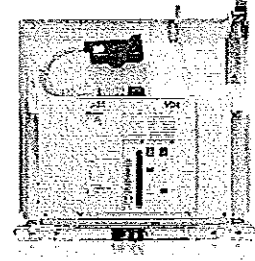

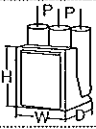
Circuit-breaker	VD4/P 24						
	PowerCube module	PB4		PB5			
Standards	IEC 62271-100	•		•			
Rated voltage	Ur [kV]	24		24			
Rated insulation voltage	Us [kV]	24		24			
Withstand voltage at 50 Hz	Ud (1 min) [kV]	50		50			
Impulse withstand voltage	Up [kV]	125		125			
Rated frequency	fr [Hz]	50-60		50-60			
Rated normal current (40 °C) <sup>(1)</sup>	Ir [A]	630	1250	1600	2000	2500 <sup>(2)</sup>	
		16	16	16	16	16	
Rated breaking capacity (rated short-circuit breaking current symmetrical)	Isc [kA]	20	20	20	20	20	
		25	25	25	25	25	
		-	31,5	31,5	31,5	31,5	
Rated short-time withstand current (3s)	Ik [kA]	16	16	16	16	16	
		20	20	20	20	20	
		25	25	25	25	25	
Making capacity	Ip [kA]	-	31,5	31,5	31,5	31,5	
		40	40	40	40	40	
		50	50	50	50	50	
Operation sequence	[O - 0.3 s - CO - 15 s - CO]	•	•	•	•	•	
		•	•	•	•	•	
Opening time	[ms]	33 ... 60		33 ... 60			
Arcing time	[ms]	10 ... 15		10 ... 15			
Total breaking time	[ms]	43 ... 75		43 ... 75			
Closing time	[ms]	30 ... 60		30 ... 60			
Maximum overall dimensions		H [mm]	794	794	838	838	838
		W [mm]	653	653	853	853	853
		D [mm]	802	802	790	790	790
		Pole distance P [mm]	210	210	275	275	275
Weight	[kg]	140	140/146 <sup>(3)</sup>	228	228	228	
Standardised table of dimensions	TN	7413	7413	7418	7418	7418	
	1VCD	-	000173 <sup>(3)</sup>	-	-	-	
Operating temperature	[°C]	- 5 ... + 40					
Tropicalization	IEC: 60068-2-30, 60721-2-1	•					
Electromagnetic compatibility	IEC: 62271-1	•					

(1) Rated current guaranteed with circuit-breaker installed in PowerCube enclosure and with 40 °C ambient temperature.

(2) 2300 A rated uninterrupted current guaranteed with natural ventilation; 2500 A rated current guaranteed with forced ventilation.

(3) 31.5 kA version.

(4) On request, the closing spring can be loaded by means of a removable crank handle outside operating mechanism (instead of linear loading, only possible with the door open, by means of a lever built into the front of the operating mechanism).

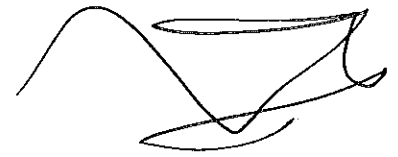

## Types of withdrawable version circuit-breakers available for PowerCube modules

Complete the circuit-breaker selected with the optional accessories indicated on the following pages.

### VD4 withdrawable circuit-breaker (12 kV)

Ur	Isc	Rated uninterrupted current (40 °C) [A]				Circuit-breaker type
		W=650	W=750	W=750	W=1000	
kV	kA	P=150	P=210	P=210	P=275	
		u/l=205	u/l=310	u/l=310	u/l=310	
		ø=35	ø=35	ø=79	ø=109	
12	16	630				VD4/P 12.06.16 p150
	20	630				VD4/P 12.06.20 p150
	25	630				VD4/P 12.06.25 p150
	31.5	630				VD4/P 12.06.32 p150
	16	1250				VD4/P 12.12.16 p150
	20	1250				VD4/P 12.12.20 p150
	25	1250				VD4/P 12.12.25 p150
	31.5	1250				VD4/P 12.12.32 p150
	16		630			VD4/W 12.06.16 p210
	20		630			VD4/W 12.06.20 p210
	25		630			VD4/W 12.06.25 p210
	31.5		630			VD4/W 12.06.32 p210
	16		1250			VD4/W 12.12.16 p210
	20		1250			VD4/W 12.12.20 p210
	25		1250			VD4/W 12.12.25 p210
	31.5		1250			VD4/W 12.12.32 p210
	40			1250		VD4/P 12.12.40 p210
	50			1250		VD4/P 12.12.50 p210
	20			1600		VD4/P 12.16.20 p210
	25			1600		VD4/P 12.16.25 p210
	31.5			1600		VD4/P 12.16.32 p210
	40			1600		VD4/P 12.16.40 p210
	50			1600		VD4/P 12.16.50 p210
	20			2000		VD4/P 12.20.20 p210
	25			2000		VD4/P 12.20.25 p210
	31.5			2000		VD4/P 12.20.32 p210
	40			2000		VD4/P 12.20.40 p210
	50			2000		VD4/P 12.20.50 p210
	20				2500	VD4/P 12.25.20 p275
	25				2500	VD4/P 12.25.25 p275
	31.5				2500	VD4/P 12.25.32 p275
	40				2500	VD4/P 12.25.40 p275
	50				2500	VD4/P 12.25.50 p275
	20				3150 <sup>(1)</sup>	VD4/W 12.32.20 p275
	25				3150 <sup>(1)</sup>	VD4/W 12.32.25 p275
	31.5				3150 <sup>(1)</sup>	VD4/W 12.32.32 p275
	40				3150 <sup>(1)</sup>	VD4/W 12.32.40 p275
	50				3150 <sup>(1)</sup>	VD4/W 12.32.50 p275

W = Enclosure width.  
P = Pole horizontal centre distance.  
u/l = Distance between bottom and top terminal.  
ø = Diameter of the Isolating contact.  
(1) Up to 4000 A with forced ventilation.





## 2. Selection and ordering Withdrawable circuit-breakers

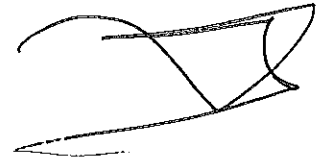

### VD4 withdrawable circuit-breaker (17.5 kV)

Ur	Isc	Rated uninterrupted current (40 °C) [A]				Circuit-breaker type
		W=650 P=150 u/l=205 ø=35	W=750 P=210 u/l=310 ø=35	W=750 P=210 u/l=310 ø=79	W=1000 P=275 u/l=310 ø=109	
kV	kA					
17.5	18	630				VD4/P 17.06.16 p150
	20	630				VD4/P 17.06.20 p150
	25	630				VD4/P 17.06.25 p150
	31.5	630				VD4/P 17.06.32 p150
	16	1250				VD4/P 17.12.16 p150
	20	1250				VD4/P 17.12.20 p150
	25	1250				VD4/P 17.12.25 p150
	31.5	1250				VD4/P 17.12.32 p150
	16		630			VD4/W 17.06.16 p210
	20		630			VD4/W 17.06.20 p210
	25		630			VD4/W 17.06.25 p210
	31.5		630			VD4/W 17.06.32 p210
	16		1250			VD4/W 17.12.16 p210
	20		1250			VD4/W 17.12.20 p210
	25		1250			VD4/W 17.12.25 p210
	31.5		1250			VD4/W 17.12.32 p210
	40			1250	VD4/P 17.12.40 p210	
	50			1250	VD4/P 17.12.50 p210	
	20			1600	VD4/P 17.16.20 p210	
	25			1600	VD4/P 17.16.25 p210	
	31.5			1600	VD4/P 17.16.32 p210	
	40			1600	VD4/P 17.16.40 p210	
	60			1600	VD4/P 17.16.50 p210	
	20			2000	VD4/P 17.20.20 p210	
	25			2000	VD4/P 17.20.25 p210	
	31.5			2000	VD4/P 17.20.32 p210	
	40			2000	VD4/P 17.20.40 p210	
	50			2000	VD4/P 17.20.50 p210	
	20				2500	VD4/P 17.25.20 p275
	25				2500	VD4/P 17.25.25 p275
	31.5				2500	VD4/P 17.25.32 p275
	40				2500	VD4/P 17.25.40 p275
	50				2500	VD4/P 17.25.50 p275
	20				3150 (1)	VD4/W 17.32.20 p275
	25				3150 (1)	VD4/W 17.32.25 p275
	31.5				3150 (1)	VD4/W 17.32.32 p275
	40				3150 (1)	VD4/W 17.32.40 p275
	50				3150 (1)	VD4/W 17.32.50 p275

W = Enclosure width.  
P = Pole horizontal centre distance.  
u/l = Distance between bottom and top terminal.  
ø = Diameter of the isolating contact.  
(1) Up to 4000 A with forced ventilation.



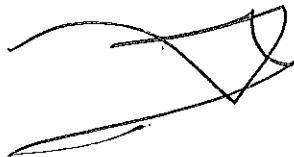

VD4 withdrawable circuit-breaker (24 kV)

Ur	Isc	Rated uninterrupted current (40 °C) [A]		Circuit-breaker type
		W=800	W=1000	
kV	kA	P=210	P=275	
		u/l=310	u/l=310	
		ø=35	ø=79	
24	16	630		VD4/P 24.06.16 p210
	20	630		VD4/P 24.06.20 p210
	25	630		VD4/P 24.06.25 p210
	16	1250		VD4/P 24.12.16 p210
	20	1250		VD4/P 24.12.20 p210
	25	1250		VD4/P 24.12.25 p210
	31.5	1250		VD4/P 24.12.32 p210
	16		1600	VD4/P 24.16.16 p275
	20		1600	VD4/P 24.16.20 p275
	25		1600	VD4/P 24.16.25 p275
	31.5		1600	VD4/P 24.16.32 p275
	16		2000	VD4/P 24.20.16 p275
	20		2000	VD4/P 24.20.20 p275
	25		2000	VD4/P 24.20.25 p275
	31.5		2000	VD4/P 24.20.32 p275
	16		2300 <sup>(1)</sup>	VD4/P 24.25.16 p275
	20		2300 <sup>(1)</sup>	VD4/P 24.25.20 p275
	25		2300 <sup>(1)</sup>	VD4/P 24.25.25 p275
	31.5		2300 <sup>(1)</sup>	VD4/P 24.25.32 p275

W = Enclosure width.  
P = Pole horizontal centre distance.  
u/l = Distance between bottom and top terminal.  
ø = Diameter of the isolating contact.  
(1) Up to 2500 A rated current guaranteed with forced ventilation.

Standard fittings of withdrawable circuit-breakers for PowerCube modules

The basic versions of the withdrawable circuit-breakers are always three-pole and fitted with:

- EL type manual operating mechanism
- mechanical signalling device for closing springs charged/discharged
- mechanical signalling device for circuit-breaker open/closed
- closing pushbutton
- opening pushbutton
- operation counter
- set of ten circuit-breaker open/closed auxiliary contacts  
Note: with the group of ten auxiliary contacts supplied as standard and the maximum number of electrical applications, three break contacts (signalling circuit-breaker open) and four make contacts (signalling circuit-breaker closed) are available.
- lever built into operating mechanism for linear loading of closing spring
- isolating contacts
- cord with connector (plug only) for auxiliary circuits, with striker pin which does not allow the plug to be inserted into the socket if the rated current of the circuit-breaker is different from the rated current of the panel

- racking-in/out lever (the quantity must be defined according to the number of pieces of apparatus ordered)
- locking electromagnet in the truck. This prevents the circuit-breaker being racked into the panel with the auxiliary circuits disconnected (plug not inserted in the socket).
- door interlock (compulsory for ABB switchgear); this device prevents racking the circuit-breaker into the switchgear when the switchgear door is open.

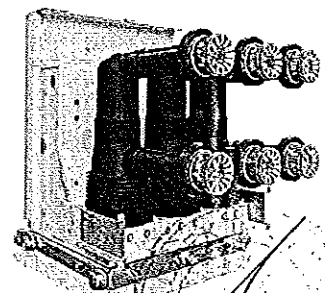
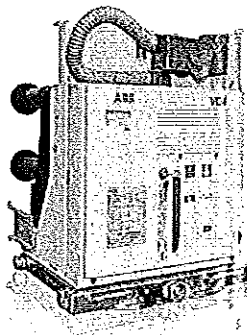

VD4 with poles in polyamide

## 2. Selection and ordering Withdrawable circuit-breakers

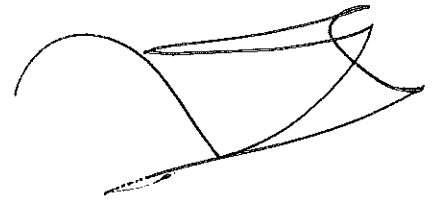

Withdrawable circuit-breakers for ZS8.4  
type switchgear (12 - 17.5 - 24 kV)

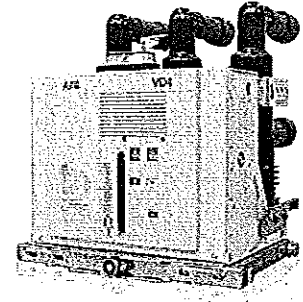

Circuit-breaker		VD4/Z8					
	Panel without partitions	•					
	Panel with partitions	—					
	Preussen Elektra - EON <sup>(2)</sup>	—					
	Width [mm]	650	650	650	650	800	800
	Depth [mm]	1000	1000	1000	1000	1200	1200
Standards	IEC 62271-100	•					
Rated voltage	Ur [kV]	12	12	17.5	17.5	24	24
Rated insulation voltage	Us [kV]	12	12	17.5	17.5	24	24
Withstand voltage at 50 Hz	Ud (1 min) [kV]	28	28	38	38	50	50
Impulse withstand voltage	Up [kV]	75	75	95	95	125	125
Rated frequency	fr [Hz]	50-60					
Rated normal current (40 °C) <sup>(1)</sup>	Ir [A]	630	1250	630	1250	630	1250
Rated breaking capacity (rated symmetrical short-circuit current)	Isc [kA]	—	—	—	—	16	16
		20	20	20	20	20	20
Rated short-time withstand current(3 s)	Ik [kA]	—	—	—	—	16	16
		20	20	20	20	20	20
Making capacity	Ip [kA]	—	—	—	—	40	40
		50	50	50	50	50	50
		63	63	63	63	63	63
Operation sequence	[O-0.3s-CO-15s-CO]	•					
Opening time	[ms]	33...60					
Arcing time	[ms]	10...15					
Total breaking time	[ms]	43...75					
Closing time	[ms]	30...60					
Maximum overall dimensions	H [mm]	579	579	579	579	680	680
	W [mm]	503	503	503	503	653	653
	D [mm]	548	548	548	548	646	646
	Pole distance P [mm]	150	150	150	150	210	210
Weight	[kg]	116	116	116	116	140	140
Standardised table of dimensions	1VCD	000092	000137	000137	000137	000089	000138
Operating temperature	[°C]	- 5 ... + 40					
Tropicalisation	IEC 60068-2-30	•					
	IEC 60721-2-1	•					
Electromagnetic compatibility	IEC 62271-1	•					

(1) Rated current guaranteed with circuit-breaker installed in switchgear with 40 °C ambient temperature.

(2) Special type with device for charging the closing spring by means of a rotary handle outside the operating mechanism.

VD4/ZT8						VD4/ZS8			
—						—			
•						—			
—						•			
650	650	650	650	800	800	650	650	800	800
1200	1200	1200	1200	1200	1200	1200	1200	1200	1200
•						•			
12	12	17.5	17.5	24	24	12	12	24	24
12	12	17.5	17.5	24	24	12	12	24	24
28	28	38	38	50	50	28	28	50	50
75	75	95	95	125	125	75	75	125	125
50-60						50-60			
630	1250	630	1250	630	1250	630	1250	630	1250
—	—	—	—	16	16	—	—	16	16
20	20	20	20	20	20	20	20	20	20
25	25	25	25	25	25	25	25	25	25
—	—	—	—	16	16	—	—	16	16
20	20	20	20	20	20	20	20	20	20
25	25	25	25	25	25	25	25	25	25
—	—	—	—	40	40	—	—	40	40
50	50	50	50	50	50	50	50	50	50
63	63	63	63	63	63	63	63	63	63
•						•			
33...60						33...60			
10...15						10...15			
43...75						43...75			
30...60						30...60			
579	579	579	579	680	680	579	579	680	680
503	503	503	503	653	653	503	503	653	653
638	638	638	638	646	646	638	638	646	646
150	150	150	150	210	210	150	150	210	210
116	116	116	116	140	140	116	116	140	140
000093	000134	000134	000134	000090	000136	000091	000133	000088	000135
- 5 ... + 40						- 5 ... + 40			
•						•			
•						•			
•						•			
•						•			

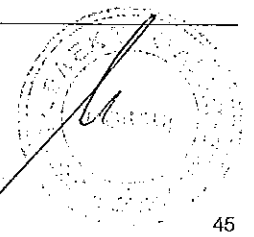

## 2. Selection and ordering Withdrawable circuit-breakers

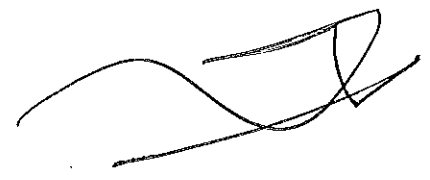

VD4/ZS8 - VD4/ZT8 - VD4/Z8 withdrawable circuit-breaker for ZS8.4 switchgear

Ur	Isc	Rated uninterrupted current (40°C) [A]						Circuit-breaker type	
		Panel without partition		Panel with partition		Special panel EON			
		W = 650	W = 800	W = 650	W = 800	W = 650	W = 800		
		P = 150	P = 210	P = 150	P = 210	P = 150	P = 210		
kV	kA	u/l = 205	u/l = 310	u/l = 205	u/l = 310	u/l = 205	u/l = 310		
		ø = 35	ø = 35	ø = 35	ø = 35	ø = 35	ø = 35		
		20	630					VD4/Z8 12.06.20 p150	
		25	630					VD4/Z8 12.06.25 p150	
12	20	1250						VD4/Z8 12.12.20 p150	
	25	1250						VD4/Z8 12.12.25 p150	
	20			630				VD4/ZT8 12.06.20 p150	
	25			630				VD4/ZT8 12.06.25 p150	
	20			1250				VD4/ZT8 12.12.20 p150	
	25			1250				VD4/ZT8 12.12.25 p150	
	20					630		VD4/ZS8 12.06.20 p150	
	25					630		VD4/ZS8 12.06.25 p150	
	20					1250		VD4/ZS8 12.12.20 p150	
	25					1250		VD4/ZS8 12.12.25 p150	
	17.5	20	630						VD4/Z8 17.06.20 p150
		25	630						VD4/Z8 17.06.25 p150
20		1250						VD4/Z8 17.12.20 p150	
25		1250						VD4/Z8 17.12.25 p150	
20				630				VD4/ZT8 17.06.20 p150	
25				630				VD4/ZT8 17.06.25 p150	
20				1250				VD4/ZT8 17.12.20 p150	
25				1250				VD4/ZT8 17.12.25 p150	
24	16		630					VD4/Z8 24.06.16 p210	
	20		630					VD4/Z8 24.06.20 p210	
	25		630					VD4/Z8 24.06.25 p210	
	16		1250					VD4/Z8 24.12.16 p210	
	20		1250					VD4/Z8 24.12.20 p210	
	25		1250					VD4/Z8 24.12.25 p210	
	16				630			VD4/ZT8 24.06.16 p210	
	20				630			VD4/ZT8 24.06.20 p210	
	25				630			VD4/ZT8 24.06.25 p210	
	16				1250			VD4/ZT8 24.12.16 p210	
	20				1250			VD4/ZT8 24.12.20 p210	
	25				1250			VD4/ZT8 24.12.25 p210	
	16						630	VD4/ZS8 24.06.16 p210	
	20						630	VD4/ZS8 24.06.20 p210	
	25						630	VD4/ZS8 24.06.25 p210	
	16						1250	VD4/ZS8 24.12.16 p210	
20						1250	VD4/ZS8 24.12.20 p210		
25						1250	VD4/ZS8 24.12.25 p210		

W = Switchboard width.  
P = Pole horizontal centre distance.  
u/l = Distance between bottom and top terminal.  
ø = Diameter of the isolating contact.



**Standard fittings of withdrawable circuit-breakers for ZS8.4 switchgear**

The basic versions of the withdrawable circuit-breakers are three-pole and fitted with:

- EL type manual operating mechanism
- mechanical signalling device for closing springs charged/discharged
- mechanical signalling device for circuit-breaker open/closed
- closing pushbutton
- opening pushbutton
- operation counter
- set of ten circuit-breaker open/closed auxiliary contacts  
Note: with the group of ten auxiliary contacts supplied as standard and the maximum number of electrical applications, three break contacts (signalling circuit-breaker open) and four make contacts (signalling circuit-breaker closed) are available.
- lever built into operating mechanism for linear loading of closing spring for VD4/Z8 and VD4/ZT8, external with crank operation for VD4/ZS8
- racking in/out lever (the quantity must be defined according to the number of pieces of apparatus ordered)

**VD4/ZS8**

- device for closing spring charging, with the door closed, by means of a removable rotary crank handle outside the operating mechanism and the switchgear
- Harting 64-pin socket with mechanical interlock which prevents traverse of the circuit-breaker when the plug is not inserted in the socket
- interlock with the door which prevents the spring charging lever when the circuit-breaker is closed
- interlock with the door and Harting 64 pin socket which prevents door closing when the plug is not inserted in the socket.

**VD4/Z8 - VD4/ZT8**

- Harting 64-pin socket with mechanical interlock which prevents traverse of the circuit-breaker when the plug is not inserted in the socket.

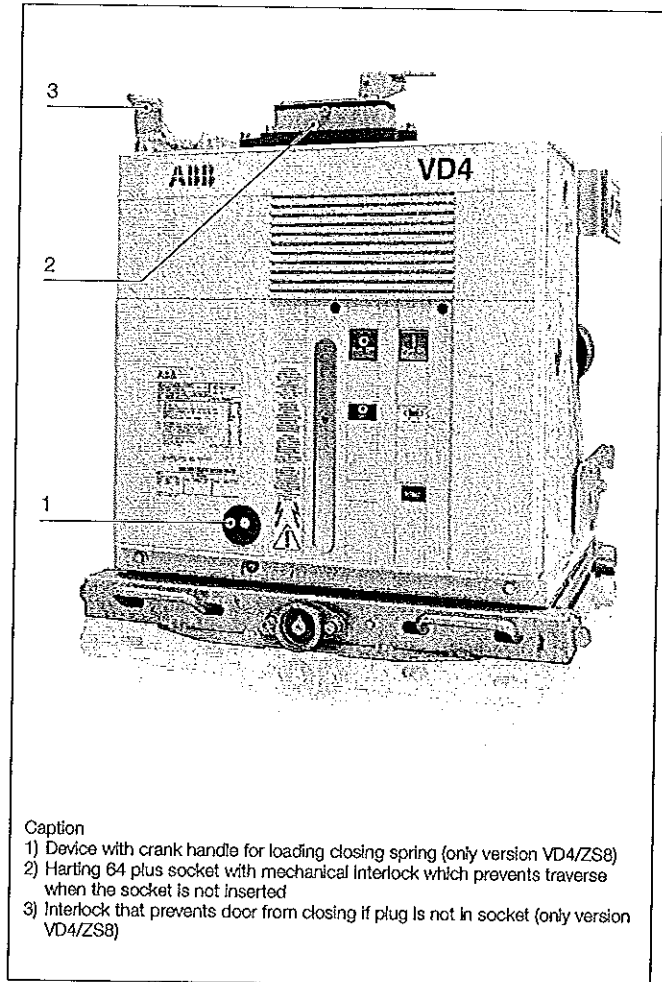

## 2. Selection and ordering Withdrawable circuit-breakers

Withdrawable circuit-breakers for UniSwitch switchgear (CBW type unit) and UniMix switchgear (P1/E type unit) (24 kV)

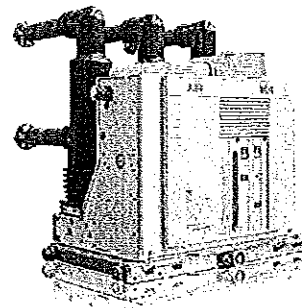

Circuit-breaker	VD4/US 24 <sup>(3)</sup>		VD4/US 24 <sup>(4)</sup>	
	UniSwitch (unit CBW type)	UniMix (unit P1/E type)		
Standards	IEC 62271-100			
Rated voltage	Ur [kV]	24	24	24
Rated insulation voltage	Us [kV]	24	24	24
Withstand voltage at 50 Hz	Ud (1 min) [kV]	50	50	50
Impulse withstand voltage	Up [kV]	125	125	125
Rated frequency	fr [Hz]	50-60	50-60	50-60
Rated normal current (40 °C) <sup>(1)</sup>	Ir [A]	630	1250	630
Rated breaking capacity (rated symmetrical short-circuit current)	Isc [kA]	16 (20) <sup>(5)</sup>	16 (25) <sup>(5)</sup>	16
		20 (25) <sup>(5)</sup>	20 (25) <sup>(5)</sup>	20
Rated short-time withstand current (3 s) <sup>(2)</sup>	Ik [kA]	16 (20) <sup>(5)</sup>	16 (25) <sup>(5)</sup>	16
		20 (25) <sup>(5)</sup>	20 (25) <sup>(5)</sup>	20
Making capacity	Ip [kA]	40 (50) <sup>(5)</sup>	40 (50) <sup>(5)</sup>	40
		50 (63) <sup>(5)</sup>	50 (63) <sup>(5)</sup>	50
Operation sequence	[O - 0.3 s - CO - 15 s - CO]			
Opening time	[ms]	33 ... 60	33 ... 60	33 ... 60
Arcing time	[ms]	10 ... 15	10 ... 15	10 ... 15
Total breaking time	[ms]	43 ... 75	43 ... 75	43 ... 75
Closing time	[ms]	30 ... 60	30 ... 60	30 ... 60
Maximum overall dimensions	H [mm]	680	680	680
	W [mm]	653	653	653
	D [mm]	742	742	742
	Pole distance P [mm]	210	210	210
Weight	[kg]	125	125	125
Standardised table of dimensions	1VCD	000047	000047	000047
Operating temperature	[°C]	- 5 ... + 40	- 5 ... + 40	- 5 ... + 40
Tropicalization	IEC: 60068-2-30, 60721-2-1			
Electromagnetic compatibility	IEC 62271			

(1) Rated current guaranteed with withdrawable circuit-breaker installed in switchgear with 40 °C ambient temperature

(2) The value and duration of the rated short-time withstand current depends on the switchgear. See the specific catalogues of the UniSwitch and UniMix switchgear

(3) The top shutter activation wheels of the UniSwitch switchgear (CBW unit) are mounted and adjusted by the manufacturer of the UniSwitch switchgear

(4) The top shutter activation wheels of the UniMix switchgear (P1/E unit) are available on request

(5) The values in brackets refer to the 12 kV rated voltage.

Withdrawable c.-breaker for UniSwitch switchgear (CBW type unit) and UniMix switchgear (P1/E type unit)

Ur	Isc	Rated uninterrupted current (40 °C) [A]		Circuit-breaker type
		UniSwitch CBW	UniMix P1/E	
kV	kA	P=210	P=210	
		u/l=310	u/l=310	
		ø=35	ø=79	
24	16	630 <sup>(1)</sup>	630	VD4/US 24.06.16 p210
	20	630 <sup>(1)</sup>	630	VD4/US 24.06.20 p210
	25	—	630	VD4/US 24.06.25 p210
	16	1250 <sup>(1)</sup>	1250	VD4/US 24.12.16 p210
	20	1250 <sup>(1)</sup>	1250	VD4/US 24.12.20 p210
	25	—	1250	VD4/US 24.12.25 p210

(1) Isc 25 kA at 12 kV.

P = Horizontal centre distance between poles.

u/l = Distance between top and bottom terminal.

ø = Diameter of the isolating contacts.

### Standard fittings of withdrawable circuit-breakers for UniSwitch and UniMix switchgear

The basic versions of the withdrawable circuit-breakers are three-pole and fitted with:

- EL type manual operating mechanism
- mechanical signalling device for closing springs charged/discharged
- mechanical signalling device for circuit-breaker open/closed
- closing pushbutton
- opening pushbutton
- operation counter
- set of ten circuit-breaker open/closed auxiliary contacts  
Note: with the group of ten auxiliary contacts supplied as standard and the maximum number of electrical applications, three break contacts (signalling circuit-breaker open) and four make contacts (signalling circuit-breaker closed) are available.
- lever built into operating mechanism for linear loading of closing spring
- isolating contacts
- cord with connector (plug only) for auxiliary circuits, with striker pin which does not allow the plug to be inserted into the socket if the rated current of the circuit-breaker is different from the rated current of the panel
- racking-in/out lever (the quantity must be defined according to the number of pieces of apparatus ordered)
- locking electromagnet in the truck. This prevents the circuit-breaker being racked into the panel with the auxiliary circuits disconnected (plug not inserted in the socket).



## 2. Selection and ordering Withdrawable circuit-breakers

General characteristics of withdrawable circuit-breakers for UniSec switchgear (units WBC and WBS)

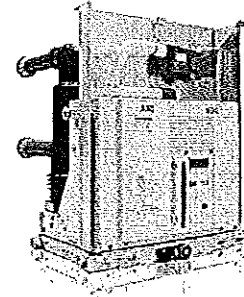

Circuit-breaker		VD4/SEC	VD4/P 12		VD4/P 17		
standards	IEC 62271-100	•	•	•	•	•	
Rated voltage	Ur [kV]	24	12		17.5		
Rated insulation voltage	Us [kV]	24	12		17.5		
Withstand voltage at 50 Hz	Ud (1 min) [kV]	50	28		38		
Impulse withstand voltage	Up [kV]	125	75		95		
Rated frequency	fr [Hz]	50-60	50-60		50-60		
Rated normal current (40 °C) <sup>(1)</sup>	Ir [A]	630 - 1250	630	1250	630	1250	
		16	16	16	16	16	
Rated breaking capacity (rated symmetrical short-circuit current)	Isc [kA]	20	20	20	20	20	
		25	25	25	25	25	
Rated short-time withstand current (3 s)	Ik [kA]	16	16	16	16	16	
		20	20	20	20	20	
Making capacity	Ip [kA]	25	25	25	25	25	
		40	40	40	40	40	
Operation sequence	[O - 0.3 s - CO - 15 s - CO]	•	•	•	•	•	
		•	•	•	•	•	
Opening time	[ms]	33 ... 60	33 ... 60				
Arcing time	[ms]	10 ... 15	10 ... 15				
Total breaking time	[ms]	43 ... 75	43 ... 75				
Closing time	[ms]	30 ... 60	30 ... 60				
Maximum overall dimensions		H [mm]	743	628	628	632	632
		W [mm]	653	503	503	503	503
		D [mm]	742	662	662	664	664
		Pole distance P [mm]	210	150	150	150	150
Weight	[kg]	133	116	116	116	116	
Standardised table of dimensions	1VCD	000190	7412 <sup>(2)</sup>	7412 <sup>(2)</sup>	7412 <sup>(2)</sup>	7412 <sup>(2)</sup>	
Operating temperature	[°C]	- 5 ... + 40					
Tropicalization	IEC: 60068-2-30, 60721-2-1	•	•				
Electromagnetic compatibility	IEC 62271	•	•				

(1) Rated current guaranteed with withdrawable circuit-breaker installed in switchgear with 40 °C ambient temperature.

(2) Poles in polyamide.

Withdrawable circuit-breaker for UniSec switchgear

Ur	Isc	Rated uninterrupted current (40 °C) [A]			Circuit-breaker type
		P=150 u/l=205 ø=35	P=150 u/l=205 ø=35	P=210 u/l=310 ø=79	
12	16	630			VD4/P 12.06.16 p150
	20	630			VD4/P 12.06.20 p150
	25	630			VD4/P 12.06.25 p150
	16	1250			VD4/P 12.12.16 p150
	20	1250			VD4/P 12.12.20 p150
	25	1250			VD4/P 12.12.25 p150
17	16		630		VD4/P 17.06.16 p150
	20		630		VD4/P 17.06.20 p150
	25		630		VD4/P 17.06.25 p150
	16		1250		VD4/P 17.12.16 p150
	20		1250		VD4/P 17.12.20 p150
	25		1250		VD4/P 17.12.25 p150
24	16			630	VD4/SEC 24.06.16 p210
	20			630	VD4/SEC 24.06.20 p210
	25			630	VD4/SEC 24.06.25 p210
	16			1250	VD4/SEC 24.12.16 p210
	20			1250	VD4/SEC 24.12.20 p210
	25			1250	VD4/SEC 24.12.25 p210

P = Horizontal centre distance between poles.  
u/l = Distance between top and bottom terminal.  
ø = Diameter of the isolating contacts.

Standard fittings of withdrawable circuit-breakers for UniSec

The basic versions of the withdrawable circuit-breakers are three-pole and fitted with:

- EL type manual operating mechanism
- mechanical signalling device for closing springs charged/ discharged
- mechanical signalling device for circuit-breaker open/closed
- closing pushbutton
- opening pushbutton
- operation counter
- set of ten circuit-breaker open/closed auxiliary contacts  
Note: with the group of ten auxiliary contacts supplied as standard and the maximum number of electrical applications, three break contacts (signalling circuit-breaker open) and four make contacts (signalling circuit-breaker closed) are available.
- lever built into operating mechanism for linear loading of closing spring
- isolating contacts
- cord with connector (plug only) for auxiliary circuits, with striker pin which does not allow the plug to be inserted into the socket if the rated current of the circuit-breaker is different from the rated current of the panel
- racking-in/out lever (the quantity must be defined according to the number of pieces of apparatus ordered)

## 2. Selection and ordering Optional accessories

The accessories identified with the same number are alternative to each other.

### 1 Shunt opening release (-MBO1)

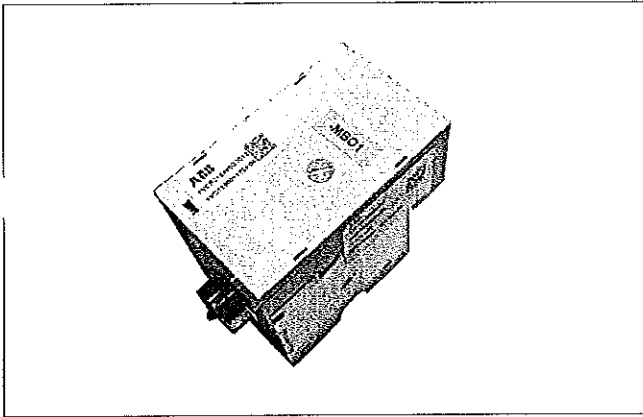

Allows opening command of apparatus to be enabled by remote control.

This release is suitable for both instantaneous and permanent duty. However, an auxiliary contact -BGB1 de-energizes it after circuit-breaker has opened. In the case of instantaneous service, the current impulse must last at least 100 ms.

This release can be controlled by the following devices: coil continuity control (CCC), opening circuit supervision (TCS)(\*) or the ABB STU functionality control device (see accessory 21, supplied on request).

Characteristics	
Un	24-30-48-60-110...132-220...250 V DC
Un	48-60-110...127-220...250 V AC 50-60 Hz
Operating limits	65 ... 120% Un
Inrush power (Ps)	60...100 W / VA
Potenza di mantenimento (Pc)	1.5 W
Electronics self-consumption (no coil supplied); value independent of voltage applied	1.5 mA
Opening time	33...60 ms
Insulation voltage	2000 V 50 Hz (for 1 min)

(\*) The minimum current that the relay with TCS function (used for monitoring coil continuity) detects as a condition denoting that the trip circuit is operating correctly (specified for each relay in the relative manual), must be sensibly higher than the current consumption of the actual coil (~1.5 mA).  
If this fails to occur, always add, in parallel to the TCS, a circuit able to absorb sufficient current to compensate the gap while preventing the total current in the TCS circuit from rising above the maximum threshold (Itcs < 10 mA for High Voltage coils - from 110V to 250V, and Itcs < 50 mA for Low Voltage coils from 24 V to 60 V).  
A simple resistor can be sized for the purpose, depending on the parameters of the TCS and the auxiliary voltage range used.

### 2 Additional shunt opening release (-MBO2)

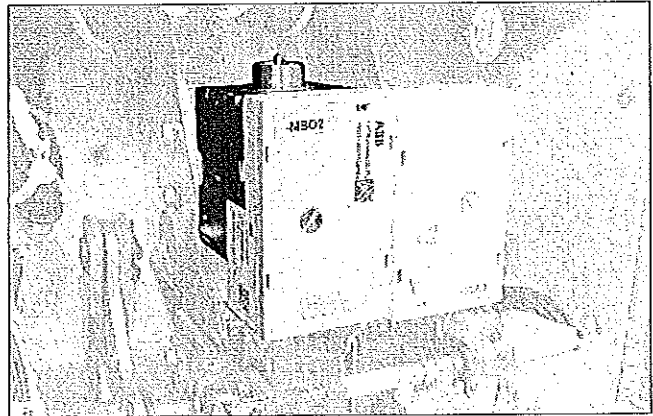

Similarly to shunt opening release -MBO1, this allows the opening command of the apparatus to be transmitted by remote control. It can be powered by the same circuit as main shunt opening release -MBO1 or by a circuit that is completely separate from release -MBO1.

This release is suitable for both instantaneous and permanent duty. However, an auxiliary contact -BGB1 de-energizes it after the circuit-breaker has opened.

To guarantee the release action, the current impulse must last at least 100 ms.

Continuity functionality can be checked with a continuity control device (CCC), opening circuit supervision (TCS)(\*) or the STU functionality control device (see accessory 21, supplied on request).

-MBO2 has the same electrical and operating characteristics as release -MBO1.

(

(

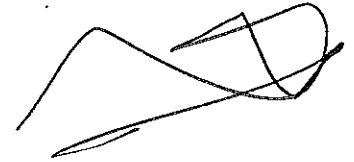

### 3 Opening solenoid (-MO3)

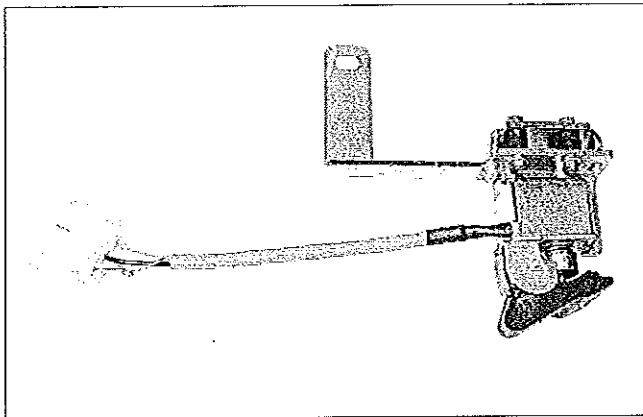

The opening solenoid (-MO3) is a special release with demagnetisation to be combined with an overcurrent protection relay of the self-supplied type. It is located in the operating mechanism (in the left side piece) and is not alternative to the additional shunt opening release (-MO2). It is not available for 40 and 50 kA circuit-breakers. Should the application of this accessory be required, specify the request at the time of order since subsequent application by the customer is not possible.

Note: for combination with the protection relays, please ask for the document: Data sheet 1VCD600854.

- The opening solenoid (-MBO3) is available in two versions:
- For DC (release by discharging energy stored in protection relay against overcurrent of the self-supplied type)
  - For AC (release by means of the energy supplied by an adder transformer on the secondaries of the protection current transformers (the TA is at customer's charge))

(\*) The minimum current that the relay with TCS function (used for monitoring coil continuity) detects as a condition denoting that the trip circuit is operating correctly (specified for each relay in the relative manual), must be sensibly higher than the current consumption of the actual coil (~1.5 mA). If this fails to occur, always add, in parallel to the TCS, a circuit able to absorb sufficient current to compensate the gap while preventing the total current in the TCS circuit from rising above the maximum threshold (Itcs < 10 mA for High Voltage coils - from 110V to 250V, and Itcs < 50 mA for Low Voltage coils from 24 V to 60 V). A simple resistor can be sized for the purpose, depending on the parameters of the TCS and the auxiliary voltage range used.

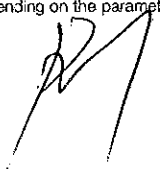

### 4 Shunt closing release (-MC)

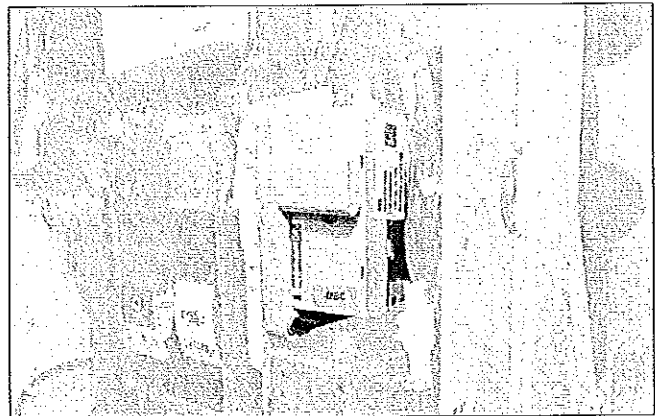

Allows closing command of apparatus to be transmitted by remote control.

This release is suitable for both instantaneous and permanent duty. An auxiliary contact that de-energizes it after the circuit-breaker has closed is not envisaged.

The permanently supplied release provides the electrical anti-pumping function with both electrical opening and re-closing commands maintained. To guarantee the closing action, the current impulse must last at least 100 ms.

If there is the same supply voltage for shunt closing release -MBC and under-voltage release -MBU and the circuit-breaker must close automatically when auxiliary voltage returns, there must be a delay of at least 50 ms between under-voltage release energizing and energizing of the shunt closing release to allow the closing operation to take place. Continuity functionality can be checked with a continuity control device (CCC), opening circuit supervision (TCS)(\*) or the STU functionality control device (see accessory 21, supplied on request).

Characteristics	
Un	24-30-48-60-110...132-220...250 V DC
Un	48-60-110...127-220...250 V AC 50-60 Hz
Operating limits	65 ... 120% Un
Inrush power (Ps)	60... 100 W / VA
Continuous power consumption (Pc)	1.5 W
Electronics self-consumption (no coil supplied; value independent of voltage applied)	1.5 mA
Opening time	33...60 ms
Insulation voltage	2000 V 50 Hz (for 1 min)

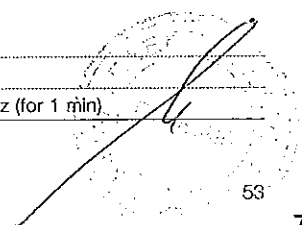

## 2. Selection and ordering Optional accessories

### 5 Undervoltage release (-MBU)

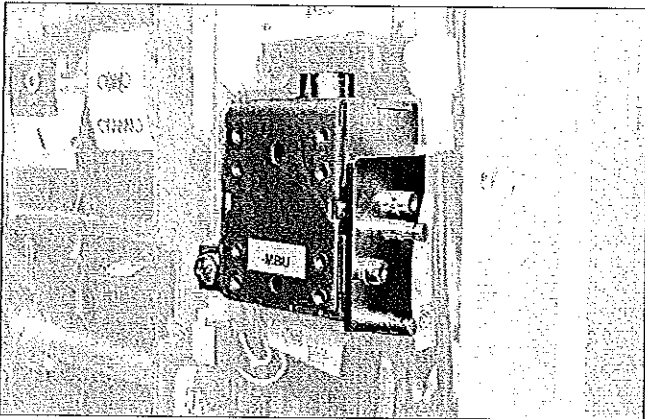

The undervoltage release opens the circuit-breaker when there is a sensible reduction or lack of the voltage that powers it. The circuit-breaker can only close when the release is energized (the closing lock is obtained mechanically). It can be used for remote release (by means of a pushbutton of the normally closed type), for locking on automatic closing/opening in the absence of voltage in the auxiliary circuits. Supplied by means of the secondary output of a voltage transformer, it provides locking upon automatic closing/opening in the absence of voltage in the Medium Voltage main circuit.

If there is the same supply voltage for shunt closing release -MBC and under-voltage release -MBU and the circuit-breaker must close automatically when auxiliary voltage returns, there must be a delay of at least 50 ms between under-voltage release energizing and energizing of the shunt closing release to allow the closing operation to take place.

The undervoltage release is available in the following versions:

- 5A** Undervoltage release (with supply shunted from a transformer on the supply side of the circuit-breaker or from an auxiliary power supply, regardless of the state in which the circuit-breaker is to be found).
- 5B** Undervoltage release with -KFT electronic time-lag device (0.5 - 1 - 1.5 - 2 - 3 s) (with power supply as indicated for 5A); this device is supplied with a 0.5 s setting (the adjustments are described in the Circuit diagrams chapter)

Characteristics	
Un	24-30-48-60-110...132-220...250 V DC
Un	48-60-110...127-220...250 V AC 50-60 Hz
Operating limits	- circuit-breaker opening: 35-70% Un - circuit-breaker closing: 85-110% Un
Inrush power (Ps)	150 W / VA
Continuous power consumption (Pc)	1.55 W
Electronics self-consumption (no coil supplied); value independent of voltage applied	1.5 mA
Opening time	60...80 ms
Insulation voltage	2000 V 50 Hz (for 1 min)

#### Note

As an alternative to the undervoltage release, an additional shunt opening release (-MBO4) with the same electrical and operating specifications as shunt opening release (-MBO1) can be installed on request (only for circuit-breakers 12..17.5 kV up to 40 kA and 24 kV up to 31.5 kA). **Warning!** Since installation of the additional shunt opening release (-MBO4) requires a special mounting plate for releases, ask for application (-MBO4) when ordering and not after delivery.

5a Electronic time delay device (-KFT)

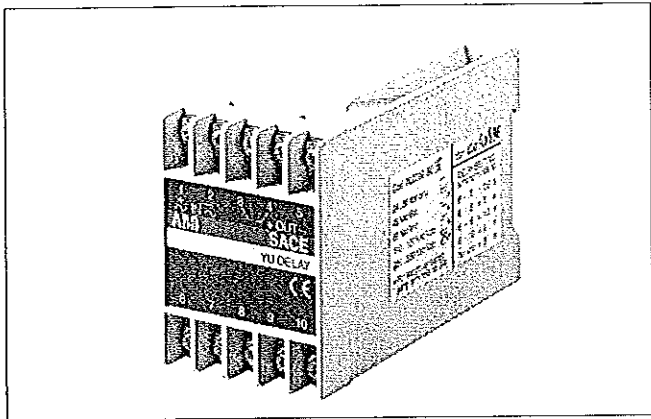

The electronic time delay device must be mounted externally in relation to the circuit-breaker. It allows release trip delay with established and adjustable times.

The use of the undervoltage release is recommended in order to prevent trips when the power supply network of the release may be subject to cuts or voltage drops of short duration. If it is not supplied, circuit-breaker closing is disabled.

The time delay device must be combined with an undervoltage release for d.c.

Rated voltage of the undervoltage release must be within the selected range of working of the time-delay device.

Characteristics of the time-delay device

Un	24...30 - 48 - 60 - 110...127 - 220...250 V-
Un	48 - 60 - 110...127 - 220...240 - V- 50/60 Hz
Adjustable opening time (release + time delay device): 0.5-1-1.5-2-3 sec	

6 Undervoltage release mechanical override

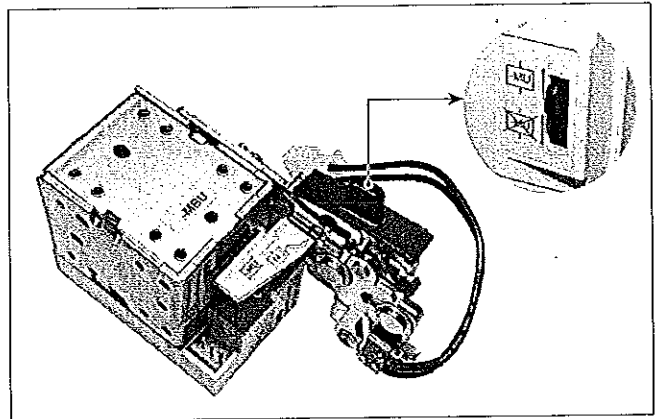

This is a mechanical device which allows the undervoltage release trip to be temporarily excluded. It is always fitted with electrical signalling.

Should the application of this accessory be required, specify the request at the time of order since subsequent application by the customer is not possible.

## 2. Selection and ordering Optional accessories

### 7a Auxiliary contacts of the circuit-breaker (-BGB1) for 12 to 24 kV versions

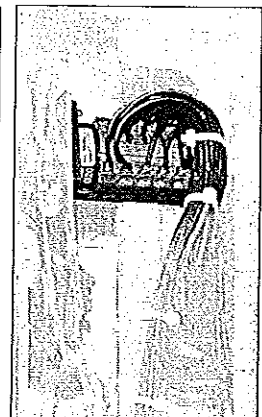
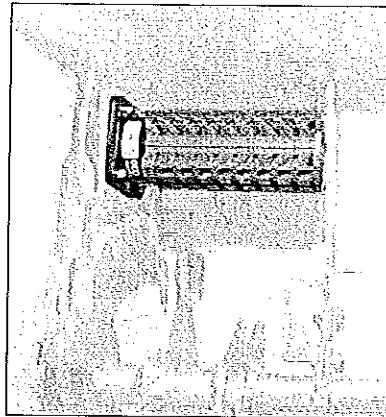
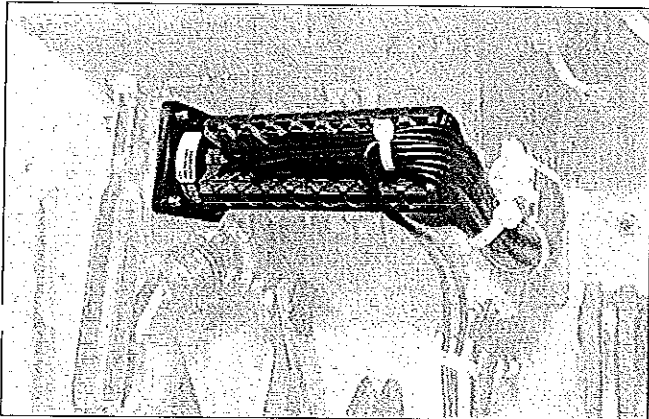

Electrical signalling of circuit-breaker open/closed can be obtained with a group of 10, 16 or 20 auxiliary contacts for the fixed version and 10 or 16 auxiliary contacts for the withdrawable version. The standard equipment comprises 10 auxiliary contacts.

#### Note

The following are available using the standard group of ten auxiliary contacts and the maximum number of electrical accessories:

- for fixed circuit-breakers: three closing contacts "a" for signalling circuit-breaker open and five opening contacts "b" for signalling circuit-breaker closed;
  - for withdrawable circuit-breakers: three closing contacts "a" for signalling circuit-breaker open and four opening contacts "b" for signalling circuit-breaker closed;
- Circuit-breakers in the fixed version are available with two finishing accessories (to be specified when ordering):
- non-wired auxiliary contacts; wiring to the terminals of the contacts is at the customer's charge (photo below left; the terminal box to which the other electrical accessories are wired is at the top); ask for instructions 1VCD601204 (available in the main languages) which describe how to remove, wire auxiliary contacts more easily and fit auxiliary contacts unit back into its housing;
  - auxiliary contacts already wired to the terminal box (see photo at top right)

Consult circuit diagrams 1VCD400151 for fixed circuit-breakers and 1VCD400155 for withdrawable circuit-breakers.

**Note:** The main shunt opening release and/or the additional shunt opening release use 1 and/or 2 closing contacts "a", thereby reducing the number of auxiliary contacts available. Always check the maximum number of contacts available with non-standard equipment.

The new diagrams are interchangeable with the existing ones, with the following exceptions:

- diagram 1VCD400151 (substitutes 1VCD400046 and 1VCD400099)
- fig. 34 on the previous diagrams is represented by fig. 31 + fig. 32 on the new diagram;
- fig. 33 and fig. 35 on the previous diagrams are not available with the new layout
- diagram 1VCD400155 (substitutes 1VCD400047)



Auxiliary contacts –BGB1 conform to the following standards/ regulations/directives:

- IEC 62271-100
- IEEE C37.54
- EN 61373 cat.1 class B / impact and vibration test
- Germanish Loyd regulation / vibrations envisaged by the shipping registers
- UL 508
- EN 60947 (DC-21A DC-22A DC-23A AC-21A)
- RoHS Directive

**General characteristics**

Insulation voltage to standard VDE 0110, Group C	660 V AC 800 V DC
Rated voltage	24 V ... 660 V
Test voltage	2 kV for 1 min
Maximum rated current	10 A - 50/60 Hz
Breaking capacity	Class 1 (IEC 62271-1)
Number of contacts	5
Groups of contacts	10 / 16 / 20
Contact travel	90°
Actuating force	0.66 Nm
Resistance	<6.5 mΩ
Storage temperature	-30 °C ... +120 °C
Operating temperature	-20 °C ... +70 °C (-30° ref. ANSI 37.09)
Contact overtemperature	10 K
Mechanical life	30,000 mechanical operations
Protection class	IP20
Cable section	1 mm <sup>2</sup>

**Electrical characteristics (according to IEC 60947)**

Rated current Un	Breaking capacity (10000 interruptions)	
220 V AC Cosφ = 0.70	20 A	
220 V DC Cosφ = 0.45	10 A	
24 V DC	1 ms	12 A
	15 ms	9 A
	50 ms	6 A
60 V DC	1 ms	10 A
	15 ms	6 A
	50 ms	4,6 A
110 V DC	1 ms	7 A
	15 ms	4.5 A
	50 ms	3.5 A
220 V DC	1 ms	2 A
	15 ms	1.7 A
	50 ms	1.5 A
250 V DC	1 ms	2 A
	15 ms	1,4 A
	50 ms	1.2 A

**Electrical characteristics (according to IEC 62271-100 class 1)**

Rated current Un	Breaking capacity
24 Vcc 20 ms	18,8 mA
60 Vcc 20 ms	7,4 mA
110 Vcc 20 ms	4,2 mA
250 Vcc 20 ms	1,8 mA

## 2.) Selection and ordering Optional accessories

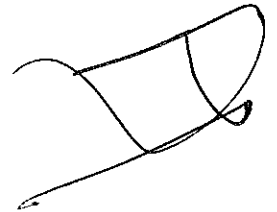

### 7b Circuit-breaker auxiliary contacts (-BGB1, -BGB2, -BGB3) for 36 kV version

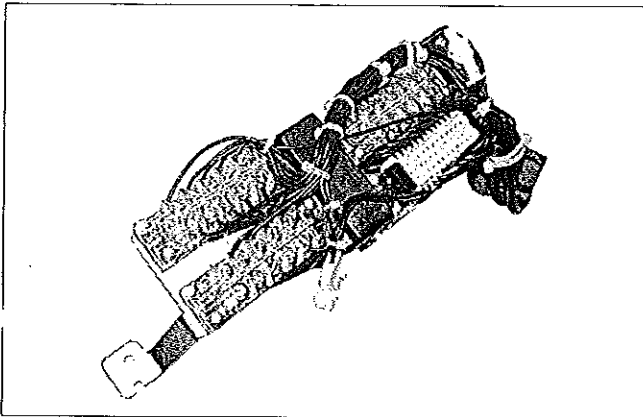

Electrical signalling of circuit-breaker open/closed can be provided with a set of 15 auxiliary contacts as an alternative to the 10 provided as standard.

Consult the following circuit diagrams for VD4 36 kV series with "7b" auxiliary contacts:

- for fixed circuit-breakers: 1VCD400236
- for withdrawable circuit-breakers: 1VCD400237

#### Note

With the group of ten auxiliary contacts supplied as standard and the maximum number of electrical applications, three break contacts (signalling circuit-breaker open) and five make contacts (signalling circuit-breaker closed) are available.

With the group of 15 auxiliary contacts, according to the electrical applications required, the following are available:

- for fixed circuit-breakers: thirteen auxiliary contacts, differently divided between break contacts and make contacts according to the figure selected of the electrical diagram;
- for withdrawable circuit-breakers, since the plug of the auxiliary circuits has a limited number of poles: five break contacts (signalling circuit-breaker open) and five make contacts (signalling circuit-breaker closed).

General characteristics	
Insulation voltage to standard VDE 0110, Group C	660 V a.c. 800 V d.c.
Rated voltage	24 V ... 660 V a.c.
Test voltage	2 kV 50 Hz (for 1 min)
Rated overcurrent	10 A
Number of contacts	5
Contact run	6 mm ... 7 mm
Activation force	26 N
Resistance	3 mΩ
Storage temperature	-20 °C ... +120 °C
Operating temperature	-20 °C ... +70 °C
Contact overtemperature	20 K
Number of cycles	30.000
Unlimited breaking capacity if used with 10 A fuse in series	

Electrical characteristics			
Un		Rated current	Breaking capacity
220 V a.c.	$\cos\phi = 0.7$	2.5 A	25 A
380 V a.c.	$\cos\phi = 0.7$	1.5 A	15 A
500 V a.c.	$\cos\phi = 0.7$	1.5 A	15 A
660 V a.c.	$\cos\phi = 0.7$	1.2 A	12 A
24 V d.c.	1 ms	10 A	12 A
	15 ms	10 A	12 A
	50 ms	8 A	10 A
	200 ms	6 A	7.7 A
60 V d.c.	1 ms	8 A	10 A
	15 ms	6 A	8 A
	50 ms	5 A	6 A
110 V d.c.	200 ms	4 A	5.4 A
	1 ms	6 A	8 A
	15 ms	4 A	5 A
220 V d.c.	50 ms	2 A	4.6 A
	200 ms	1 A	2.2 A
	1 ms	1.5 A	2 A
220 V d.c.	15 ms	1 A	1.4 A
	50 ms	0.75 A	1.2 A
	200 ms	0.5 A	1 A



8 Transient contact (-BGB4)

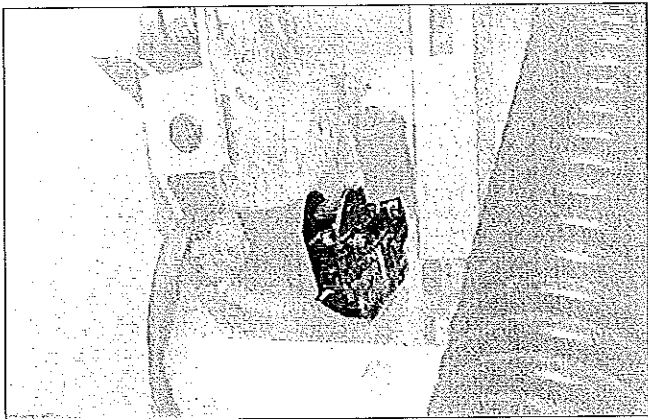

This contact closes momentarily (duration > 30 ms) on circuit-breaker opening controlled remotely with a shunt opening release.

The indication is not provided when opening is manual and local. In fact, a contact (-BGB11) is activated by the manual pushbutton and cuts off the transient contact closure (-BGB4).

The transient contact is activated directly from the main operating shaft when the indication is provided only on actual opening of the main circuit-breaker contacts.

9 Position contact (-BGT3)

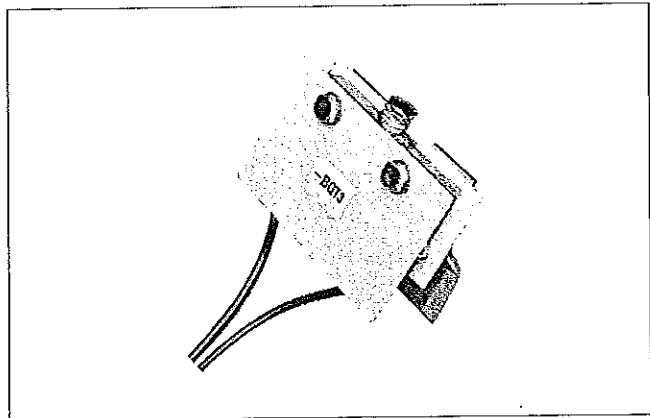

This contact is used, together with the locking magnet in the operating mechanism (-RLE1) to prevent remote closing during traverse into the unit.

It is only supplied for the withdrawable version circuit-breakers for UniGear ZS1 switchgear and PowerCube modules. It cannot be supplied when the transmitted contacts are requested in the truck (-BGT1; -BGT2).

10 Transmitted contacts in the truck (-BGT1; -BGT2)

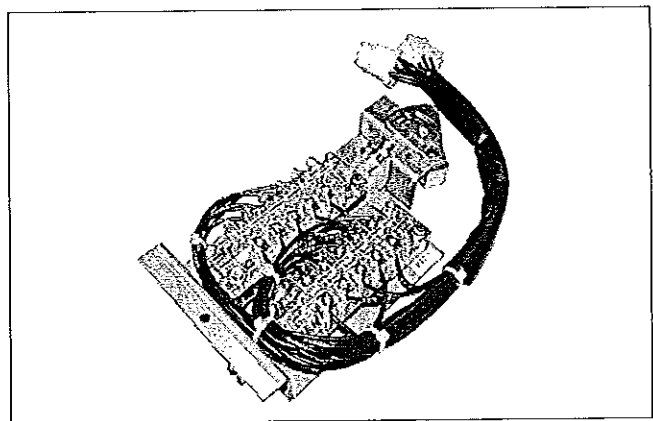

Transmitted contacts of the withdrawable circuit-breaker (installed in the circuit-breaker truck - only for VD4/P withdrawable circuit-breaker).

These contacts are either in addition or as an alternative to the position contacts (for signalling circuit-breaker racked out) located in the unit. They also carry out the function of the position contact (-BGT3).

Contacts -BGT1 and BGT2 have the same general and electrical characteristics as auxiliary contacts "70": -BGB1, -BGB2, -BGB3".

## 2. Selection and ordering Optional accessories

### 11 Motor operator (-MAS)

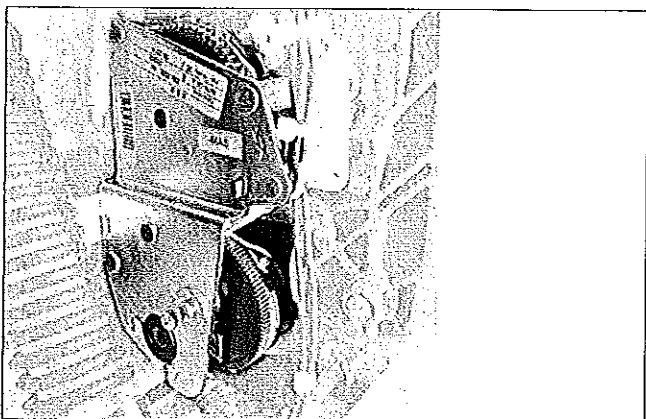

This carries out automatic charging of the circuit-breaker operating mechanism closing spring. After circuit-breaker closing, the geared motor immediately recharges the closing springs.

In the case of a power cut or during maintenance work, the closing spring can be charged manually in any case (by means of the special crank handle incorporated in the operating mechanism).

### 12 Contact for signalling closing spring charged/ discharged (-BGS2)

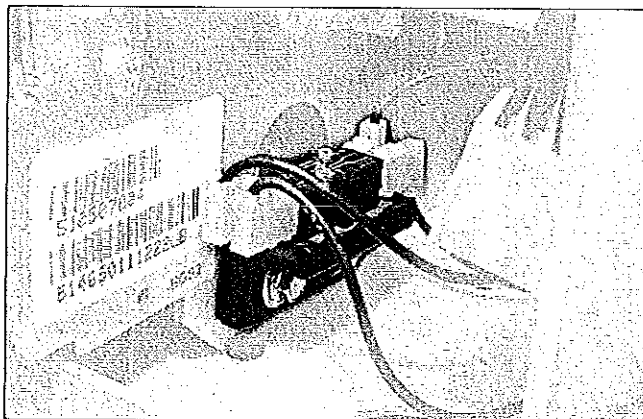

This consists of a microswitch which allows remote signalling of the state of the circuit-breaker operating mechanism closing spring.

The following signals are possible:

- contact open: signalling spring charged
- contact closed: signalling spring discharged.

The two signals must be used for circuits which have the same power supply voltage.

Characteristics		
Un	24...30 - 48...60 - 110...130 - 220...250 V~	
Un	100...130 - 220...250 V~ 50/60 Hz	
Operating limits	85 ... 110% Un	
Power on inrush (Ps)	≤ 40 kA	50 kA
	DC = 600 W; AC = 600 VA	DC = 900 W; AC = 900 VA
Rated power (Pn)	DC = 200 W; AC = 200 VA	DC = 350 W; AC = 350 VA
	Charging time	0,2 s
Charging time	6-7 s	6-7 s
Insulating voltage	2000 V 50 Hz (for 1 min)	2000 V 50 Hz (for 1 min)

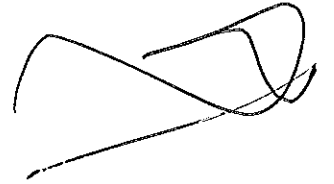

## Protections and locks

Various mechanical and electromechanical locking and protection devices are available.

### 13 Opening and closing pushbutton protection

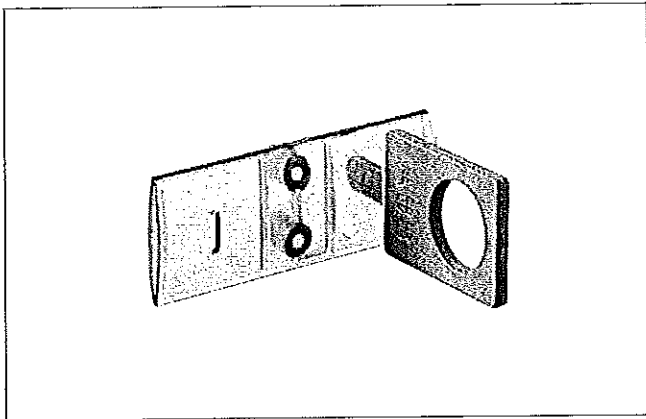

The protection only allows the opening and closing pushbuttons to be operated using a special tool.

### 14 Opening and closing pushbutton padlock

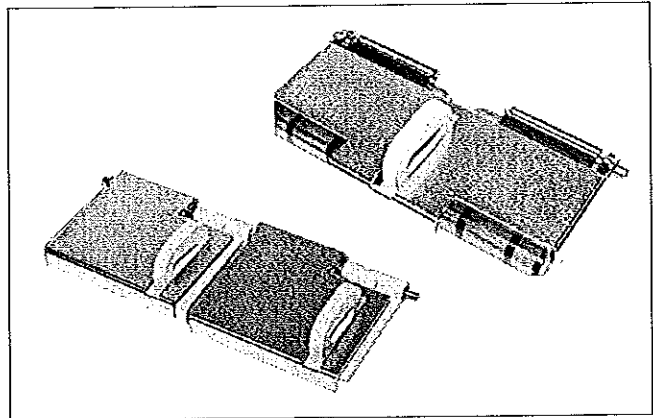

The device allows the opening and closing pushbuttons to be locked using a maximum of three padlocks (not supplied):  $\varnothing$  4 mm. Also prevents closing using remote control.

This lock is available in two versions:

**14A** Possibility of padlocking both the pushbuttons without distinction

**14B** Separate padlocking of the opening and/or closing pushbutton.

N.B. Lock 14A prevents closure by remote control; lock 14B does not prevent closure by remote control.



## 2. Selection and ordering Optional accessories

15 Key lock in open position

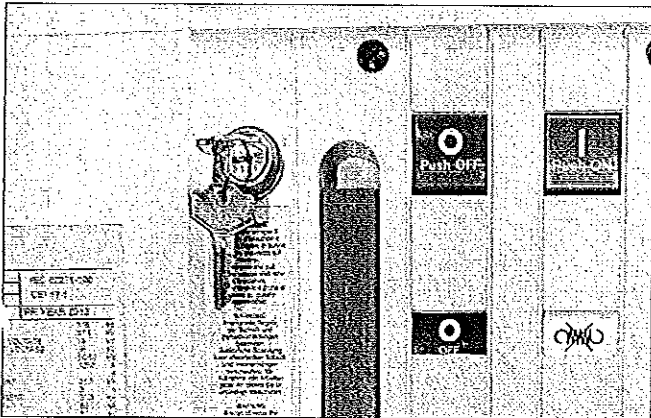

16 Locking magnet on the operating mechanism (-RLE1)

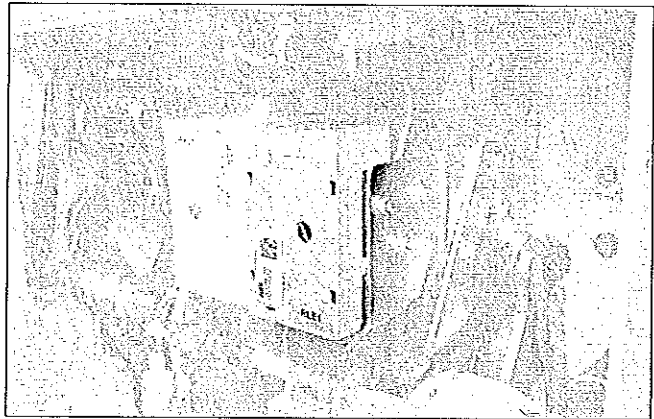

The lock is activated by a special circular lock.  
Different keys (for a single circuit-breaker) are available, or the same keys (for several circuit-breakers).  
To activate the lock, keep the opening pushbutton pressed down, turn the key and remove it.  
With the key removed, the opening pushbutton automatically remains in the pressed position preventing local manual closing and remote electrical closing.

Only allows activation of the command with the electromagnet supplied.  
The locking electromagnet in the operating mechanism has the same electrical characteristics as shunt closing release -MBC.

### 17 Locking magnet on the truck (-RLE2)

### 18 Interlock for fixed circuit-breaker

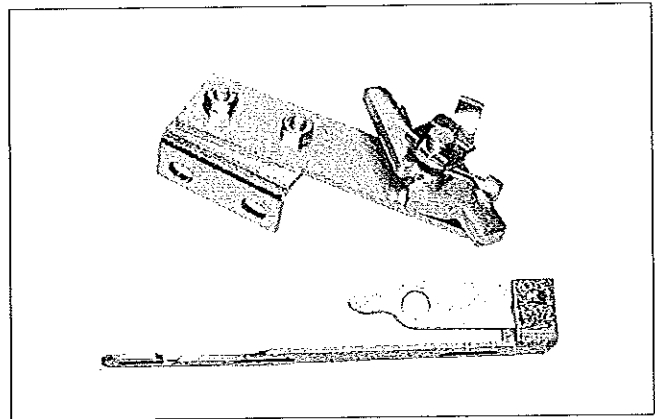
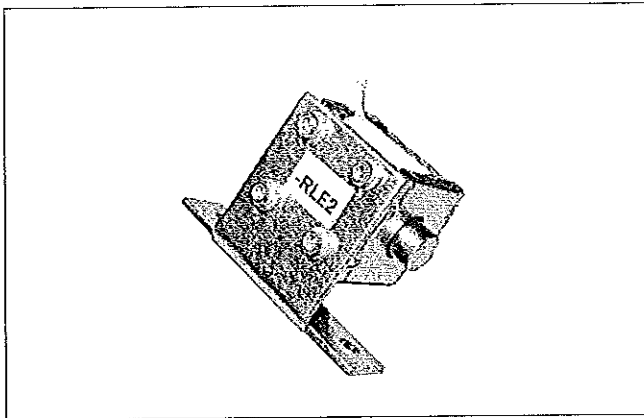

Compulsory accessory for the withdrawable versions for UniGear ZS1 switchgear and PowerCube modules, to prevent circuit-breaker racking into the switchgear with the auxiliary circuit plug disconnected.

The plug also makes the anti-insertion lock for a different rated current. Special striker pins do not allow insertion of the plug in the socket if the rated current of the circuit-breaker is lower than the rated current of the panel.

**Note:** a specific version for the circuit-breakers of ZS8.4 switchgear is available on request. This accessory is not available when the motor-operated truck is required.

Device for fixed circuit-breakers which are converted into withdrawable ones by the customer. It allows a mechanical lock to be made, by the customer, which prevents racking-out/in with the circuit-breaker closed and prevents circuit-breaker closing during translation.

**Note:** The device must be requested when ordering since it must be assembled and tested in the factory.

Characteristics	
Un	24 - 30 - 48 - 60 - 110 - 125 - 127 - 132 - 220 - 240 V-
Un	24 - 30 - 48 - 60 - 110 - 125 - 127 - 220 - 230 ... 240 V- 50/60 Hz
Operating limits	85 ... 110% Un
Nominal power (Pn)	DC 250 W; AC = 250 VA
Continuous power (Pc)	DC = 5 W; AC = 5 VA
Inrush duration	150 ms
Insulating voltage	2000 V 50 Hz (for 1 min)

## 2 Selection and ordering Optional accessories

### 19 Mechanical interlock with the door

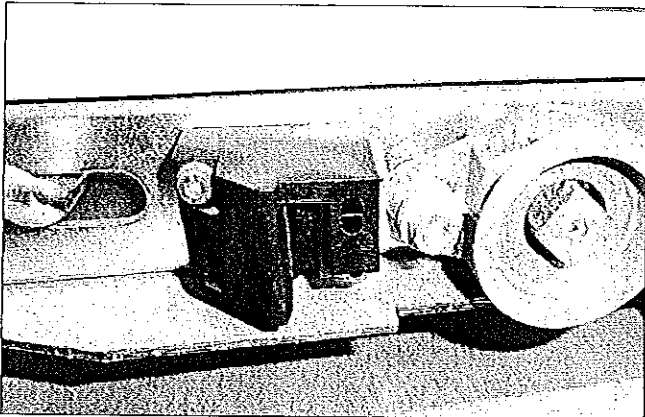

This device prevents circuit-breaker racking-in when the switchgear door is open. It is only provided for circuit-breakers used in switchgear UniGear ZS1 and PowerCube modules, fitted with a special actuator on the door.

### 20 Motorised truck (-MAT)

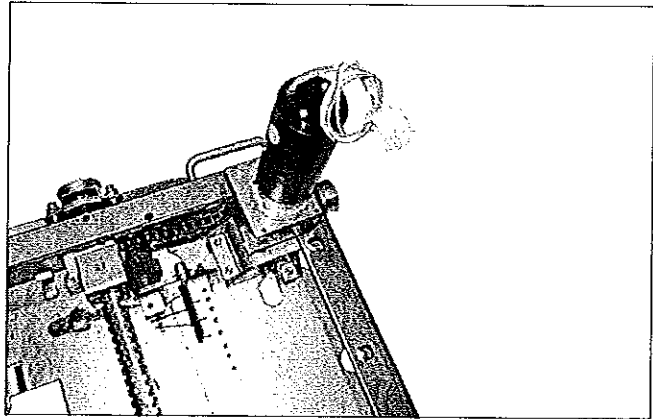

It allows racking-in and racking-out of the circuit-breaker in the switchgear to be carried out remotely, (only for circuit-breaker in withdrawable version for UniGear ZS1 and ZS8.4 switchgear and PowerCube modules).

The motor version with clutch can be ordered on request, so that racking-in/ out can be performed in an emergency if the truck motor fails to operate.

#### Characteristics

Un	24 - 30 - 48 - 60 - 110 - 220 V-
Operating limits	85 ... 110% Un
Nominal power (Pn)	40 W





21 STU Shunt Test Unit

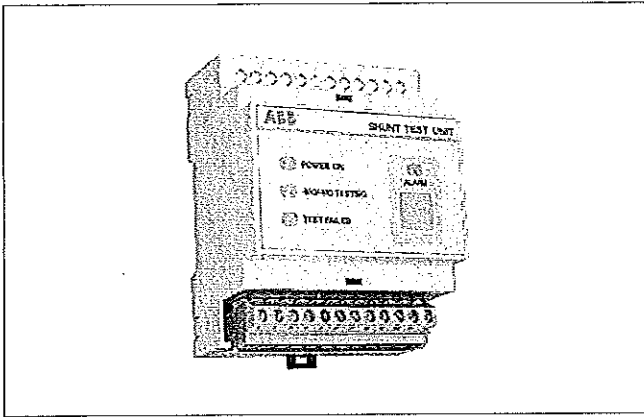

Due to the particular construction of these releases, checking the functionality of the shunt closing (-MBC) and opening (-MBO1, -MBO2) releases is not possible with dedicated relays (e.g. TCS Test Control Supervision, CCC Control Coil Continuity) or with the REF control and protection unit. The only device able to carry out a check of the functionality is the STU device. Please contact us if you want to carry out this control with devices other than STU.

This device can be combined with the shunt opening release (-MBO1; -MBO2) or with the shunt closing release (-MBC) to check functionality and continuity.

The control/monitoring Shunt Test Unit allows the continuity of releases with a rated operating voltage between 24 V and 250 V (AC and DC) to be checked, as well as the functionality of the electronic circuit of the release.

Checking continuity is carried out cyclically with an interval of 20 seconds between one test and the next.

The unit has optical signals by means of LEDs on the front. In particular the following information is indicated:

- POWER ON: power supply present
- (-MO) TESTING: test being carried out
- TEST FAILED: signal following a failed test or in the absence of auxiliary power supply
- ALARM: signal after three failed tests.

Two relays and a changeover are also available on board the unit, which allow remote signalling of the following two events:

- failure of a test (resetting is carried out automatically when the alarm stops)
- failure of three tests (resetting is only carried out by means of the manual - RESET - from the front of the unit).

There is also a manual - RESET - button on the front of the unit.

Characteristics	
Un	24 ... 250 V AC/DC
Maximum interrupted current	6 A
Maximum interrupted voltage	250 V AC

### 3. Specific product characteristics

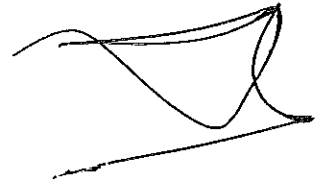

#### Resistance to vibrations

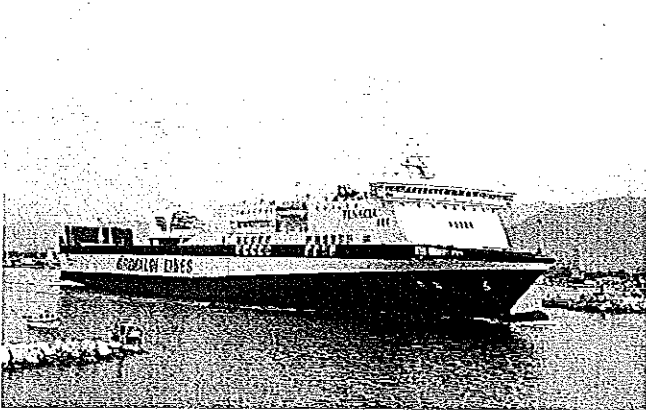

The VD4 circuit-breakers are designed to satisfy high levels of resistance to stresses caused by mechanical vibrations. Many versions are able to satisfy both the approval criteria of the major International Shipping Registers (DNV, Lloyd's Register, RINA) and the qualification criteria of the International Seismic Standards (IEEE 344, IEEE 323 and IEC 60980). For the versions approved by the shipping registers, please contact us.

Galvanisation is carried out in accordance with UNI ISO 2081 Standards, classification code Fe/Zn 12, with a thickness of  $12 \times 10^{-6}$  m, protected by a conversion layer mainly consisting of chromates in compliance with the UNI ISO 4520 Standard.

#### Altitude

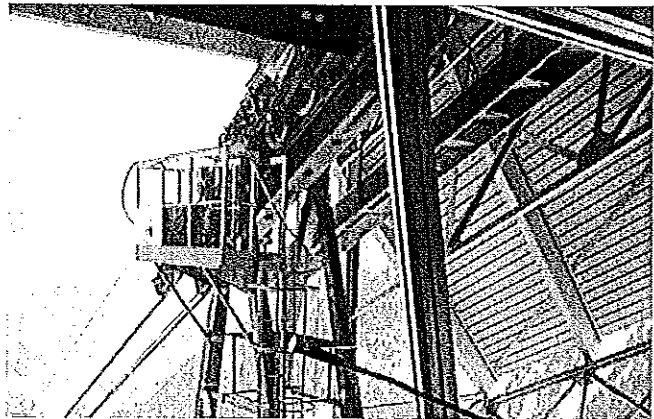

#### Tropicalization



VD4 circuit-breakers are manufactured in compliance with the strictest regulations regarding use in hot-humid-saline climates.

All the more important metal parts are treated against corrosive substances corresponding to standard EN 12500 class C5 atmospheric corrosion.

The insulating property of air decreases as the altitude increases, therefore this must always be taken into account for external insulation of the apparatus (the internal insulation of the interrupters does not undergo any variations as it is guaranteed by the vacuum).

The phenomenon must always be taken into consideration during the design stage of the insulating components of apparatus to be installed over 1000 m above sea level. In this case a correction coefficient must be considered, which can be taken from the graph on the next page, built up on the basis of the indications in the IEC 62271-1 Standards. The following example is a clear interpretation of the indications given above.

### Graph for determining the Ka correction factor according to the altitude

#### Example

- Installation altitude 2000 m
- Operation at the rated voltage of 12 kV
- Withstand voltage at power frequency 28 kV rms
- Impulse withstand voltage 75 kVp
- Ka factor obtained from graph = 1.13.

Considering the above parameters, the apparatus will have to withstand (under test and at zero altitude, i.e. at sea level):

- withstand voltage at power frequency equal to:  
 $28 \times 1.13 = 31.6$  kVrms
- Impulse withstand voltage equal to:  
 $75 \times 1.13 = 84.7$  kVp.

From the above, it can be deduced that for installations at an altitude of 2000 m above sea level, with 12 kV service voltage, apparatus must be provided with 17.5 kV rated voltage, characterised by insulation levels at power frequency of 38 kVrms with 95 kVp impulse withstand voltage.

H = altitude in metres;  
m = value referred to power frequency and the lightning impulse withstand voltages and those between phases.

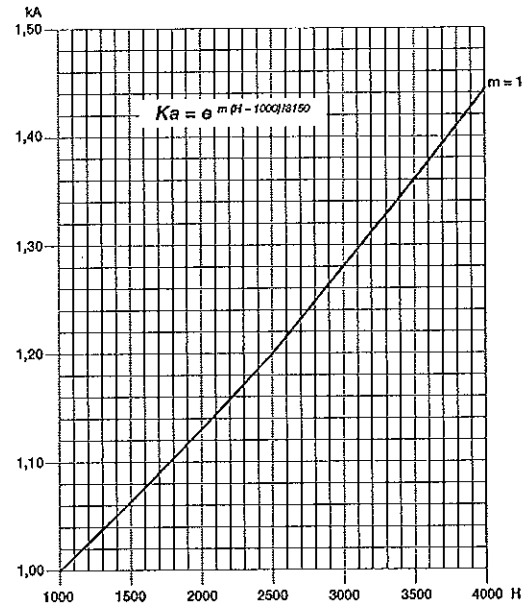

### Anti-pumping device

The EL operating mechanism of VD4 circuit-breakers (in all versions) is fitted with a mechanical anti-pumping device which prevents re-closing due to either electrical or mechanical commands.

Should both the closing command and any one of the opening commands (local or remote) be active at the same time, there would be a continuous succession of opening and closing commands.

The anti-pumping device avoids this situation, ensuring that each closing operation is only followed by an opening operation and that there is no other closing operation after this. To obtain a further closing operation, the closing command must be released and then re-launched.

Furthermore, the anti-pumping device only allows circuit-breaker closure if the following conditions are present at the same time:

- operating mechanism spring fully charged
- opening pushbutton and/or shunt opening release (-MBO1/-MBO2) not activated
- circuit-breaker open.

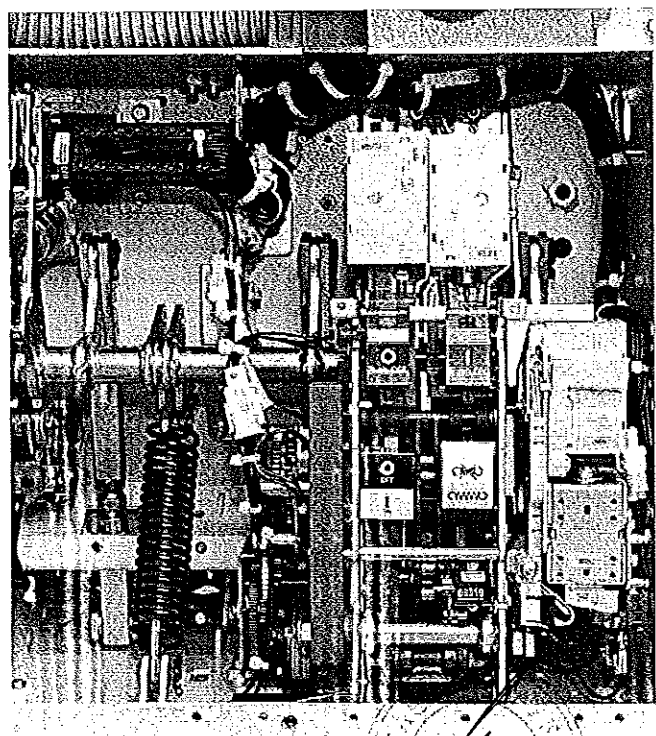

### 3. Specific product characteristics

#### REF 601 protection Device

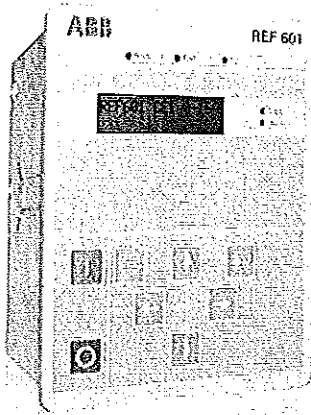

The characteristics of the device are:

- trip precision
- wide adjustment ranges
- single and simultaneous adjustment of the three phases
- no limitation (due to the current sensors) to the rated breaking capacity and at the short-time withstand current of the circuit-breaker
- pushbuttons for local electrical operation of the circuit-breaker (opening and closing pushbutton)
- 5 distinct indicators: "relay in operation", "relay in trip threshold", "relay tripped", "relay tripped due to exceeding phase current", "relay tripped due to exceeding ground fault current"
- interface consisting of an LCD display and of "arrow" keys, "enter" and "esc" for easier navigation inside the "measurement", "data recording", "event recording", "settings", "configuration" and "test" menus
- three user levels: "operator" (only display, with free access, by keeping this key pressed for at least 5 sec.), "configurator" (like the previous one, but also with permission to set the protection parameters, i.e. times and thresholds, and communication, if present - access limited by a password), "administrator" (like the previous ones, but also with permission to set the password and configure the basic settings of the device, such as the rated current - access limited by a password)
- continual display of the current on the most highly loaded phase and of the round current
- recording of the value of the currents which caused the device to trip
- storage of the number of openings carried out by the device
- event log (storage of the parameters described above in the last 5 trips of the device) in a non-volatile memory
- curves " $\beta = 1$ " or " $\beta = 5$ " and curve "RI" specific for the Belgian market (only REF 601 IEC)
- circuit-breaker opening by means of an undervoltage release (only REF 601 CEI)
- version, on request, with RS485 4-wire serial communication
- MODBUS RTU full duplex protocol
- multi-voltage feeder 24 ... 240 V a.c.- d.c

On request, the REF 601 switchgear protection device is available for protection of the installations, which requires an auxiliary power supply for its operation unlike the previous PR512 which was a self-supplied release.

The REF 601 has protections and trip curves in accordance with the IEC 255-3 Standard. It sees to the protection function against overload (51), against instantaneous and delayed short-circuit (50-51) and against instantaneous and delayed homopolar ground fault (50N and 51N). It also detects the second harmonic component to prevent unwarranted tripping on connection of a transformer (68).

The unit has 3 inputs from current sensors of the type with Rogowsky coil, one input from external toroidal CT and from the keyboard 4 rated currents can be set: 40, 80, 250 and 1250 A.

If the unit is connected to 3 current sensors, the 50N and 51N protection functions are carried out with the vectorial sum of the phase currents; if only 2 current sensors are used, then the external toroidal current transformer must be provided for functions 50N and 51N.

The external toroidal current transformer can be with openable core or closed and with any transformation ratio as long with a 1 A secondary current.

The ABB current sensors of the type with Rogowsky coil provided for REF 601, are only suitable for installation on MV insulated cables.

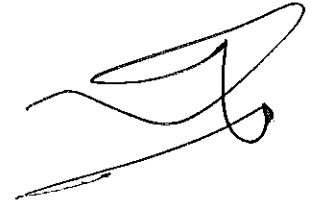
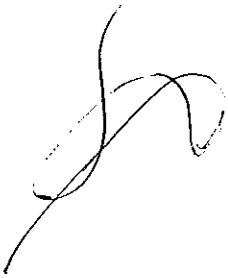

## Environmental protection programme

VD4 circuit-breakers are manufactured in accordance with the ISO 14000 Standards (Guidelines for environmental management).

The production processes are carried out in compliance with the Standards for environmental protection in terms of reduction in energy consumption as well as in raw materials and production of waste materials. All this is thanks to the medium voltage apparatus manufacturing facility environmental management system.

Assessment of the environmental impact of the life cycle of the product, obtained by minimising energy consumption and overall raw materials of the product, became a concrete matter during the design stage by means of targeted selection of the materials, processes and packing.

This is to allow maximum recycling at the end of the useful life cycle of the apparatus.

## Spare parts

- Shunt opening release
- Additional shunt opening release
- Undervoltage release
- Time delay device for undervoltage release
- Shunt closing release
- Spring charging geared motor with electrical signalling of spring charged
- Contact signalling geared motor protection circuit-breaker open/closed
- Contact signalling closing spring charged/discharged
- Transient contact with momentary closing during circuit-breaker opening
- Circuit-breaker auxiliary contacts
- Locking electromagnet on the operating mechanism
- Position contact of the withdrawable truck
- Contacts signalling connected/isolated
- Opening solenoid
- Key lock in open position
- Isolation interlock with the door
- Protection for opening pushbutton
- Protection for closing pushbutton
- Locking electromagnet on the withdrawable truck
- Set of six isolating contacts.

## Ordering

For availability and to order spare parts, please contact our Service department, specifying the circuit-breaker serial number.



# 4. Overall dimensions

## Fixed circuit-breakers

VD4	
TN	7405
Ur	12 kV
	17.5 kV
Ir	630 A
	1250 A
Isc	16 kA
	20 kA
	25 kA
	31.5 kA

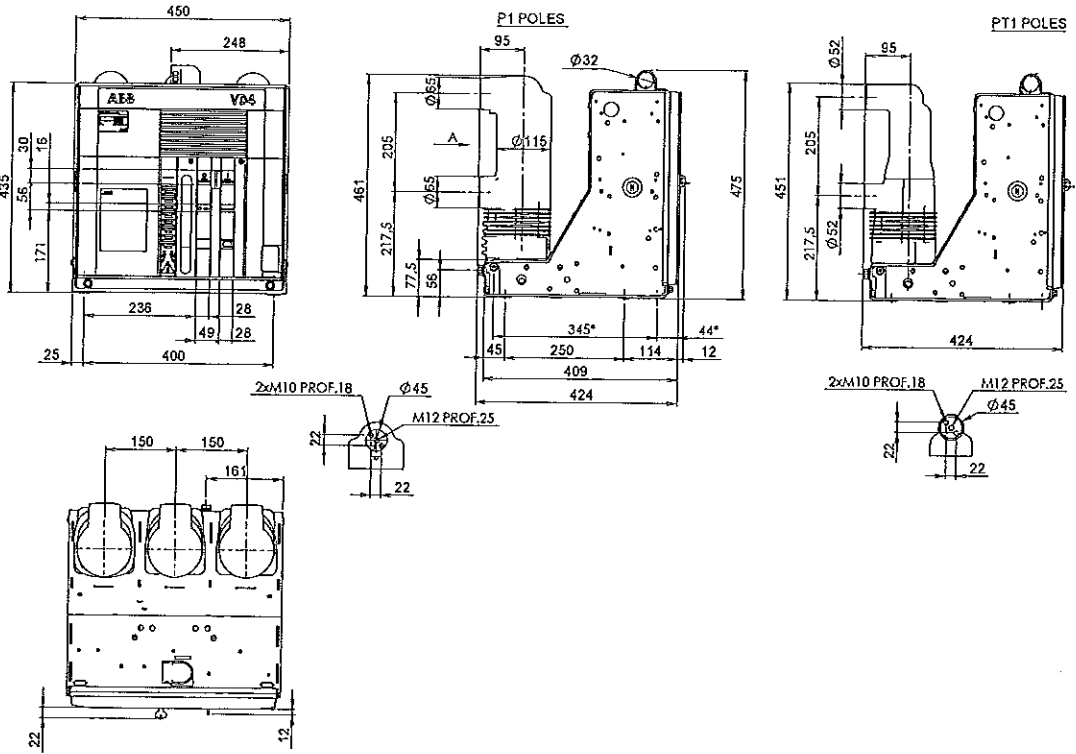

(\*) Fixing interchangeability with previous series (345 x 400).

## Fixed circuit-breakers

VD4	
TN	7406
Ur	12 kV
	17.5 kV
Ir	630 A
	1250 A
Isc	16 kA
	20 kA
	25 kA
	31.5 kA

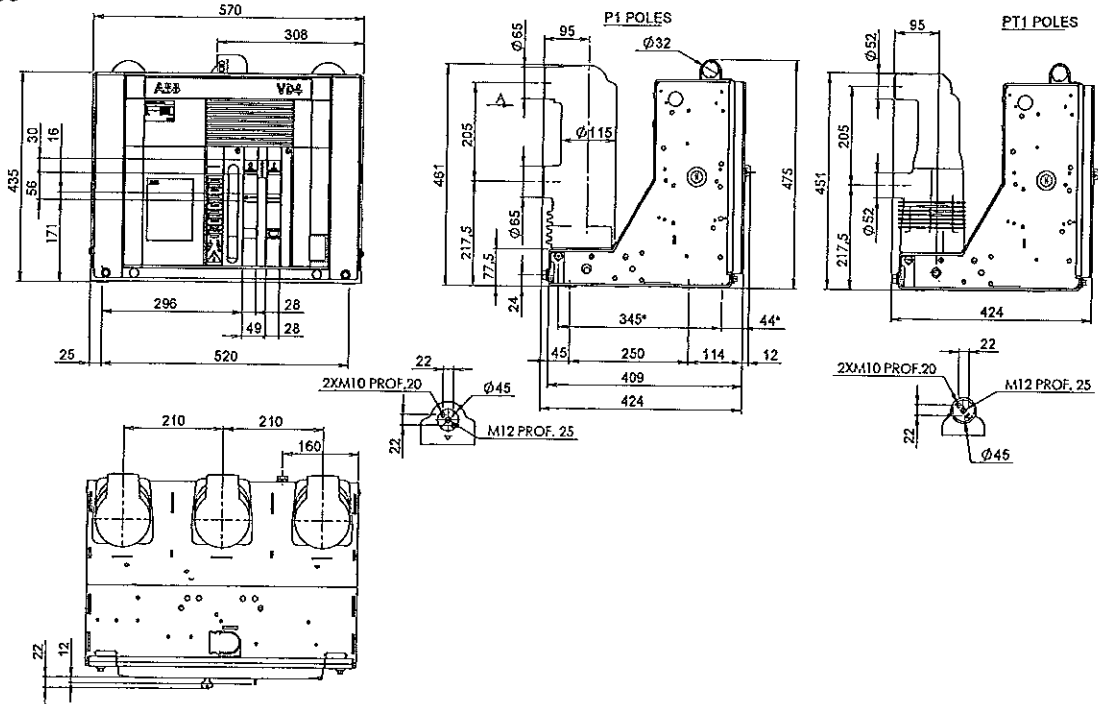

(\*) Fixing interchangeability with previous series (345 x 520).

Fixed circuit-breakers

VD4	
TN	1VCD000051
Ur	12 kV 17.5 kV
Ir	630 A 1250 A
IsC	16 kA 20 kA 25 kA 31.5 kA

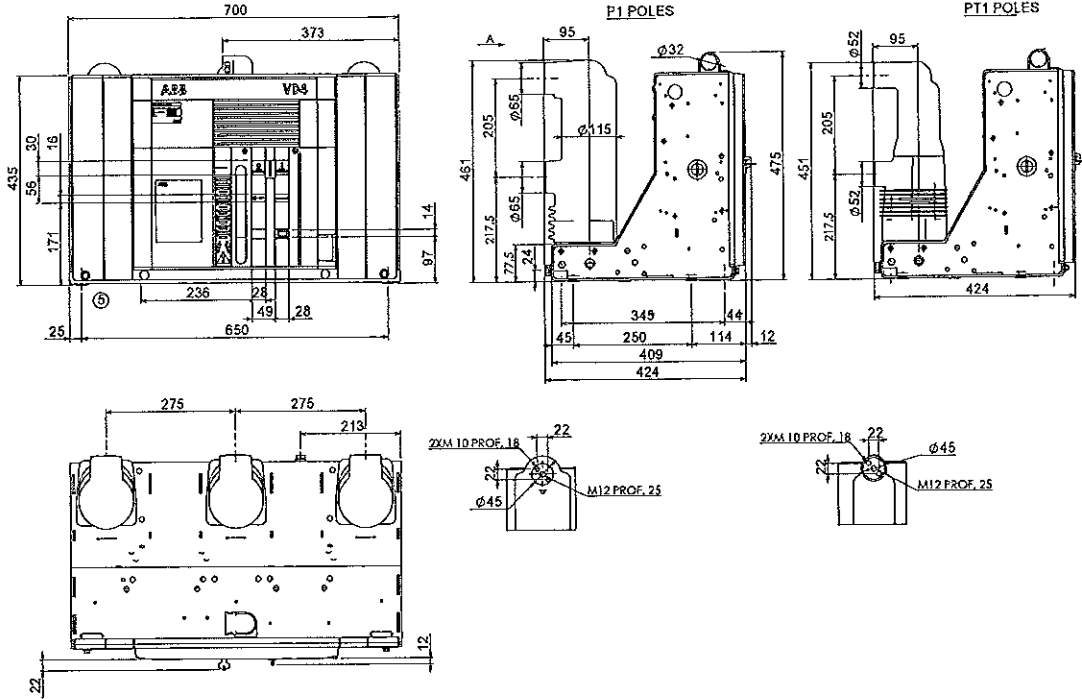

(\*) Fixing interchangeability with previous series (345 x 650).

Fixed circuit-breakers

VD4	
TN	1VCD003282
Ur	12 kV 17.5 kV
Ir	1250 A 1600 A
IsC	40 kA

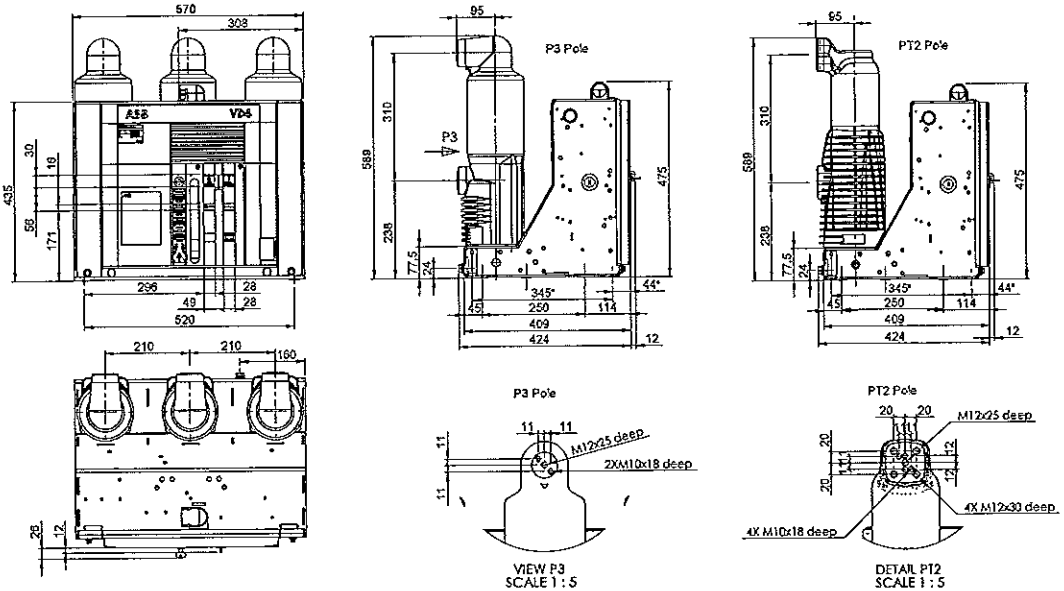

(\*) Fixing interchangeability with previous series (345 x 650).

# 4. Overall dimensions

## Fixed circuit-breakers

VD4	
TN	1VCD003285
Ur	12 kV
	17.5 kV
Ir	1250 A
	1600 A
Isc	40 kA

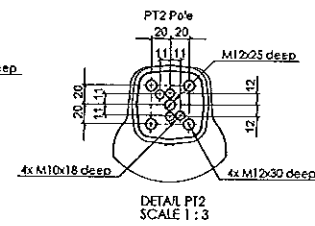
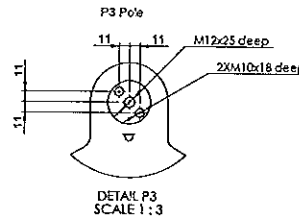
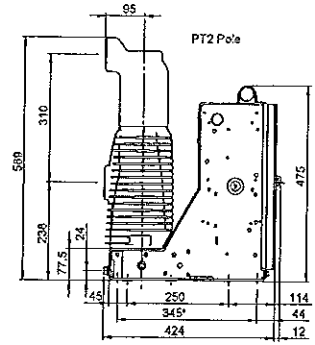
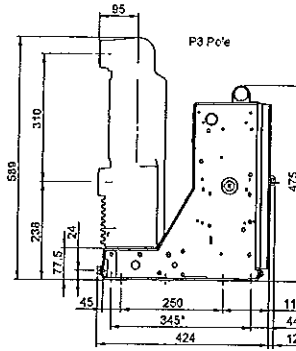
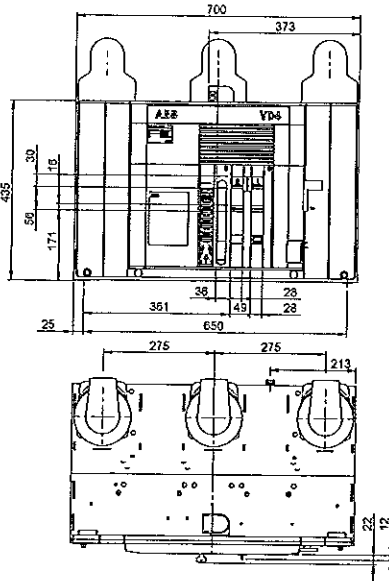

(\*) Fixing interchangeability with previous series (345 x 650).

## Fixed circuit-breakers

VD4	
TN	1VCD003440
Ur	12 kV
	17.5 kV
Ir	1250 A
	1600 A
Isc	2000 A
	50 kA

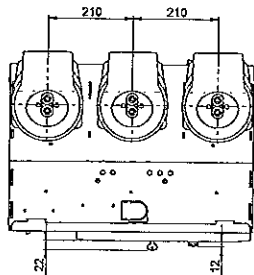
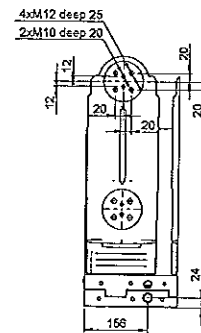
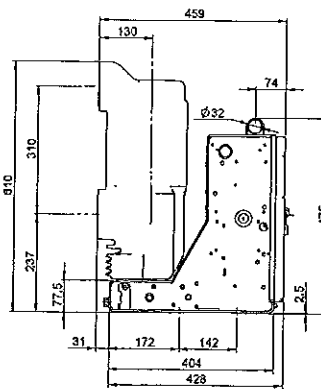
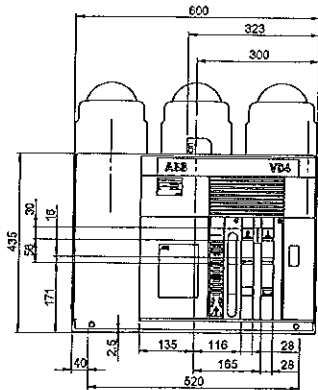



Fixed circuit-breakers

VD4	
TN	1VCD003441
Ur	12 kV
	17.5 kV
Ir	1250 A
	1600 A
	2000 A
	2500 A
Isc	50 kA

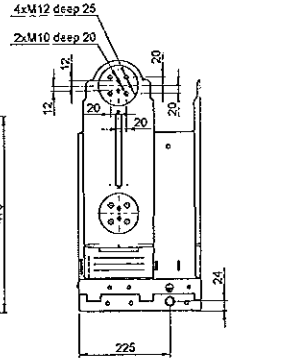
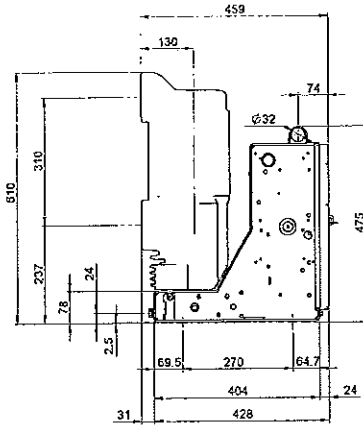
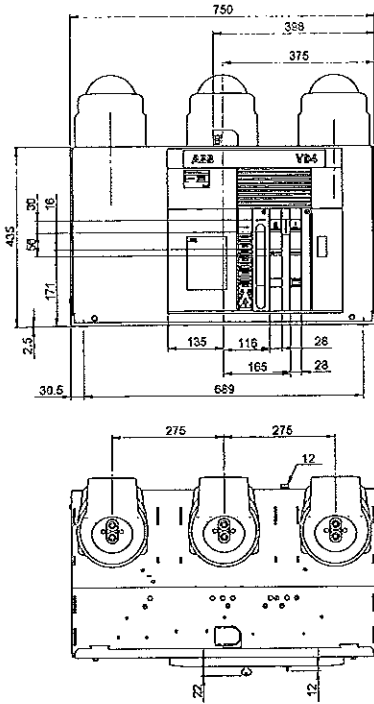

DETAIL A  
SCALE 1:2.5

Fixed circuit-breakers

VD4	
TN	1VCD000050
Ur	12 kV
	17.5 kV
Ir	1600 A
	20 kA
	25 kA
	31.5 kA

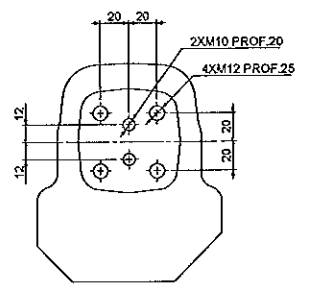
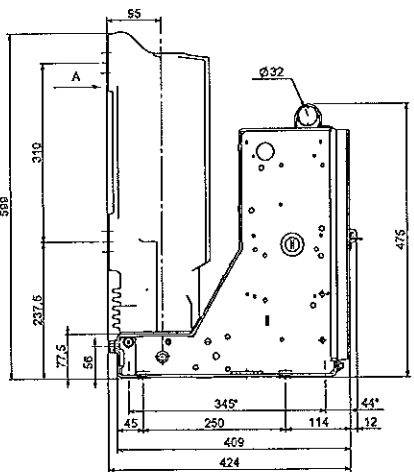
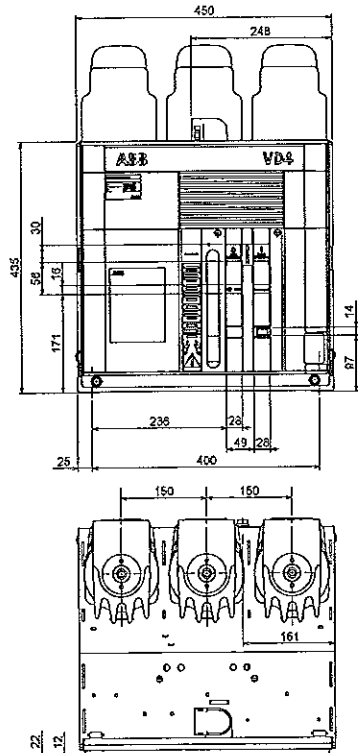

DETAIL A  
SCALE 1:2.5

(\*) Fixing Interchangeability with previous series (345 x 400).

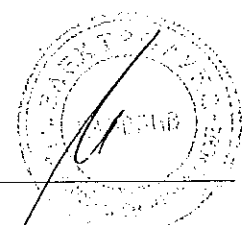



Fixed circuit-breakers

VD4	
TN	1VCD000149
Ur	12 kV
	17.5 kV
Ir	3150 A
Isc	20 kA
	25 kA
	31.5 kA
	40 kA

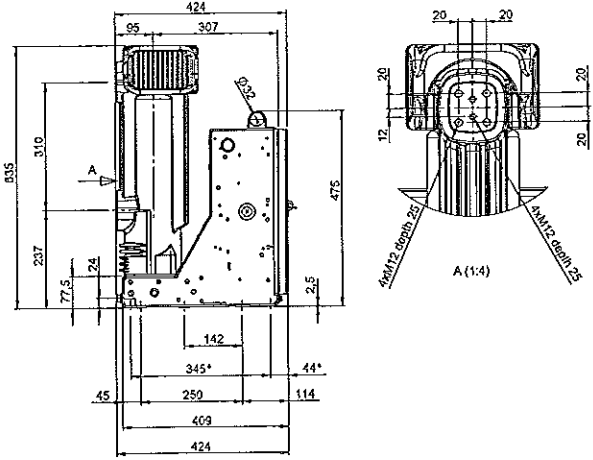
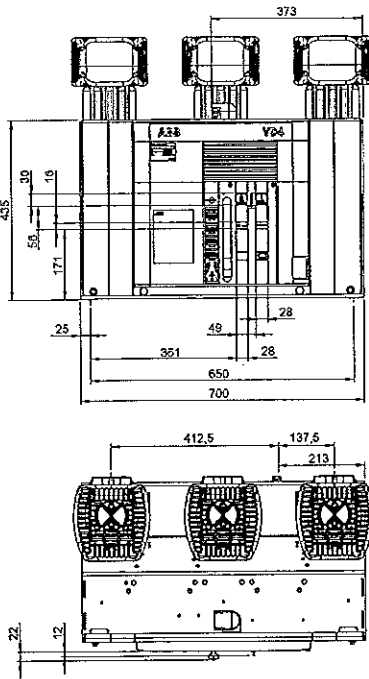

(\*) Fixing interchangeability with previous series (345 x 650).

Fixed circuit-breakers

VD4	
TN	1VCD003443
Ur	12 kV
	17.5 kV
Ir	3150 A (*)
Isc	50 kA

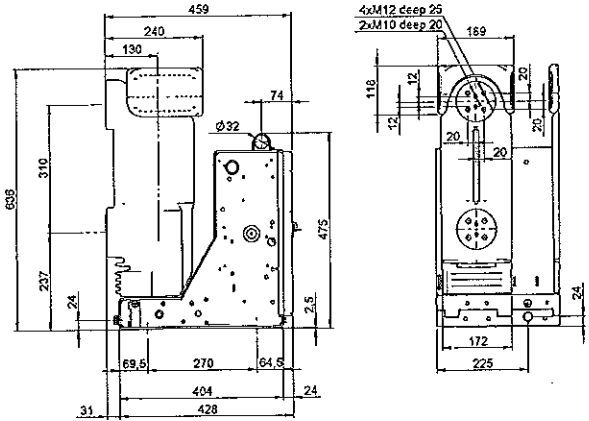
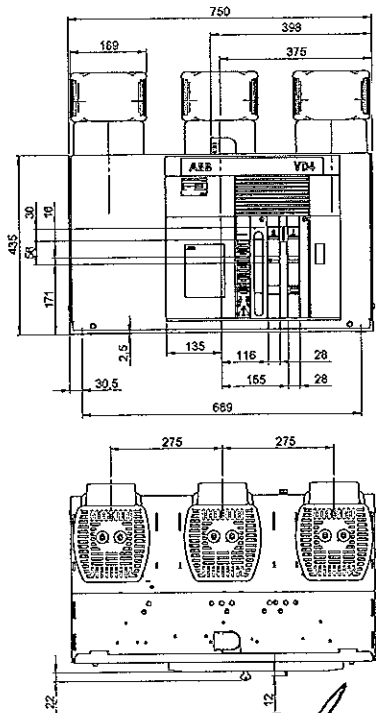

(\*) 4000 A with forced ventilation.

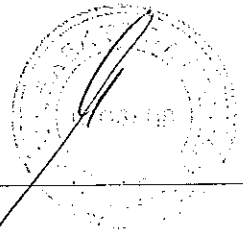

# 4. Overall dimensions

## Fixed circuit-breakers

VD4	
TN	7409
Ur	24 kV
Ir	630 A
	1250 A
Isc	16 kA
	20 kA
	25 kA

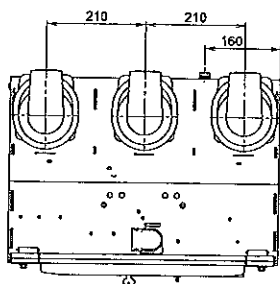
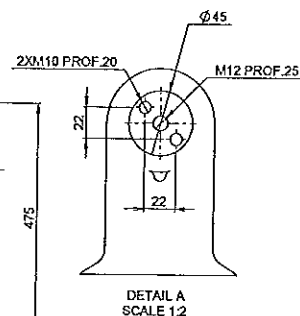
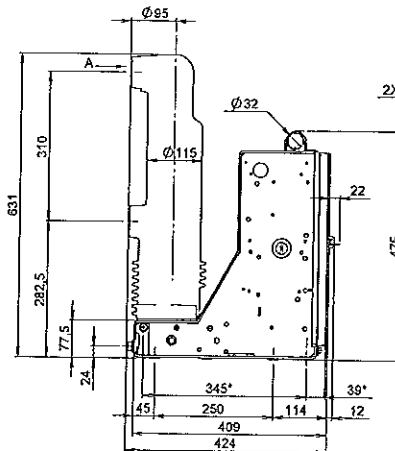
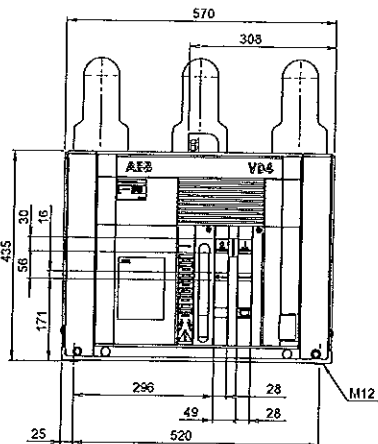

## Fixed circuit-breakers

VD4	
TN	1VCD000172
Ur	24 kV
Ir	630 A
	1250 A
Isc	31,5 kA

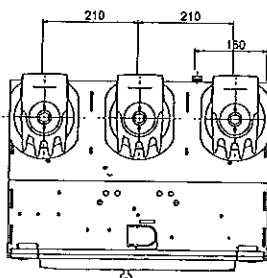
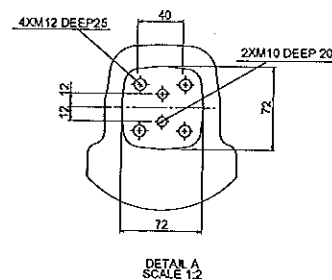
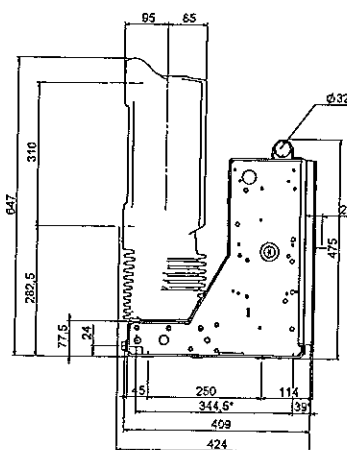
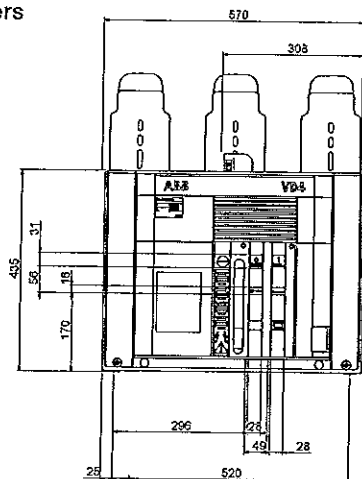

Fixed circuit-breakers

VD4	
TN	7410
Ur	24 kV
Ir	630 A
	1250 A
Isc	16 kA
	20 kA
	25 kA

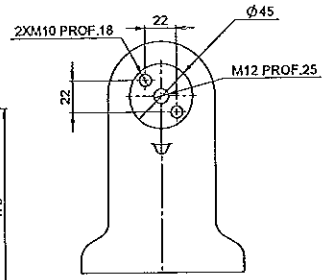
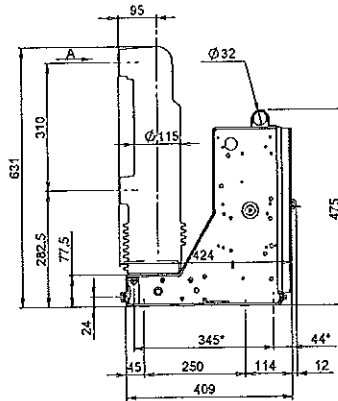
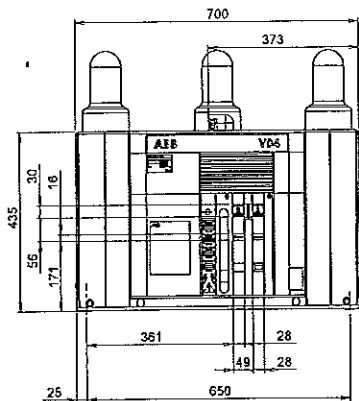

DETAIL A  
SCALE 1:2

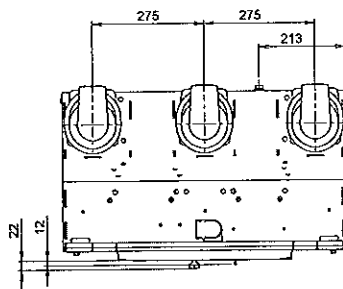

Fixed circuit-breakers

VD4	
TN	7411
Ur	24 kV
Ir	1600 A
	2000 A
Isc	2500 A
	16 kA
	20 kA
	31.5 kA

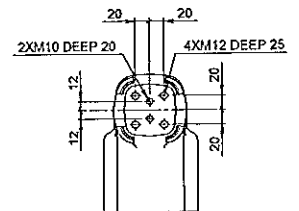
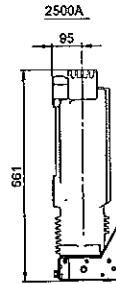
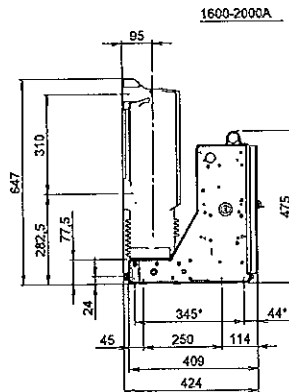
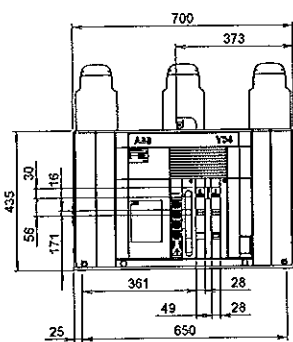

DETAIL A  
SCALE 1:2

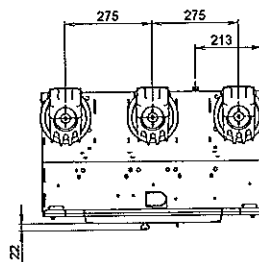

# 4. Overall dimensions

## Fixed circuit-breakers

VD4	
TN	1VYN300901-LT
Ur	36 kV
	1250 A
Ir	1600 A
	2000 A
	2500 A
Isc	20 kA
	25 kA
	31.5 kA

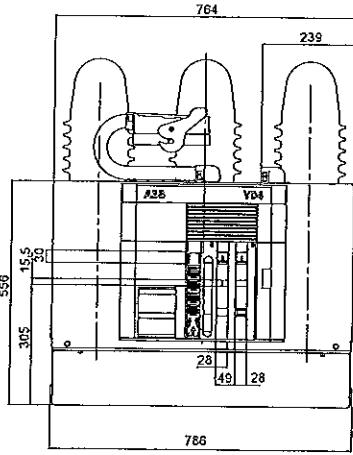

FRONT VIEW

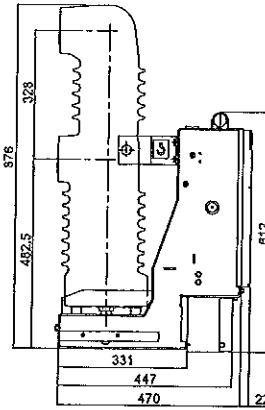

SIDE VIEW

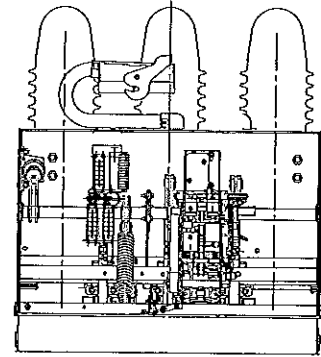

FRONT VIEW WITHOUT FRONT COVER

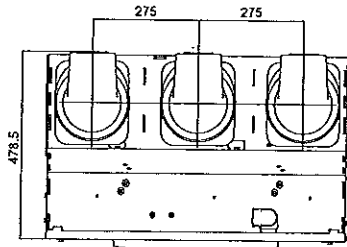

TOP

## Withdrawable circuit-breakers for UniGear ZS1 switchgear and PowerCube PB1 modules

VD4/P	
TN	7412
Ur	12 kV
	17.5 kV
Ir	630 A
	1250 A
Isc	16 kA
	20 kA
	25 kA
	31.5 kA

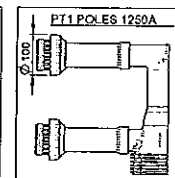
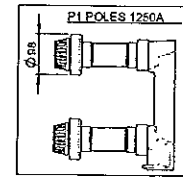
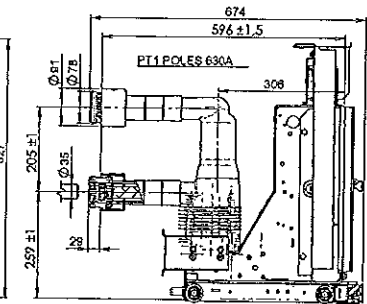
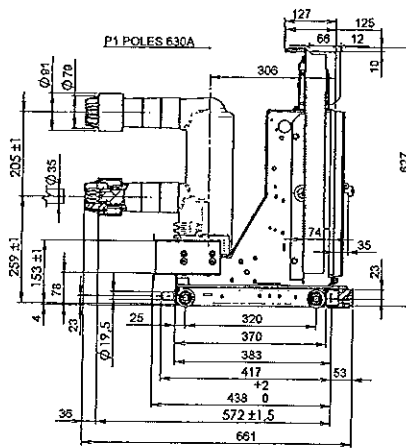
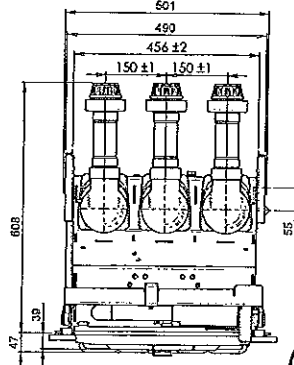
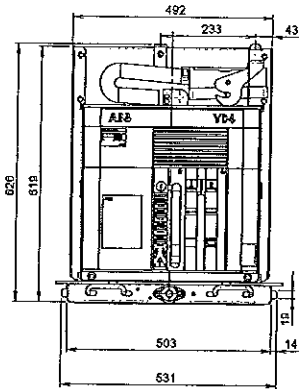



# A. Overall dimensions

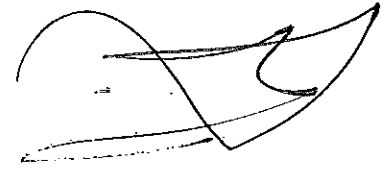

## Withdrawable circuit-breakers for UniGear ZS1 switchgear

VD4/P	
TN	1VCD003286
Ur	12 kV
	17.5 kV
Ir	1250 A
	1600 A
Isc	40 kA

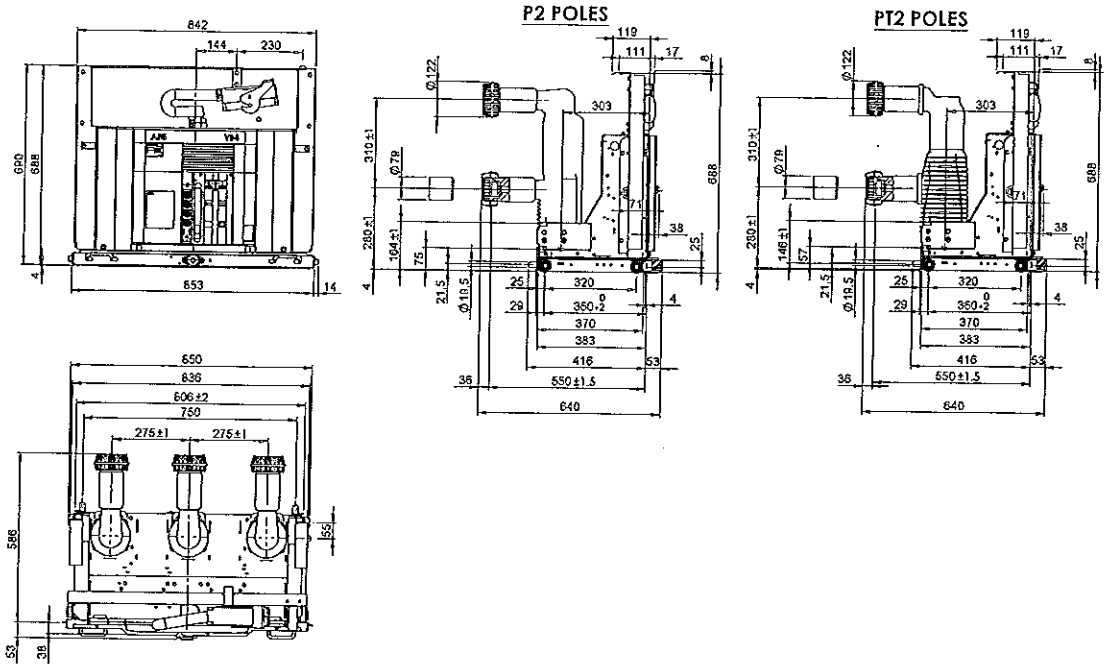

## Withdrawable circuit-breakers for UniGear ZS1 switchgear and PowerCube PB2 modules

VD4/P	
TN	1VCD 003444
Ur	12 kV
	17.5 kV
Ir	1250 A
	2000 A
Isc	50 kA

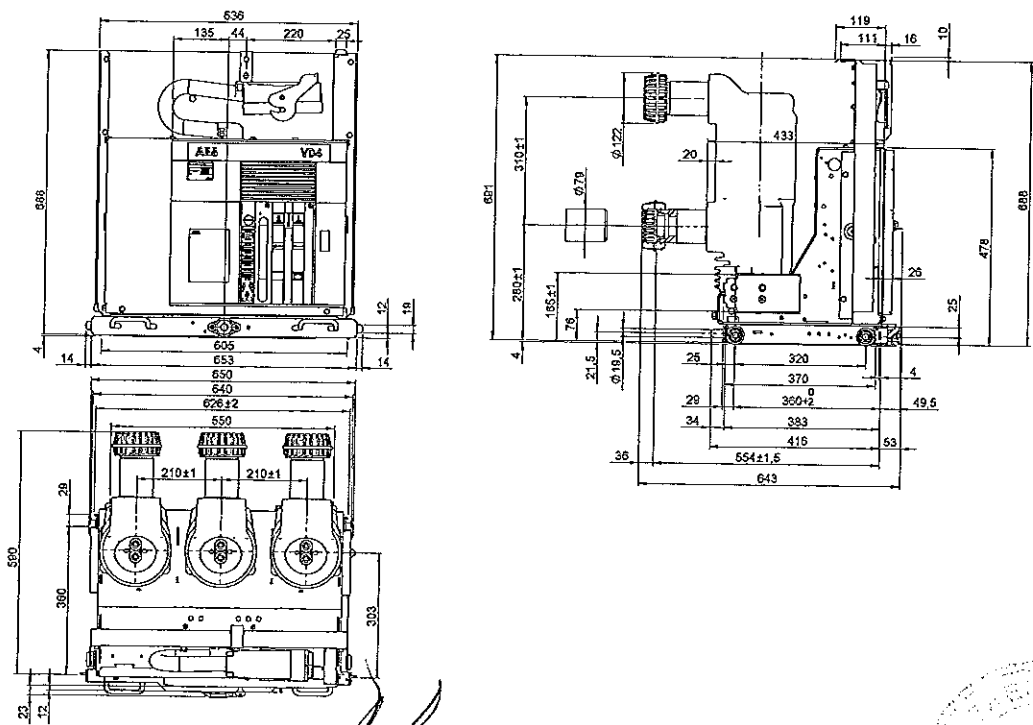



Withdrawable circuit-breakers for UniGear ZS1 switchgear and PowerCube PB2 modules

VD4/P	
TN	7415
Ur	12 kV
	17.5 kV
Ir	1600 A
	2000 A
Isc	20 kA
	31.5 kA

VD4/P	
TN	7415
Ur	12 kV
	17.5 kV
Ir	2000 A
Isc	40 kA

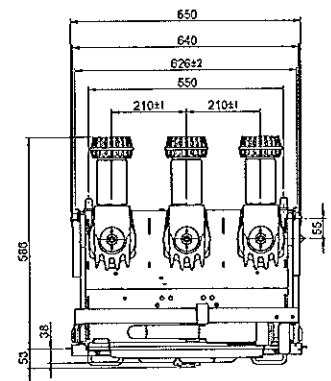
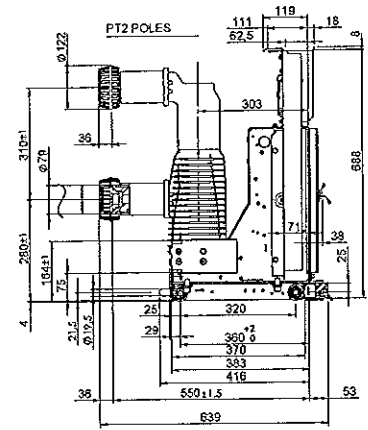
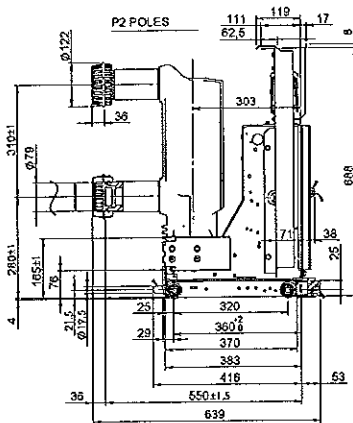
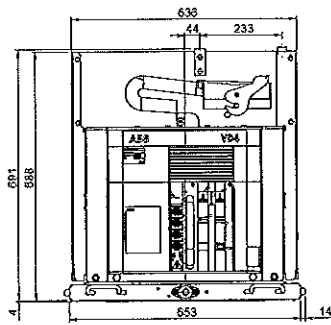

Withdrawable circuit-breakers for UniGear ZS1 switchgear

VD4/P	
TN	7416
Ur	12 kV
	17.5 kV
Ir	1600 A
	2000 A
Isc	20 kA
	31.5 kA

VD4/P	
TN	7416
Ur	12 kV
	17.5 kV
Ir	2000 A
Isc	40 kA

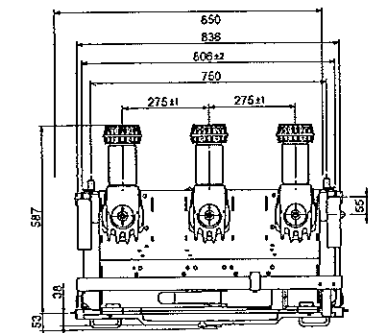
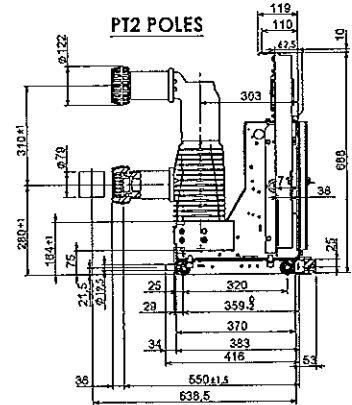
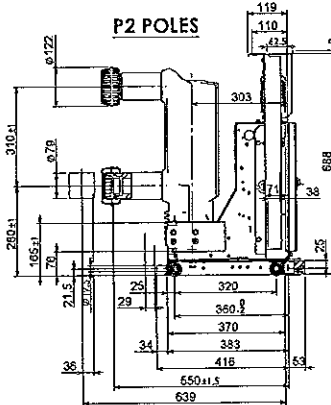
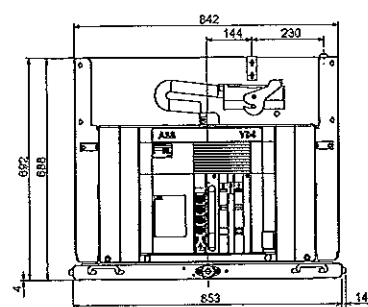

# 4. Overall dimensions

Withdrawable circuit-breakers for UniGear ZS1 switchgear and PowerCube PB3 modules

VD4/P	
TN	7417
Ur	12 kV 17.5 kV
Ir	2500 A
Isc	20 kA
	25 kA
	31.5 kA
	40 kA

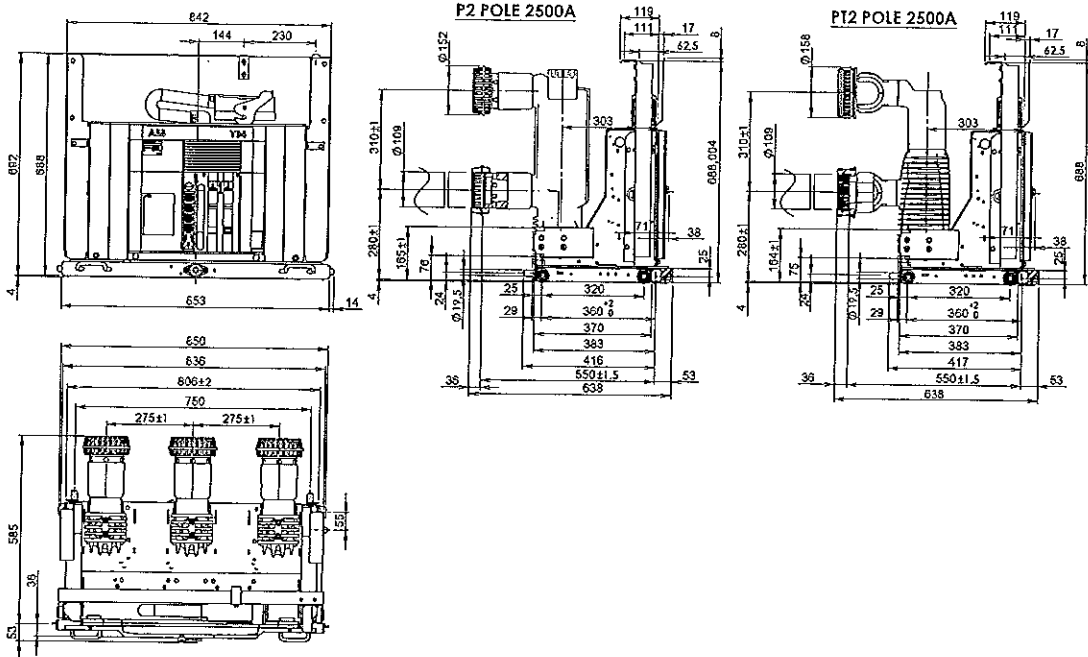

Withdrawable circuit-breakers for PowerCube PB3 modules

VD4/W	
TN	1VCD000152
Ur	12 kV 17.5 kV
Ir	3160 A (*)
Isc	20 kA
	25 kA
	31.5 kA
	40 kA

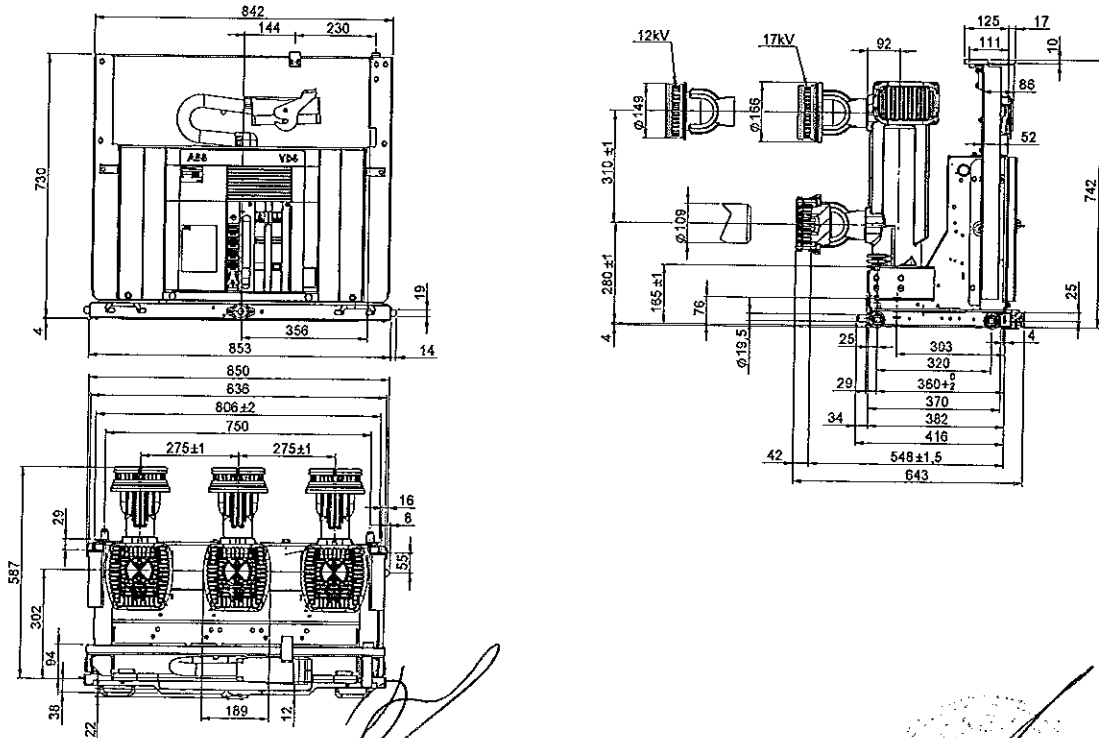

(\*) 4000 A with forced ventilation.

Withdrawable circuit-breakers for UniGear ZS1 switchgear and PowerCube PB3 modules

VD4/P	
TN	1VCD003445
Ur	12 kV
	17.5 kV
Ir	1600 A
	2000 A
Isc	50 kA

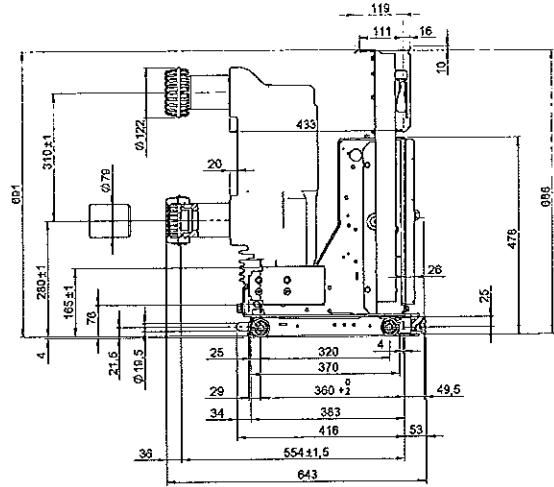
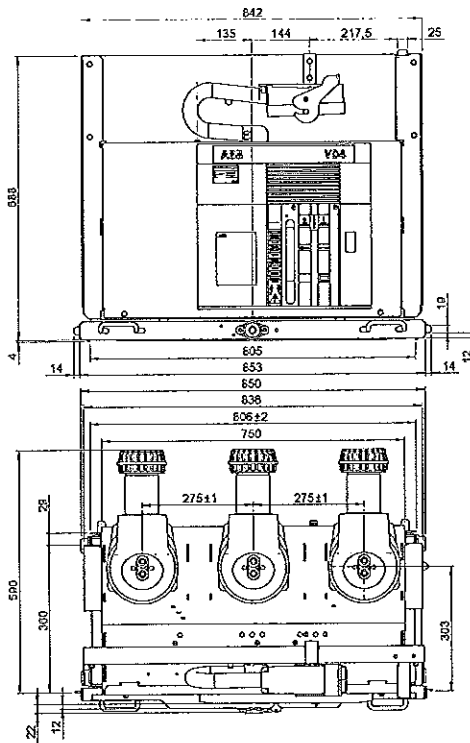

Withdrawable circuit-breakers for UniGear ZS1 switchgear

VD4/P	
TN	1VCD003446
Ur	12 kV
	17.5 kV
Ir	2500 A
Isc	50 kA

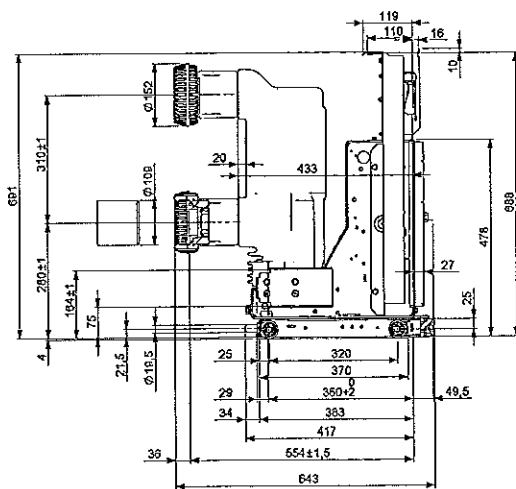
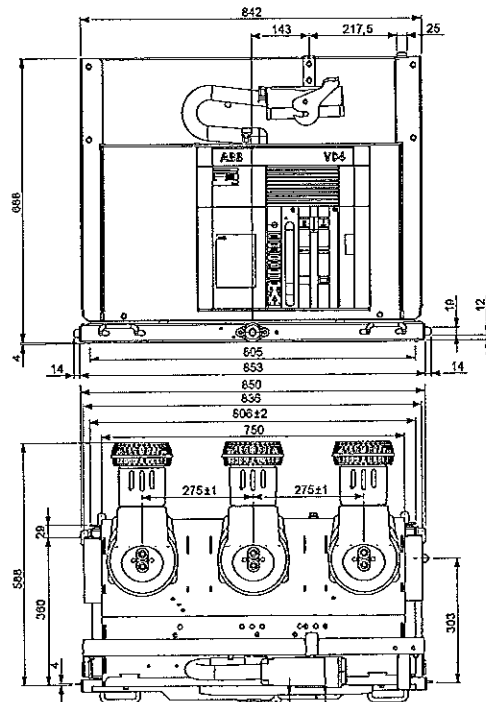

# 4. Overall dimensions

## Withdrawable circuit-breakers for UniGear ZS1 switchgear

VD4/P	
TN	1VCD000153
Ur	12 kV
	17.5 kV
Ir	3150 A (*)
Isc	40 kA

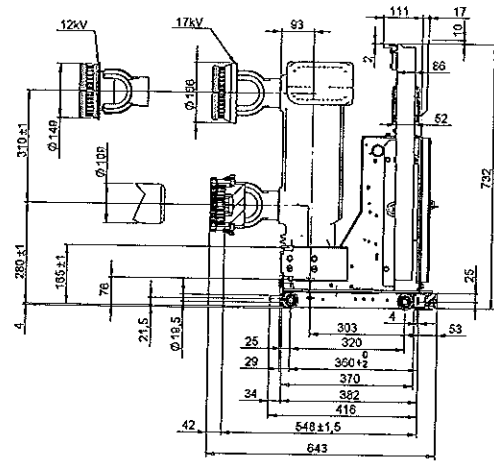
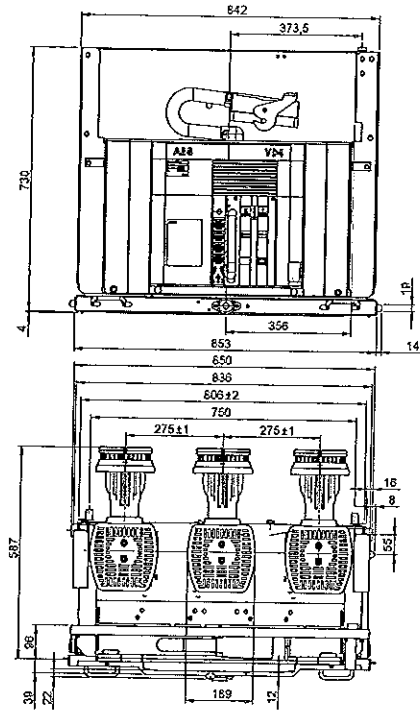

(\*) 4000 A with forced ventilation.

## Withdrawable circuit-breakers for UniGear ZS1 switchgear

VD4/P	
TN	1VCD003447
Ur	12 kV
	17.5 kV
Ir	3150 A (*)
Isc	50 kA

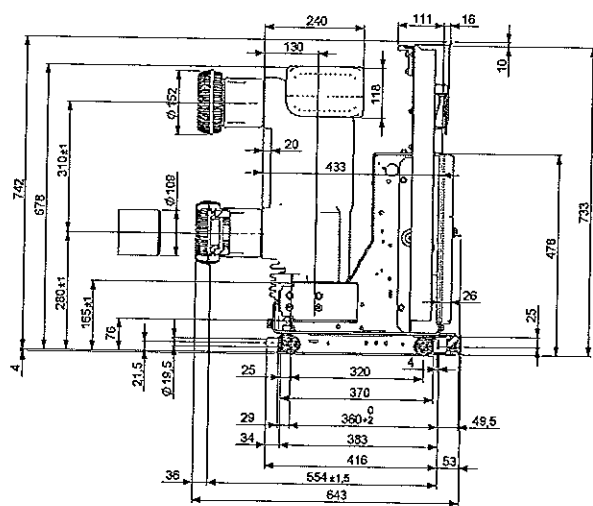
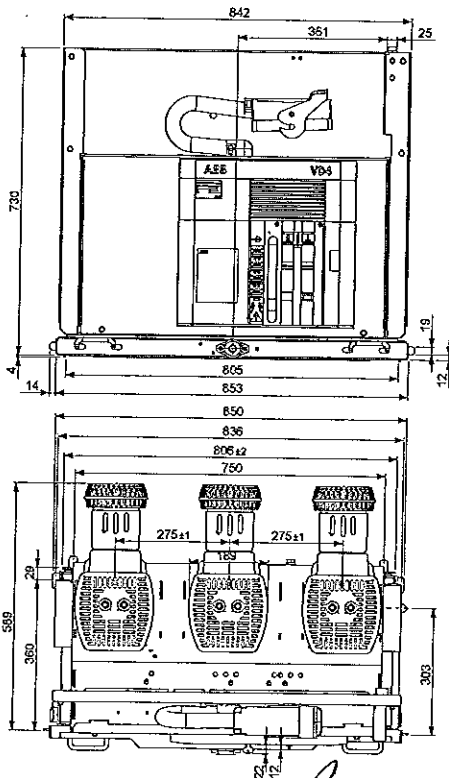

(\*) 4000 A with forced ventilation.



# 4. Overall dimensions

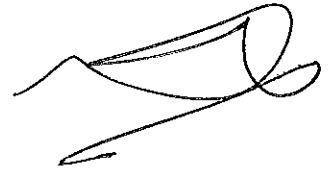

Withdrawable circuit-breakers for UniGear ZS1 switchgear

VD4/P	
TN	7414
Ur	24 kV
Ir	630 A
	1250 A
Isc	16 kA
	20 kA
	25 kA

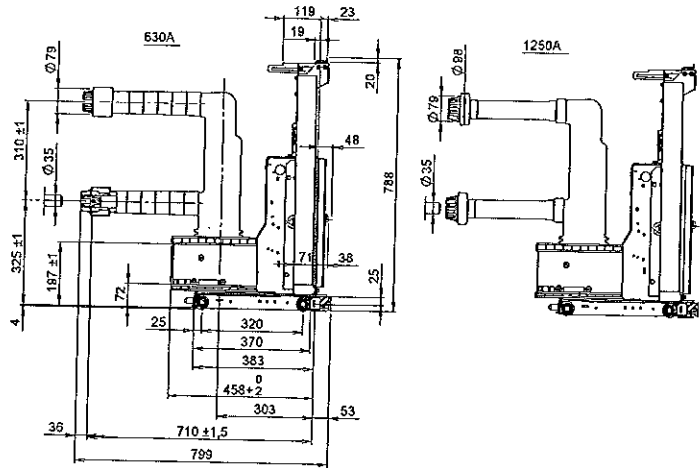
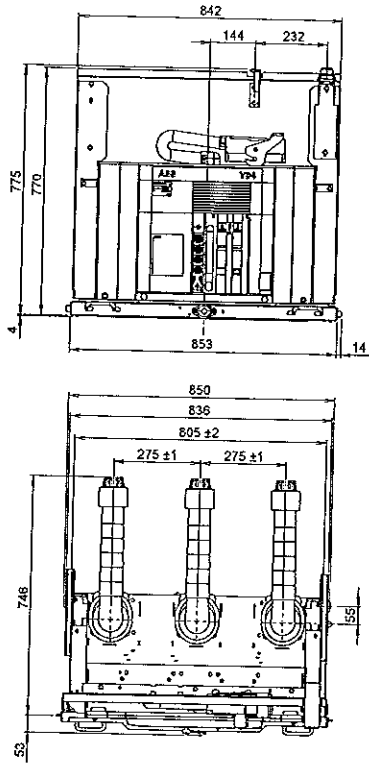

Withdrawable circuit-breakers for UniGear ZS1 switchgear and PowerCube PB4 modules

VD4/P	
TN	1VCD000173
Ur	24 kV
Ir	1250 A
Isc	31.5 kA

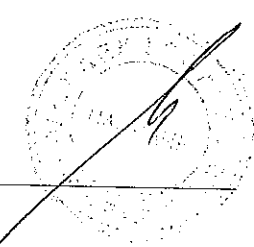
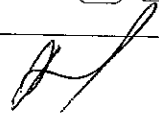
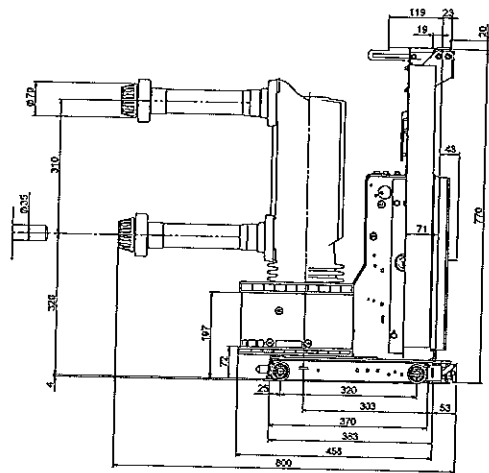
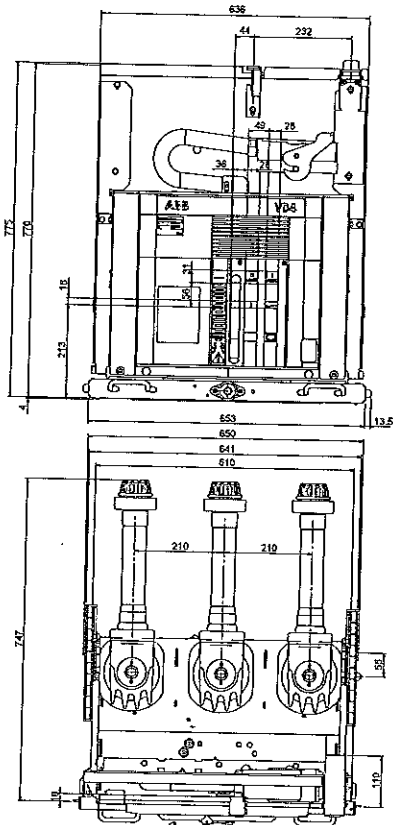



# 4. Overall dimensions

## Withdrawable circuit-breakers for UniGear ZS1 switchgear

VD4/P	
TN	1VCD000177
Ur	24 kV
	3150 A
Isc	31.5 kA

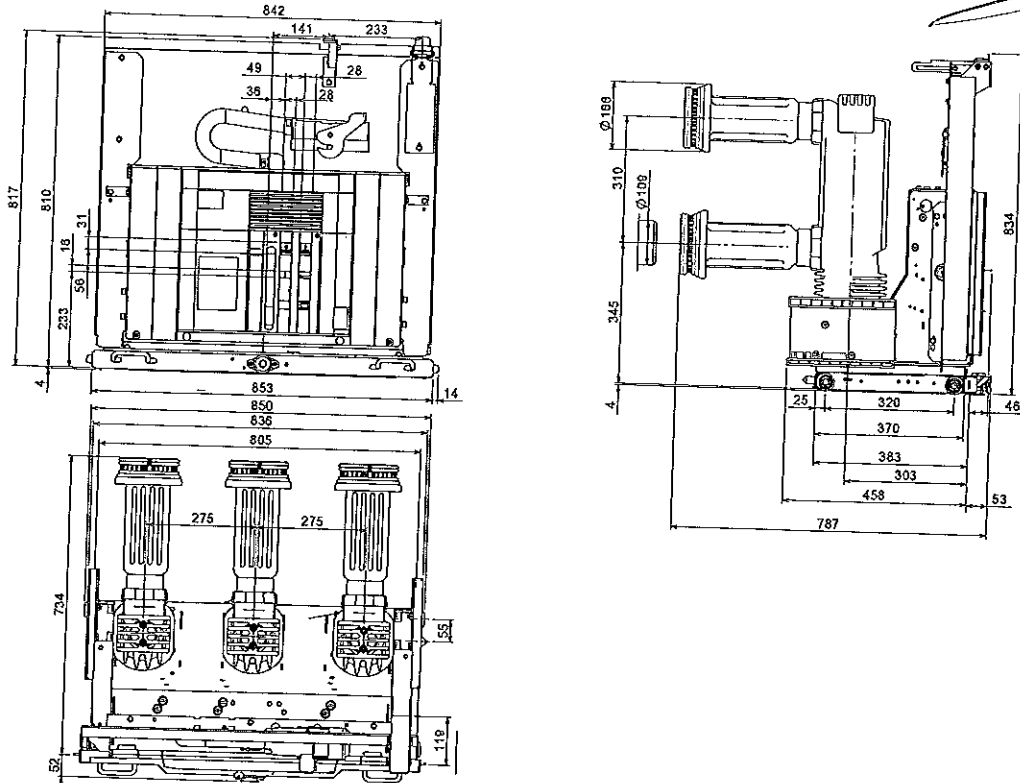

## Withdrawable circuit-breakers for UniGear ZS2 switchgear

VD4/W	
TN	1VYN300901-KG
Ur	36 kV
	1250 A
	1600 A
Ir	2000 A
	2500 A (*)
	20 kA
Isc	25 kA
	31.5 kA

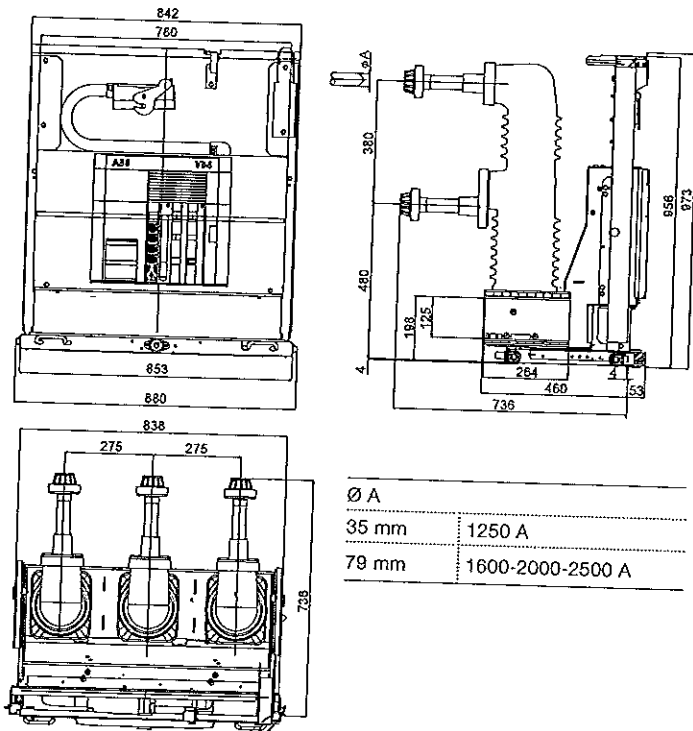

Ø A	
35 mm	1250 A
79 mm	1600-2000-2500 A

(\*) The rated uninterrupted current of 2500 A is guaranteed with forced ventilation.



Withdrawable circuit-breakers for ZS8.4 switchgear

VD4/Z8	
TN	1VCD000092
Ur	12 kV
Ir	630 A
Isc	20 kA
	25 kA

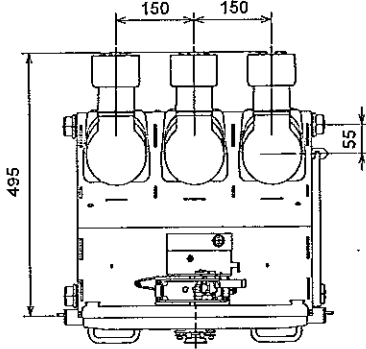
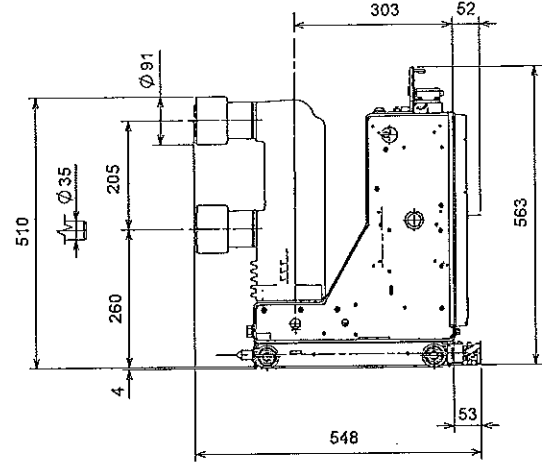
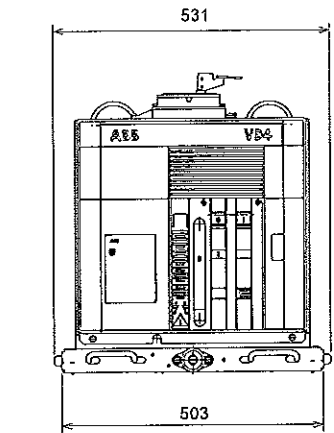

Withdrawable circuit-breakers for ZS8.4 switchgear

VD4/Z8	
TN	1VCD000137
Ur	12 kV
Ir	1250 A
Isc	20 kA
	25 kA

VD4/Z8	
TN	1VCD000137
Ur	17.5 kV
Ir	630 A
Isc	20 kA
	25 kA

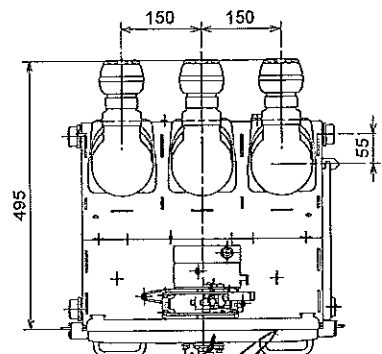
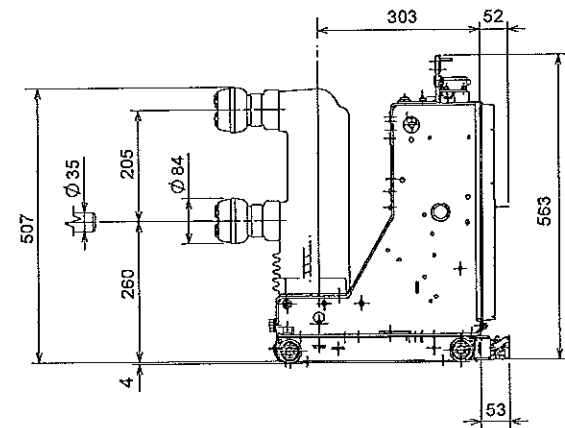
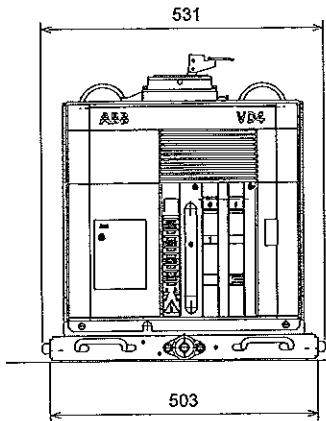



Withdrawable circuit-breakers for ZS8.4 switchgear

VD4/Z8	
TN	1VCD000138
Ur	24 kV
Ir	1250 A
Isc	16 kA
	20 kA
	25 kA

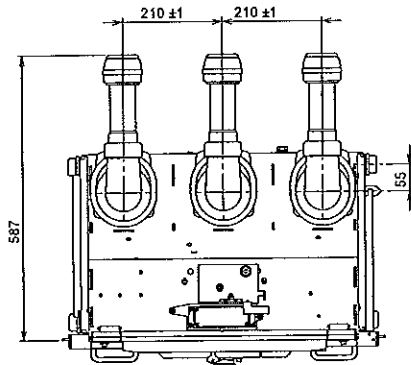
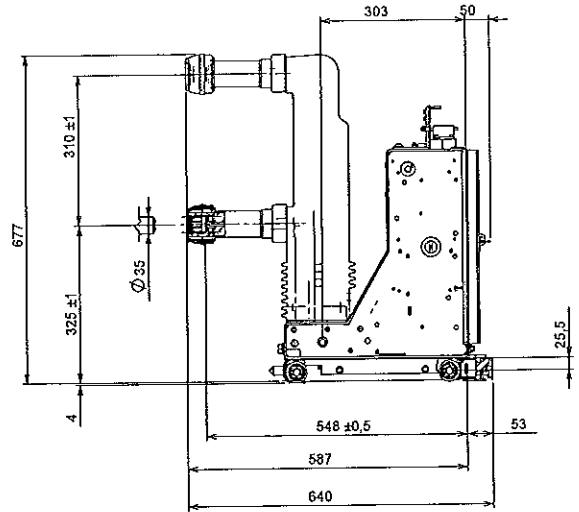
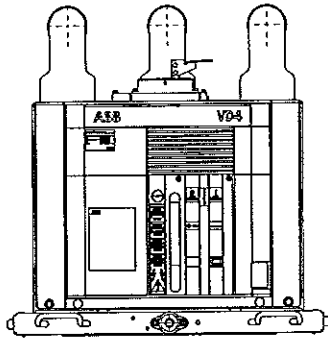

Withdrawable circuit-breakers for ZS8.4 switchgear

VD4/ZT8	
TN	1VCD000134
Ur	12 kV
Ir	1250 A
Isc	20 kA
	25 kA

VD4/ZT8	
TN	1VCD000134
Ur	17.5 kV
Ir	630 A
Isc	20 kA
	25 kA

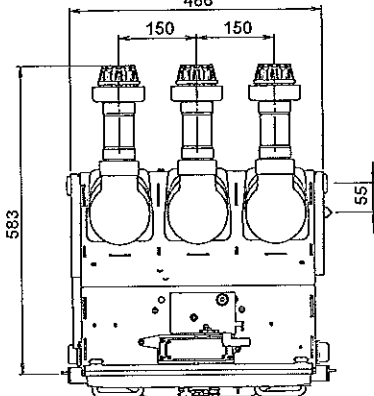
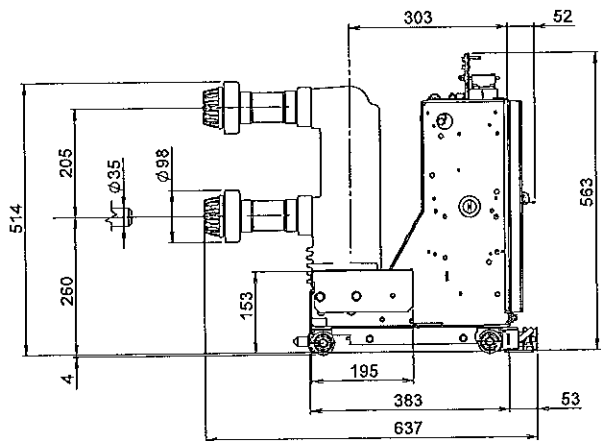
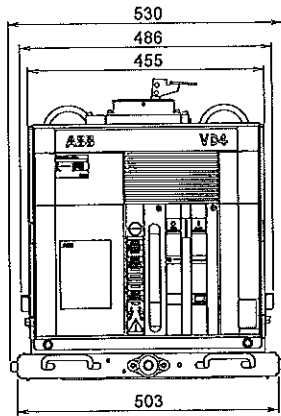

# 4. Overall dimensions

Withdrawable circuit-breakers for ZS8.4 switchgear

VD4/ZT8	
TN	1VCD000090
Ur	24 kV
Ir	630 A
Isc	16 kA
	20 kA
	25 kA

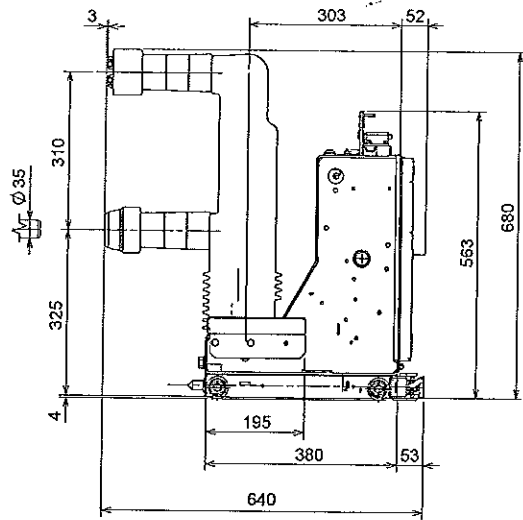
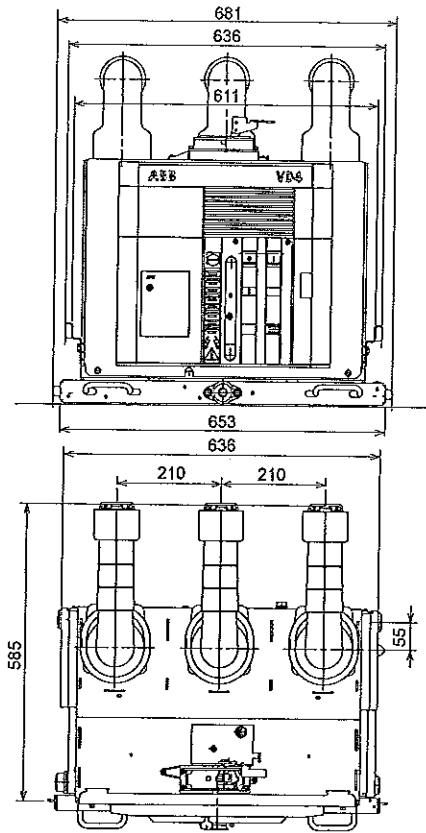

Withdrawable circuit-breakers for ZS8.4 switchgear

VD4/ZT8	
TN	1VCD000136
Ur	24 kV
Ir	1250 A
Isc	16 kA
	20 kA
	25 kA

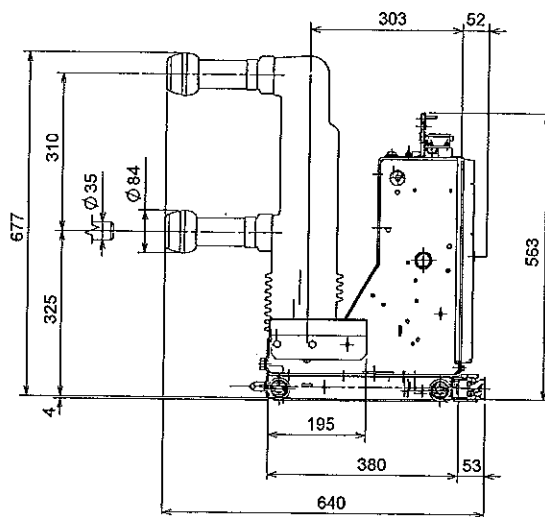
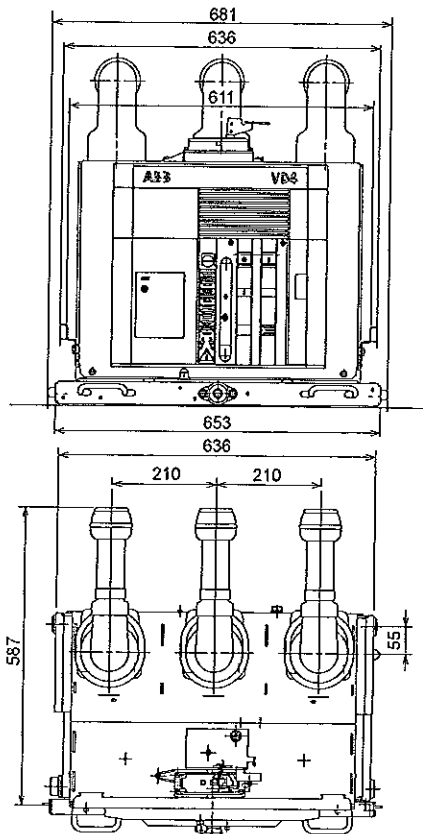

Withdrawable circuit-breakers for ZS8.4 switchgear

VD4/ZS8	
TN	1VCD000091
Ur	12 kV
Ir	630 A
Isc	20 kA
	25 kA

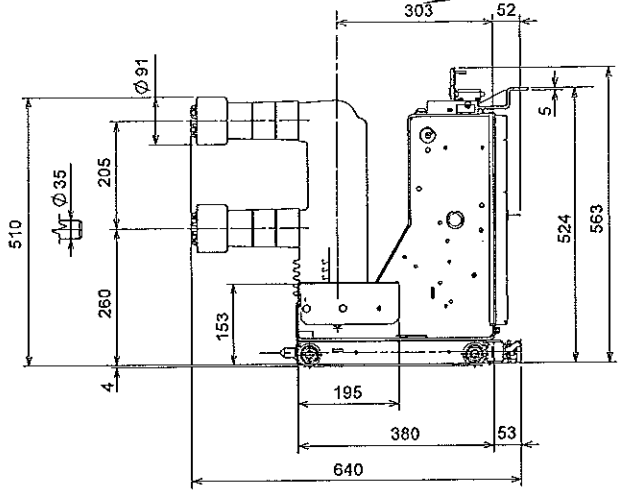
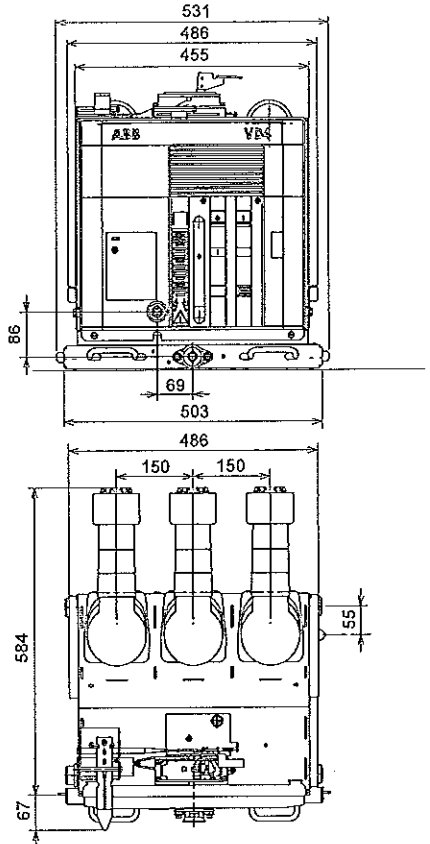

Withdrawable circuit-breakers for ZS8.4 switchgear

VD4/ZS8	
TN	1VCD000133
Ur	12 kV
Ir	1250 A
Isc	20 kA
	25 kA

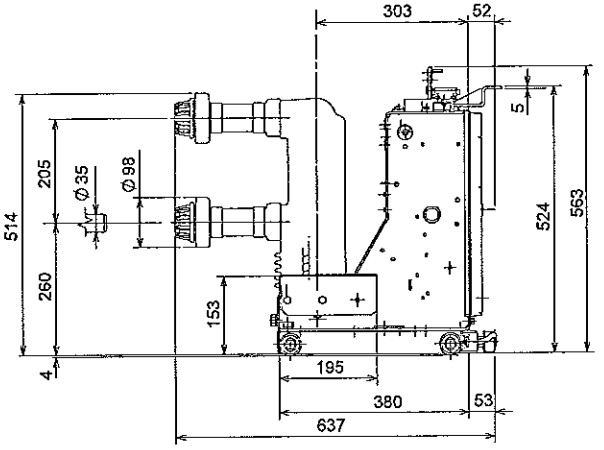
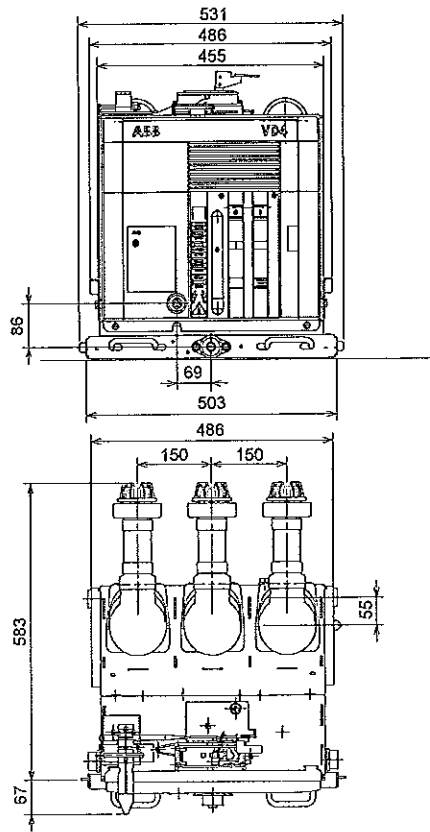

# 4. Overall dimensions

Withdrawable circuit-breakers for ZS8.4 switchgear

VD4/ZS8	
TN	1VCD000088
Ur	24 kV
Ir	630 A
	16 kA
Isc	20 kA
	25 kA

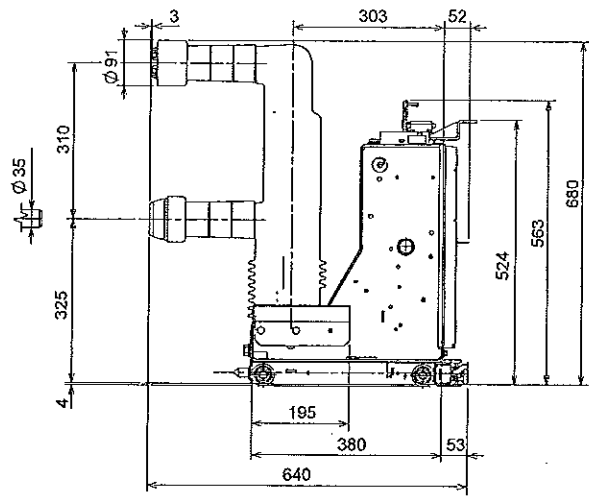
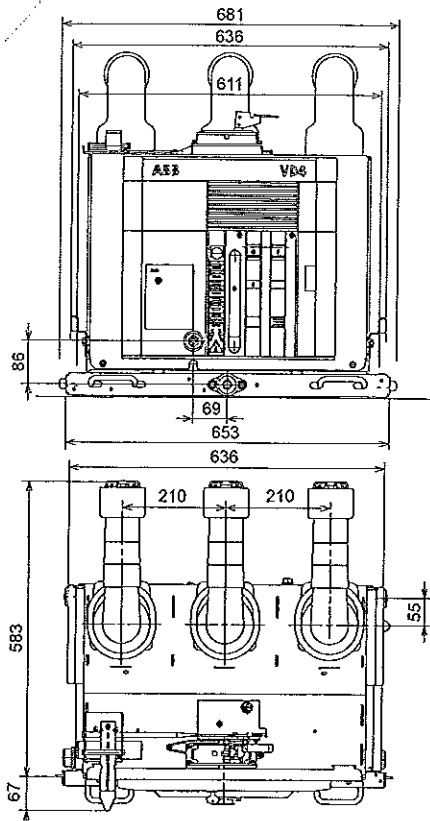

Withdrawable circuit-breakers for ZS8.4 switchgear

VD4/ZS8	
TN	1VCD000135
Ur	24 kV
Ir	1250 A
	16 kA
Isc	20 kA
	25 kA

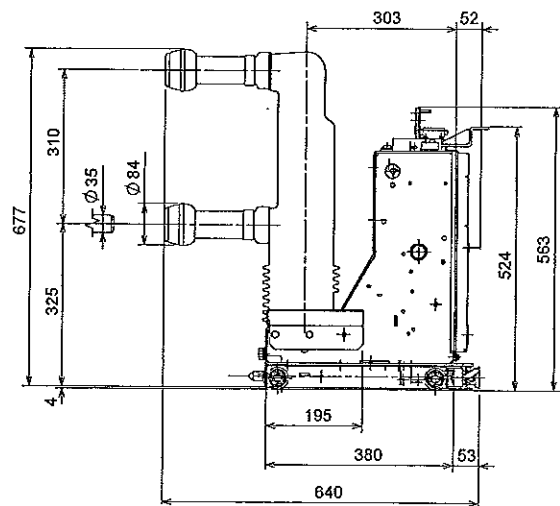
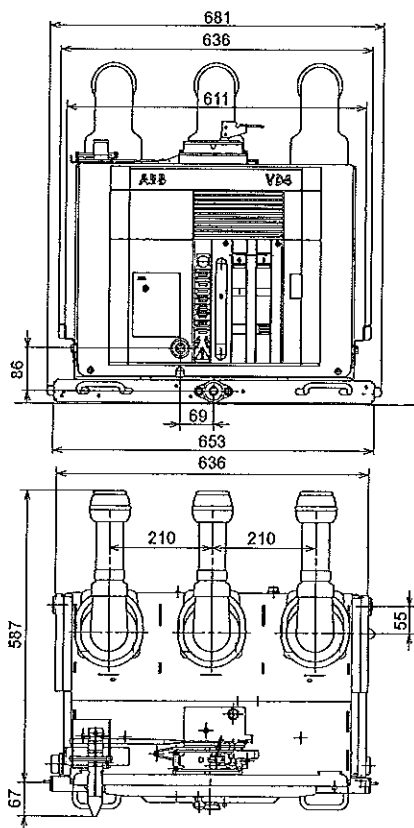

Withdrawable circuit-breakers for UniSwitch (CBW) and UniMix (P1/E) switchgear

VD4/US	
TN	1VCD000047
Ur	24 kV
Ir	630 A
	1250 A
Isc	16 kA
	20 kA
	25 kA

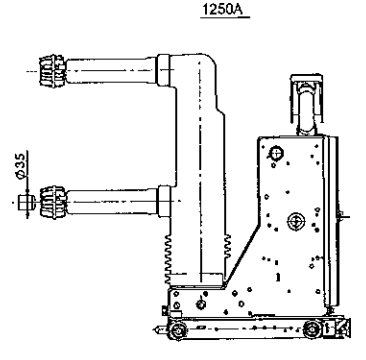
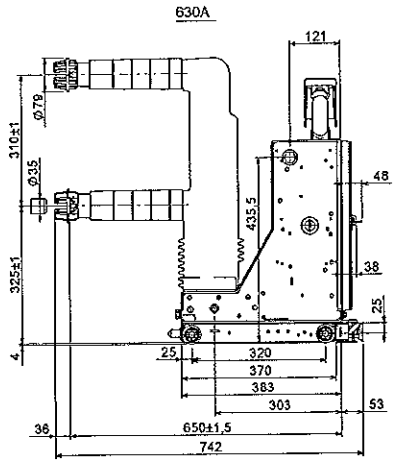
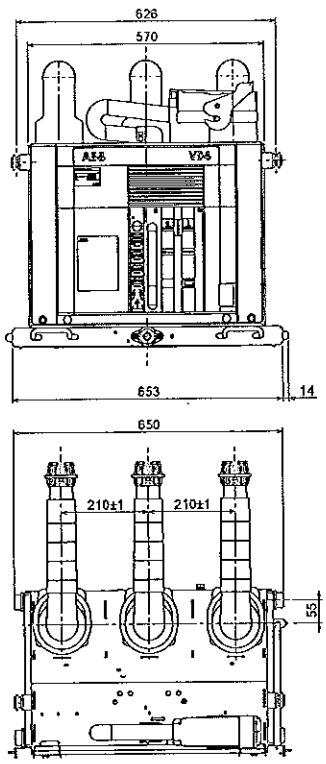

Withdrawable circuit-breakers for UniSec (WBC e WBS) switchgear

VD4/Sec	
TN	1VCD000190
Ur	24 kV
Ir	630 A
	1250 A
Isc	16 kA
	20 kA

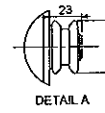
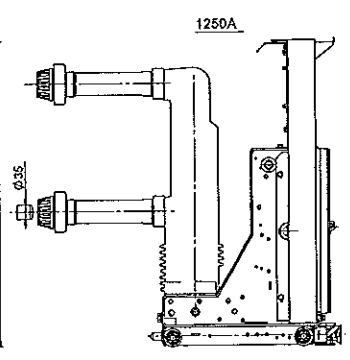
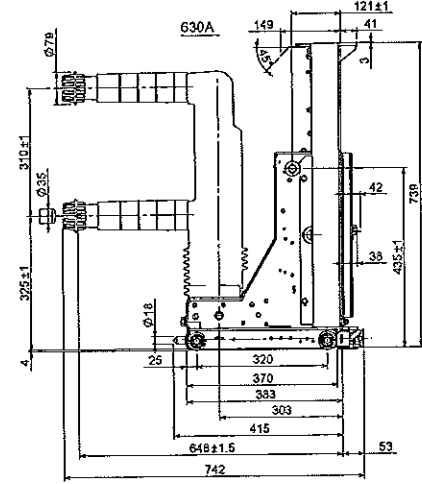
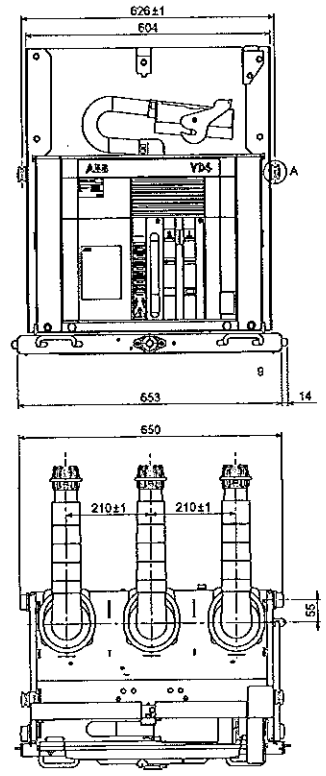

# 5. Electric circuit diagram

## State of operation represented

The diagrams shows the following conditions:

- Circuit-breaker open and connected (only withdrawable circuit-breaker)
- Circuits de-energized
- Closing springs discharged

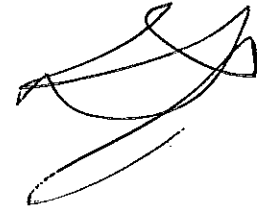

## Graphical symbols for electric diagrams

	Thermal effect		Mass, frame		Capacitor (general symbol)		Passing make contact closing momentarily during release
	Electromagnetic effect		Conductors in shielded cable (two conductors shown)		Motor (general symbol)		Closing position contact (limit switch)
	Timing		Connection of conductors		Rectifier with two half-waves (bridge)		Opening position contact (limit switch)
	Pushbutton control		Terminal or clamp		Make contact		Power circuit-breaker with automatic opening
	Key control		Socket and plug (female and male)		Break contact		Control coil (general symbol)
	Earth (general symbol)		Resistor (general symbol)		Change-over break before make contact		Lamp (general symbol)

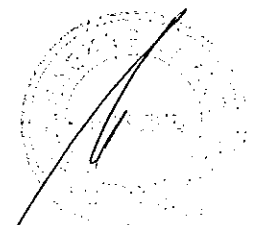
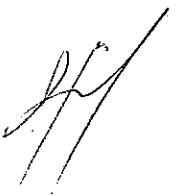



# Electric circuit diagram of fixed circuit-breakers 12 .. 24 kV 1VCD 400046

The electric circuit diagram given in this section regards the fixed circuit-breakers 12 .. 24 kV.

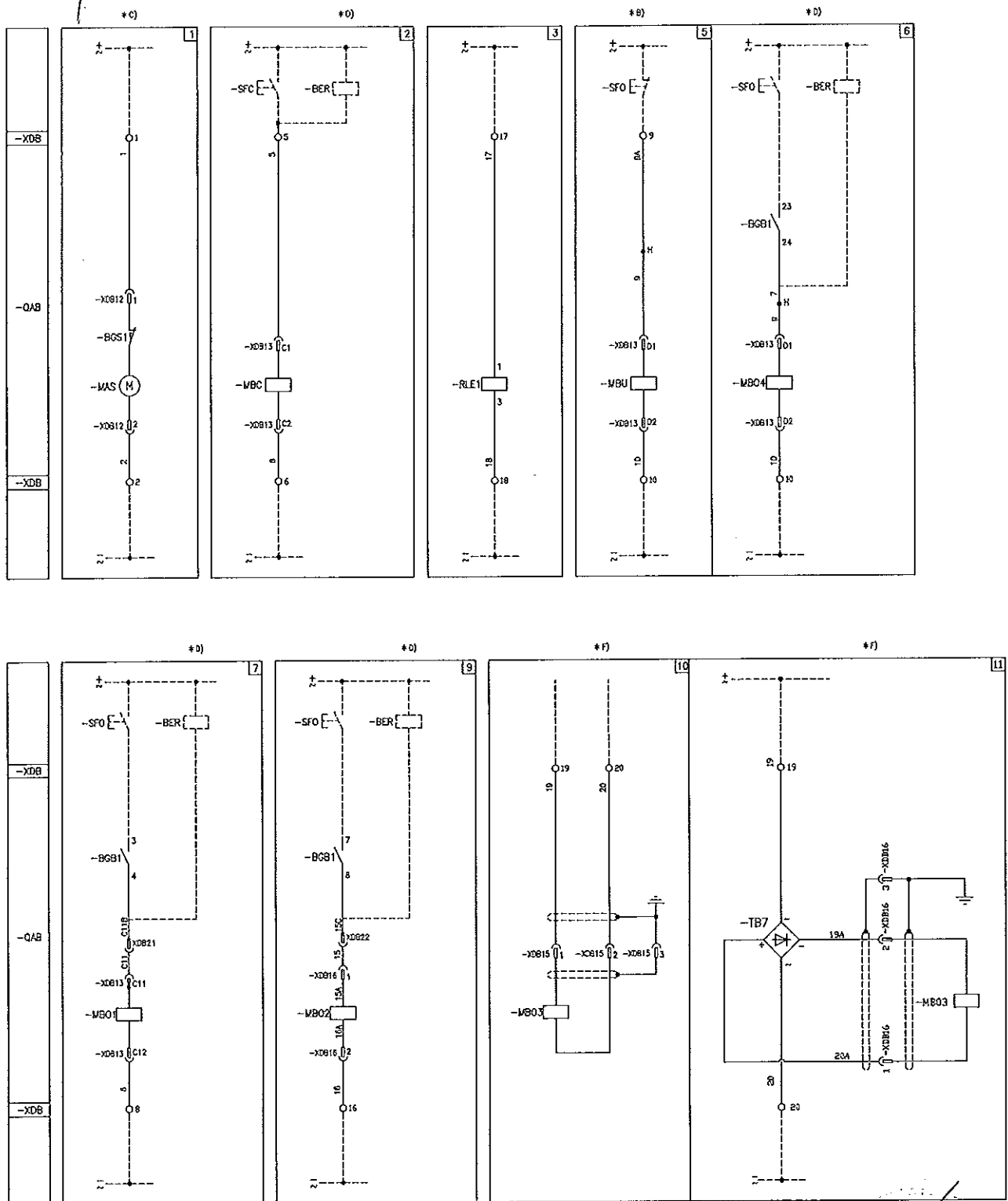

# 5. Electric circuit diagram

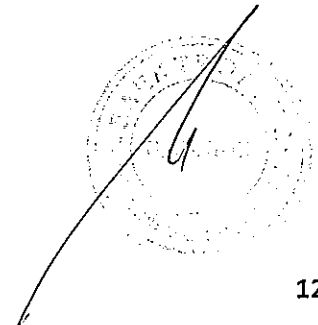
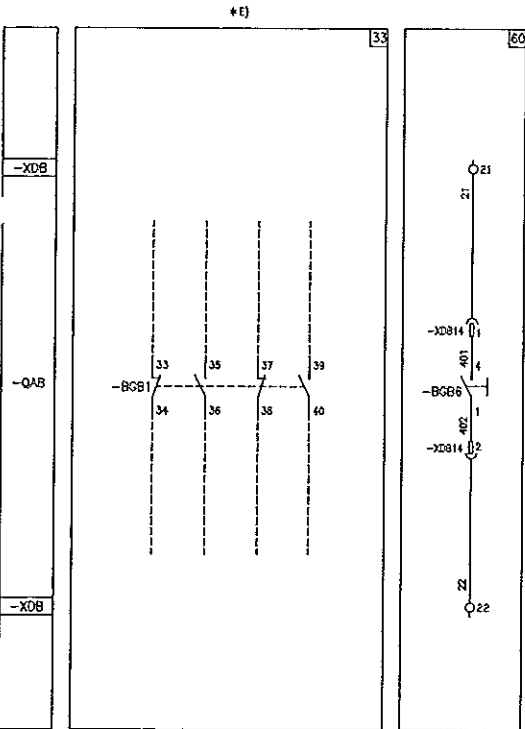
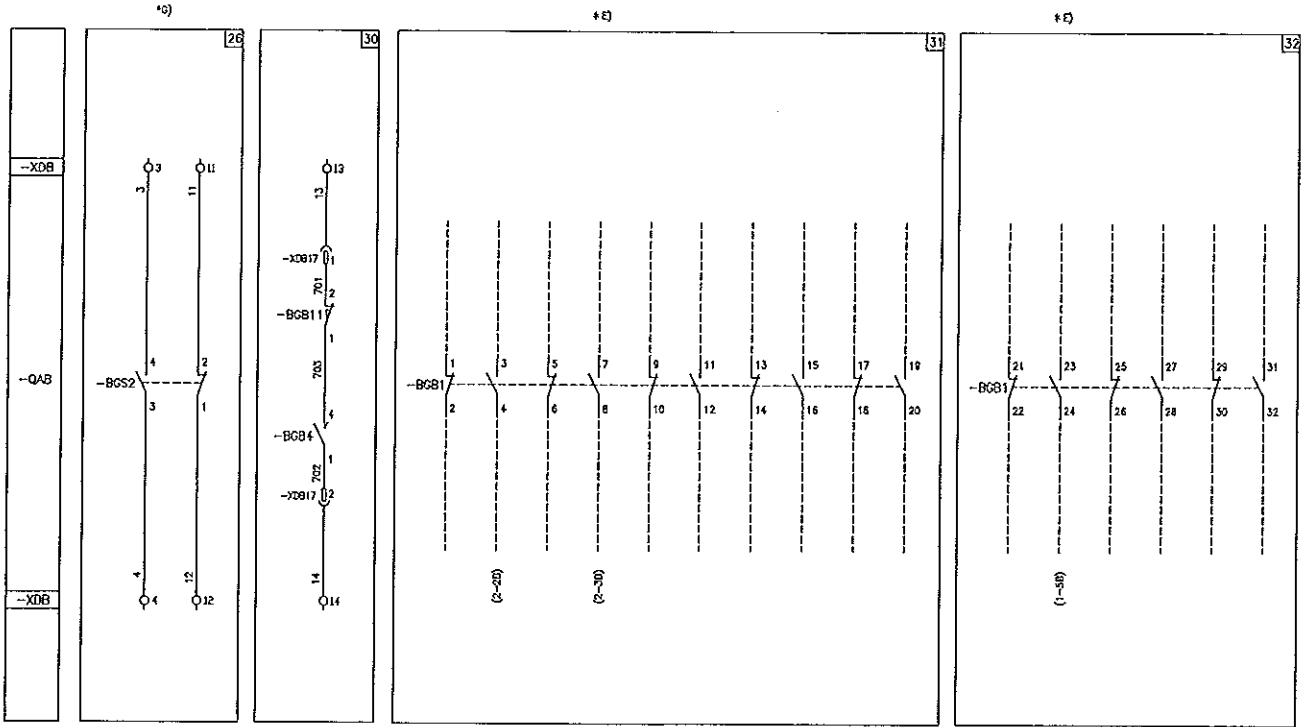
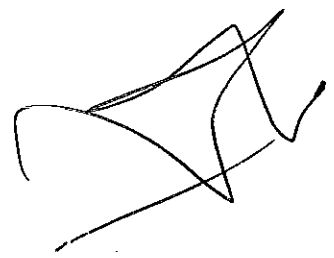

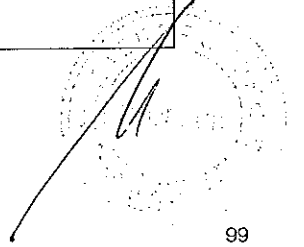
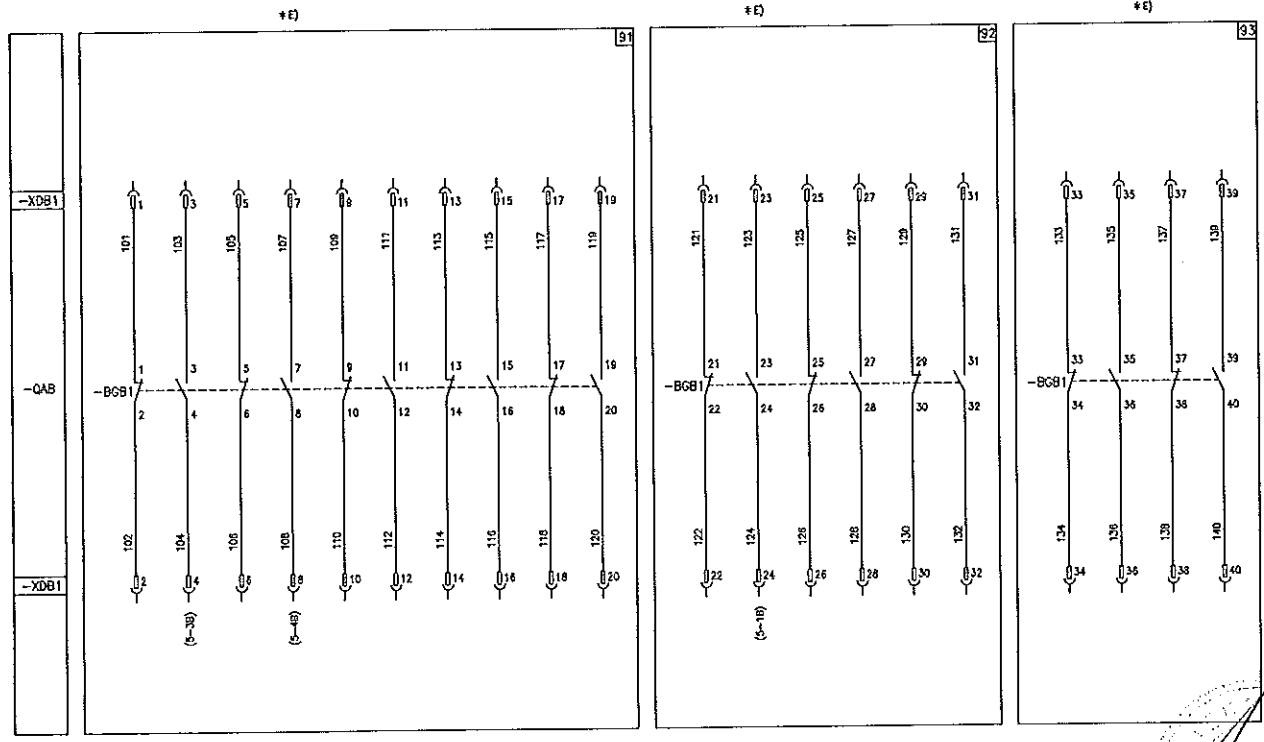
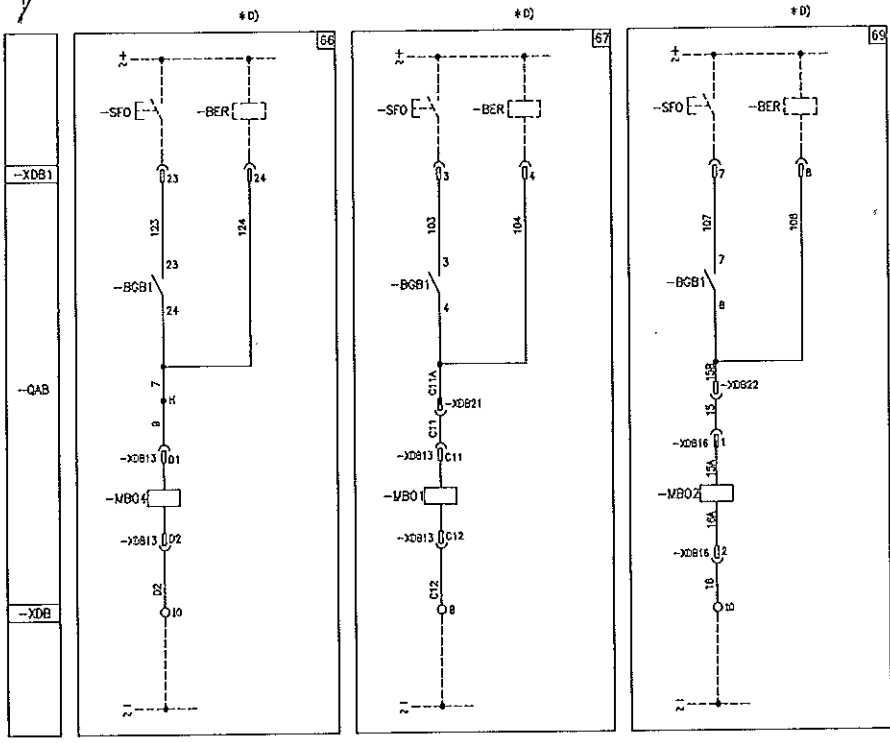
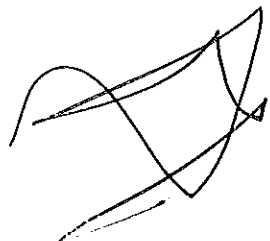
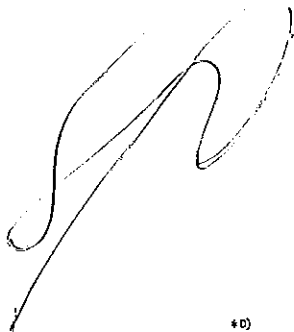

## 5. Electric circuit diagram

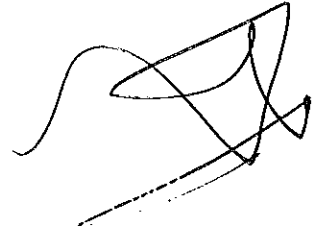

Caption	Description of the figures
□ = Figure number of the diagram.	Fig. 1 = Circuit of motor for loading closing springs (see note C).
* = See note indicated by the letter.	Fig. 2 = Shunt closing release (anti-pumping is achieved mechanically), (see note D).
-BER = SOR Test Unit device for monitoring continuity of shunt opening and closing release winding (see note D)	Fig. 3 = Locking magnet. Mechanically inhibits circuit-breaker closing if de-energized. Consumption can be limited by connecting a delayed operation enabling pushbutton in series.
-BGB1 = Auxiliary contacts of circuit-breaker.	Fig. 5 = Instantaneous undervoltage release (see note B).
-BGB4 = Auxiliary let-through contact of circuit-breaker with momentary closing during circuit-breaker opening.	Fig. 6, 66 = Circuit of third shunt opening release with possibility of continuous control of winding (see note D).
-BGB6 = Contact for electrical signalling of undervoltage release de-energized.	Fig. 7, 67 = Circuit of first shunt opening release with possibility of continuous control of winding (see note D).
-BGB11 = Contact for cutting off electrical signal -BGB4 if opening operation is performed in the manual mode.	Fig. 9, 69 = Circuit of second shunt opening release with possibility of continuous control of winding (see note D).
-BGS1 = Limit contact of spring loading motor.	Fig. 10 = Opening solenoid for release outside circuit-breaker.
-BGS2 = Contact for signalling closing springs loaded-discharged.	Fig. 11 = Opening solenoid for release outside circuit-breaker with AC supply.
-MAS = Motor for loading closing springs (see note C).	Fig. 26 = Electrical signalling of closing springs loaded and discharged.
-MBC = Shunt closing release (see note D).	Fig. 30 = Auxiliary let-through contact of circuit-breaker with momentary closing during circuit-breaker opening.
-MBO1 = First shunt opening release (see note D).	Fig. 31, 91 = Available auxiliary contacts of circuit-breaker (see note E).
-MBO2 = Second shunt opening release (see note D).	Fig. 32, 92 = Available auxiliary contacts of circuit-breaker (see note E).
-MBO3 = Opening solenoid for release outside circuit-breaker (see note F).	Fig. 33, 93 = Available auxiliary contacts of circuit-breaker (see note E).
-MBO4 = Third shunt opening release (see note D).	Fig. 60 = Contact for electrical signalling of undervoltage release de-energized.
-MBU = Under-voltage release (see note B).	
-QAB = Circuit-breaker applications.	
-RLE1 = Locking magnet. Mechanically inhibits circuit-breaker closing if de-energized. (Consumption can be limited by connecting a delayed operation enabling pushbutton in series).	
-SFC = Pushbutton or contact for closing circuit-breaker.	
-SFO = Pushbutton or contact for opening circuit-breaker.	
-TB7 = Rectifier for release -MBO3.	
-XDB = Terminal box of circuit-breaker circuits.	
-XDB1 = Connector of circuit-breaker circuits.	
-XDB10, ...,17 = Connectors of applications.	

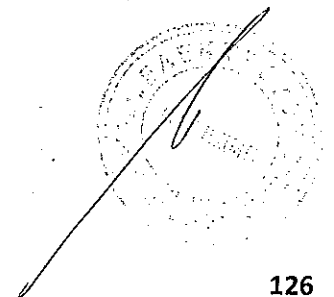



### Incompatibility

The circuits indicated in the following figures cannot be supplied at the same time in the same circuit-breaker:

5-6-66 7-67 9-69 31-91 32-92 33-93 10-11

### Notes

- A) The circuit-breaker is equipped solely with the applications specified in the order confirmation. Consult this catalogue for information about how to make out an order.
- B) The undervoltage release can be supplied for energizing with voltage derived from the supply side of the circuit-breaker or from an independent source. Circuit-breaker closing is only allowed when the release is energized (closing lock is obtained mechanically). If there is the same power supply for the shunt closing and under-voltage releases and the circuit-breaker must close automatically when auxiliary voltage returns, there must be a 50 ms delay between the under-voltage release's enabling instant and energizing of the shunt closing release.  
Incompatible with -MBO4.
- C) Check power of auxiliary circuit to find out whether several motors for loading the closing springs can be operated at the same time. To prevent excessive power draw, the springs must be loaded by hand before the auxiliary circuit is powered.
- D) The circuit for monitoring the continuity of the release windings must only be used for that purpose. The SOR Test Unit can be used for checking the continuity of the various different releases.  
-MBO4 incompatible with -MBU.  
-MBO4 not available for VD4 50 kA.

- E) When fig. 6 is required, contact -BGB1 (23-24) of fig.32 is not available.  
When fig. 7 is required, contact -BGB1 (3-4) of fig. 31 is not available.  
When fig. 9 is required, contact -BGB1 (7-8) of fig. 31 is not available.  
When fig. 32 is required, it is obligatory to supply the auxiliary contacts of fig. 31.  
When fig. 33 is required, it is obligatory to supply the auxiliary contacts of fig. 32.  
When fig. 66 is required, contact -BGB1 (23-24) of fig. 92 is not available.  
When fig. 67 is required, contact -BGB1 (3-4) of fig. 91 is not available.  
When fig. 69 is required, contact -BGB1 (7-8) of fig. 91 is not available.  
When fig. 92 is required, it is obligatory to supply the auxiliary contacts of fig. 91.  
When fig. 93 is required, it is obligatory to supply the auxiliary contacts of fig. 92.  
Figs. 33 and 93 are not available for VD4 50 kA.
- F) Figs. 10 and 11 are only available for VD4 up to 31.5 kA.
- G) The energizing voltage must be the same for both signals.

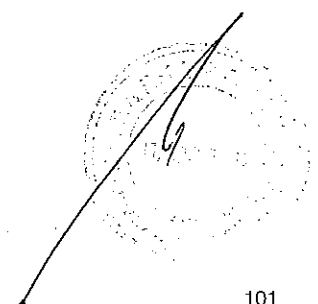

# 5. Electric circuit diagram

Electric circuit diagram of fixed circuit-breakers 36 kV 1VCD 400236

The electric circuit diagram given in this section regards the fixed circuit-breakers 36 kA.

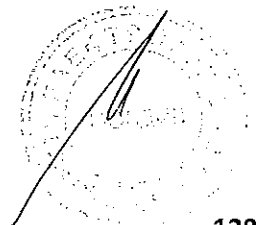
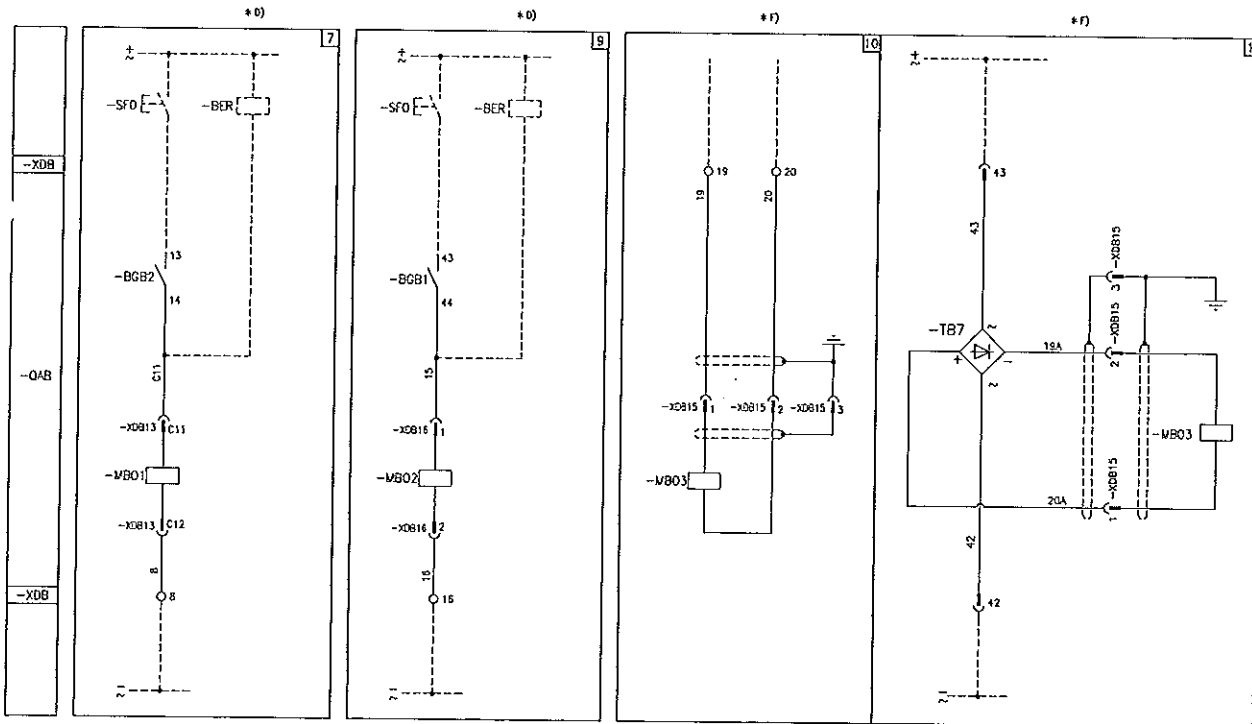
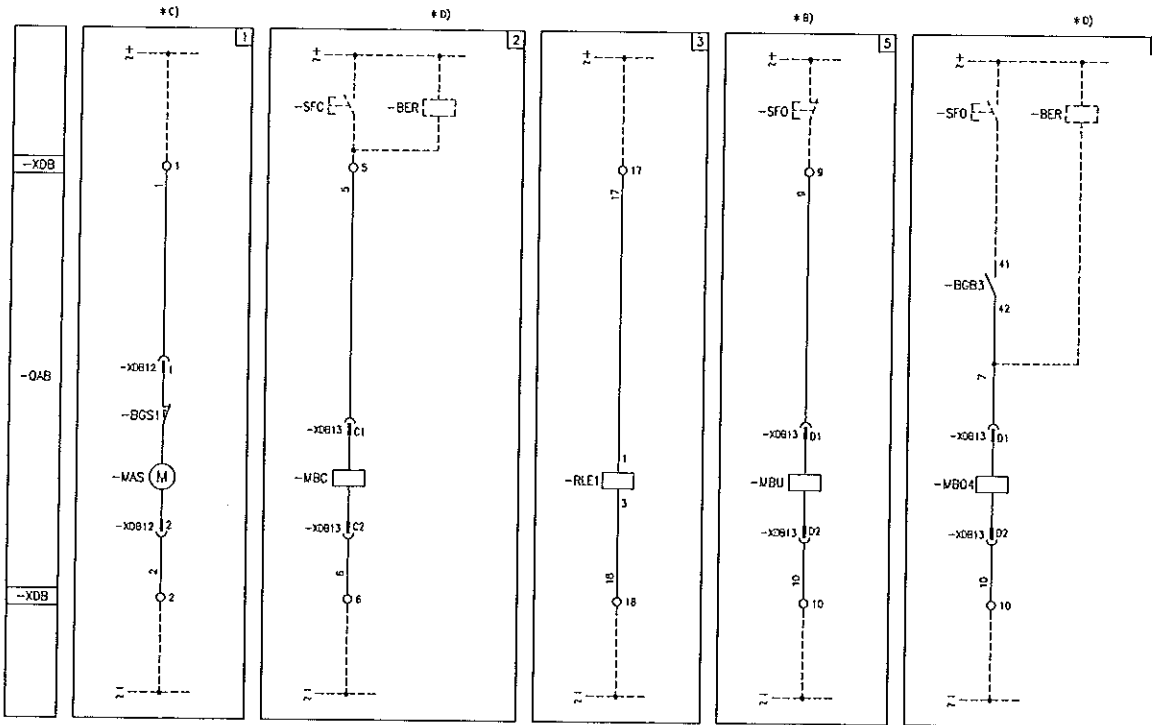
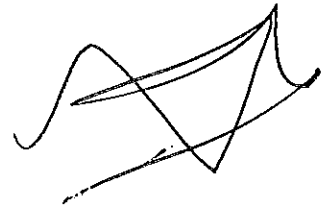

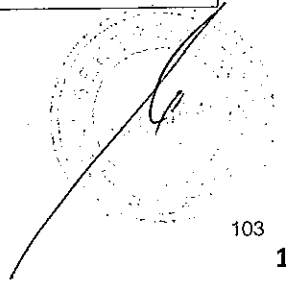
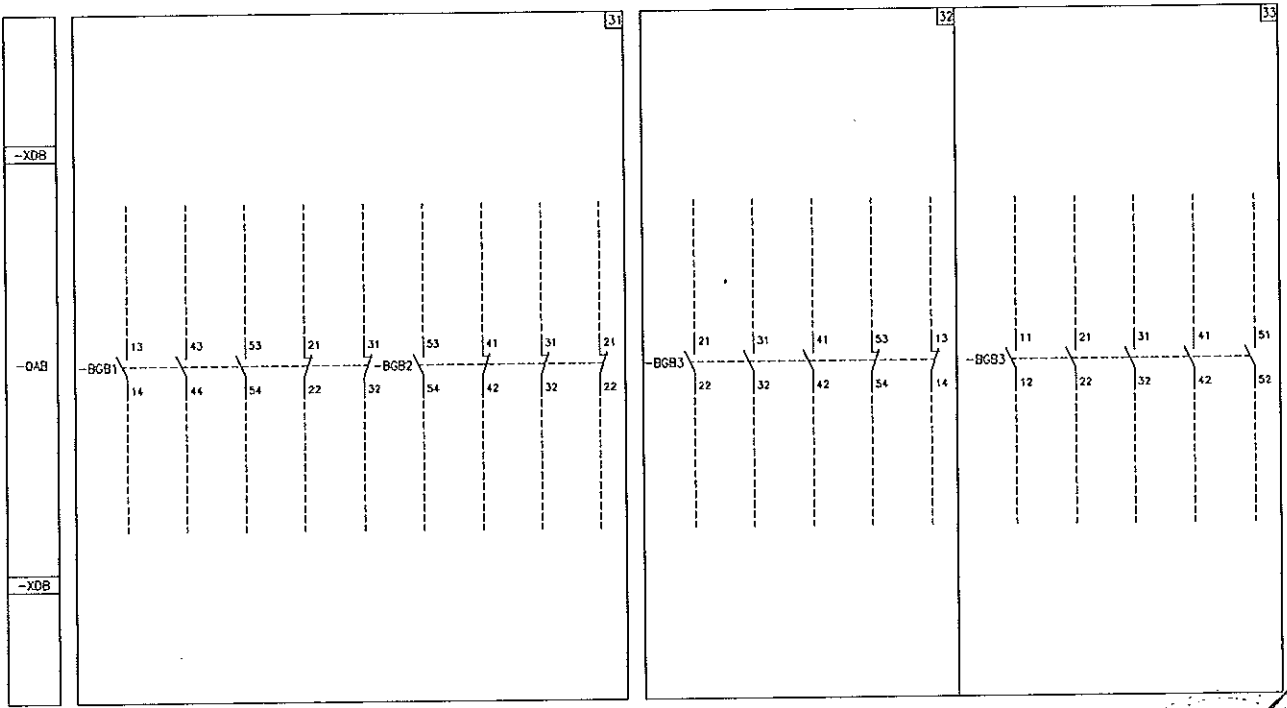
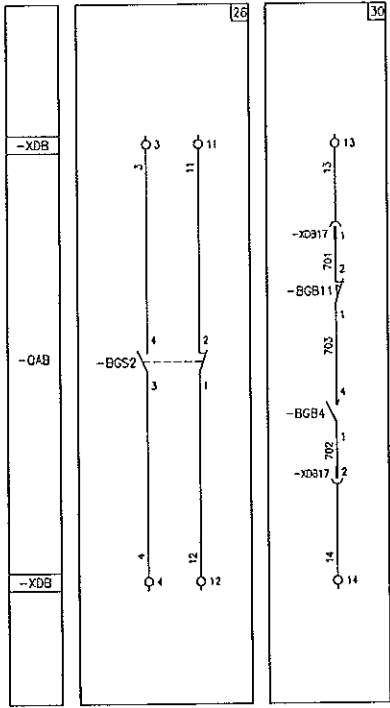
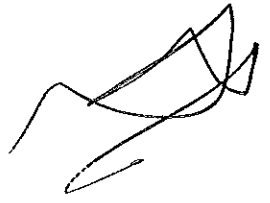

# 5. Electric circuit diagram

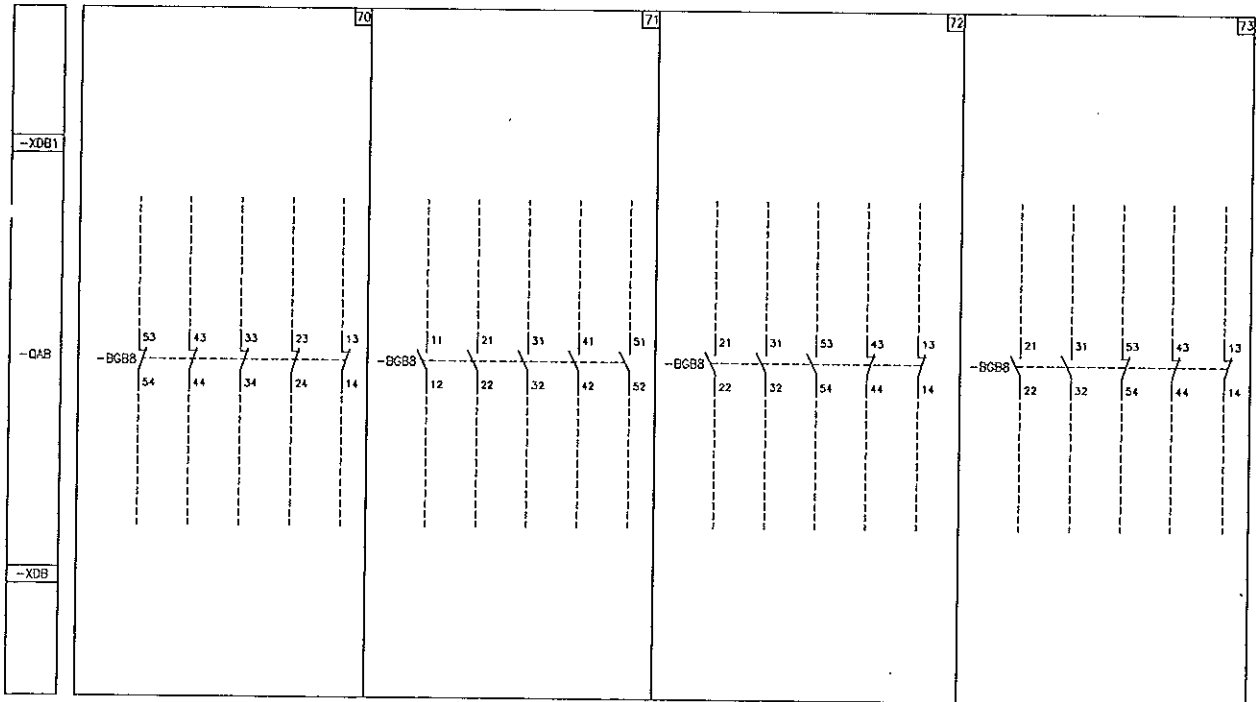
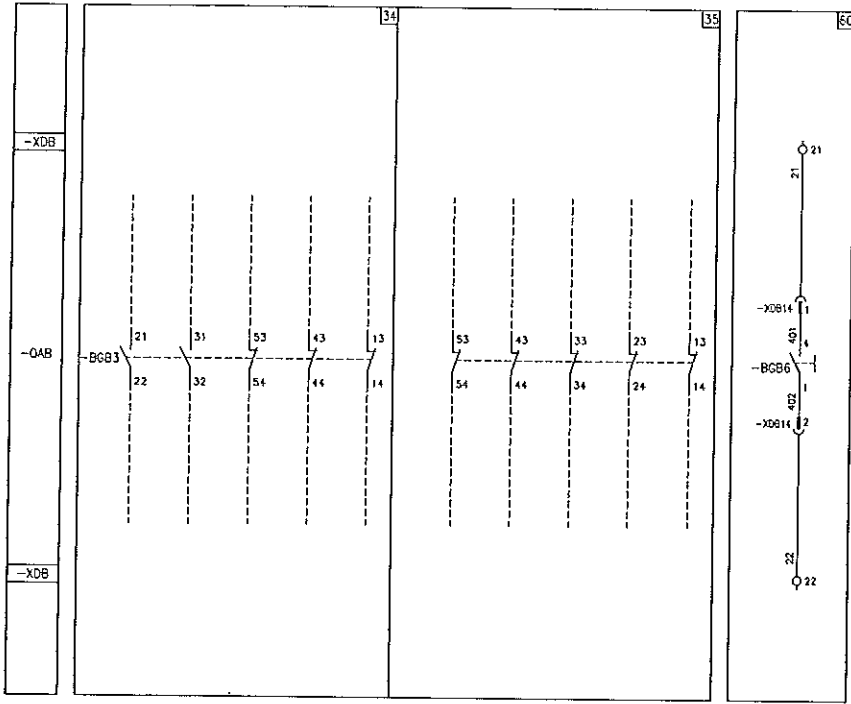
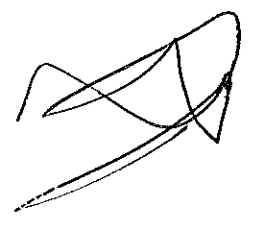



**Caption**

- = Figure number of the diagram.
- \* = See note indicated by the letter.
- BER = SOR Test Unit device for monitoring the continuity of the shunt opening and closing release winding (see note D)
- BGB1, 2, 3, 8 = Auxilliary contacts of circuit-breaker.
- BGB4 = Auxilliary let-through contact of circuit-breaker with momentary closing during circuit-breaker opening.
- BGB6 = Contact for electrical signalling of undervoltage release de-energized.
- BGB11 = Contact for cutting off electrical signal -BGB4 if opening operation is performed in the manual mode.
- BGS1 = Limit contact of spring loading motor.
- BGS2 = Contact for signalling closing springs loaded-discharged.
- MAS = Motor for loading closing springs (see note C).
- MBC = Shunt closing release (see note D).
- MBO1 = First shunt opening release (see note D).
- MBO2 = Second shunt opening release (see note D).
- MBO3 = Opening solenoid for release outside circuit-breaker.
- MBO4 = Third shunt opening release (see note D).
- MBU = Undervoltage release (see note B).
- QAB = Circuit-breaker applications.
- RLE1 = Locking magnet. Mechanically inhibits circuit-breaker closing if de-energized.  
(Consumption can be limited by connecting a delayed operation enabling pushbutton in series).
- SFC = Pushbutton or contact for closing circuit-breaker.
- SFO = Pushbutton or contact for opening circuit-breaker.
- TB7 = Rectifier for release -MBO3.
- XDB = Terminal box of circuit-breaker circuits.
- XDB10, ... ,17 = Connectors of applications

**Description of the figures**

- Fig. 1 = Circuit of motor for loading closing springs (see note C).
- Fig. 2 = Shunt closing release (anti-pumping is achieved mechanically), (see note D).
- Fig. 3 = Locking magnet. Mechanically inhibits circuit-breaker closing if de-energized Consumption can be limited by connecting a delayed pushbutton in series so as to enable the operation.
- Fig. 5 = Instantaneous undervoltage release (see note B).
- Fig. 6 = Circuit of third opening release with continuous control of winding (see note D).
- Fig. 7 = Circuit of first opening release with continuous control of winding (see note D).
- Fig. 9 = Circuit of second opening release with continuous control of winding (see note D).
- Fig. 10 = Opening solenoid for release outside circuit-breaker.
- Fig. 11 = Opening solenoid for release outside circuit-breaker with AC supply.
- Fig. 26 = Electrical signalling of closing springs loaded and discharged.
- Fig. 30 = Auxilliary let-through contact of circuit-breaker with momentary closing during circuit-breaker opening.
- Fig. 31 = Available auxilliary contacts of circuit-breaker.
- Fig. 32, ... , 35 = Available auxilliary contacts of circuit-breaker.
- Fig. 60 = Contact for electrical signalling of undervoltage release de-energized.
- Fig. 70, ... , 73 = Available auxilliary contacts of circuit-breaker.

## 5. Electric circuit diagram

### Incompatibility

The circuits indicated in the following figures cannot be supplied at the same time in the same circuit-breaker:

5-6 10-11 32-33-34-35 70-71 -72-73

### Notes

- A) Circuit-breaker is equipped solely with the applications specified in the order confirmation. Consult this catalogue for information about how to make out an order.
- B) The undervoltage release can be supplied for energizing with voltage derived from the supply side of the circuit-breaker or from an independent source.  
Circuit-breaker closing is only allowed when the release is energized (closing lock is obtained mechanically). If there is the same power supply for the shunt closing and under-voltage releases and the circuit-breaker must close automatically when auxiliary voltage returns, there must be a 50 ms delay between the under-voltage release's enabling instant and energizing of the shunt closing release.  
Incompatible with -MBO4.
- C) Check power of auxiliary circuit to find out whether several motors for loading the closing springs can be operated at the same time. To prevent excessive power draw, springs must be loaded by hand before auxiliary circuit is powered.
- D) The circuit for monitoring the continuity of the release windings must only be used for that purpose. The SOR Test Unit can be used for checking the continuity of the various different releases.
- E) When fig. 6 is required, contact -BGB3 (41-42) of fig. 32-33 is not available and fig. 34-35 cannot be supplied.  
When fig. 9 is required, contact -BGB1 (43-44) of fig. 31 is not available.
- F) Only available for 31.5 kA.





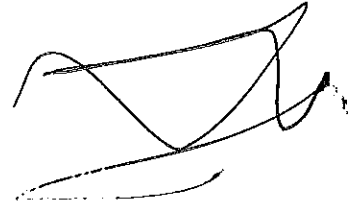
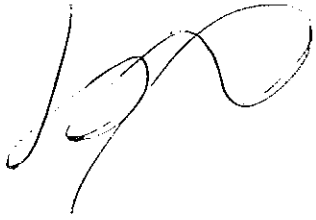

\*EJ

32

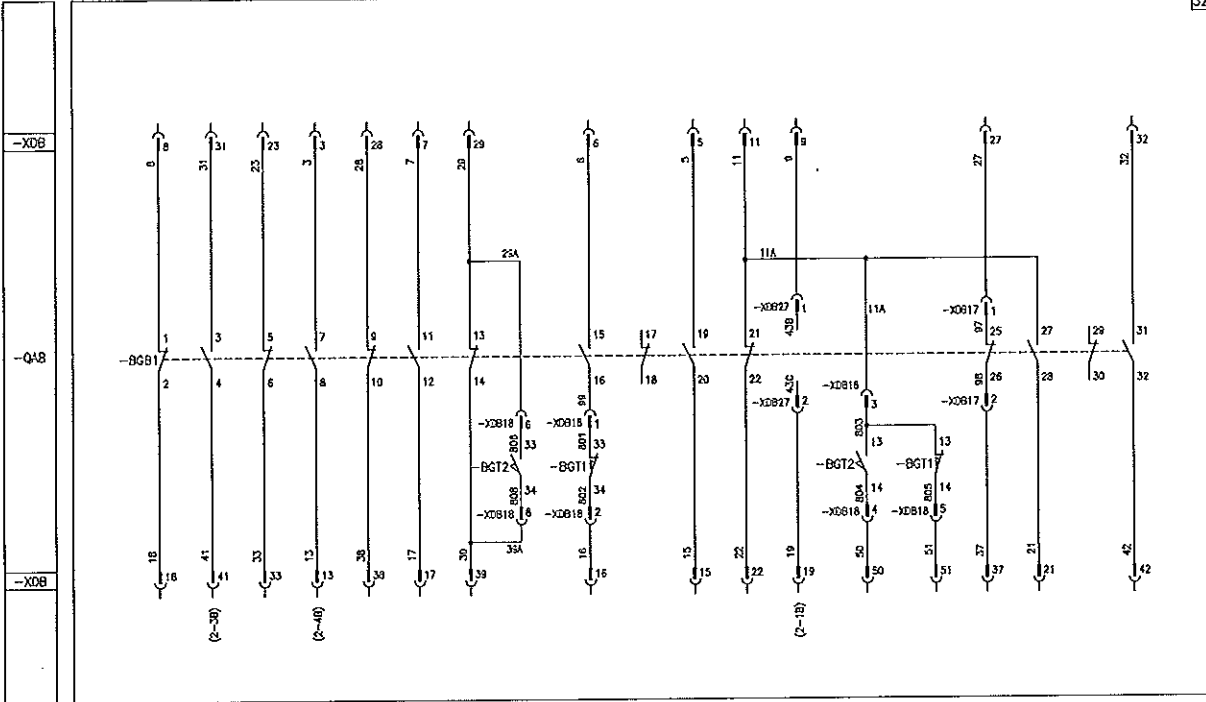

\*EJ

33

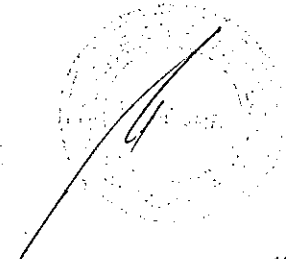
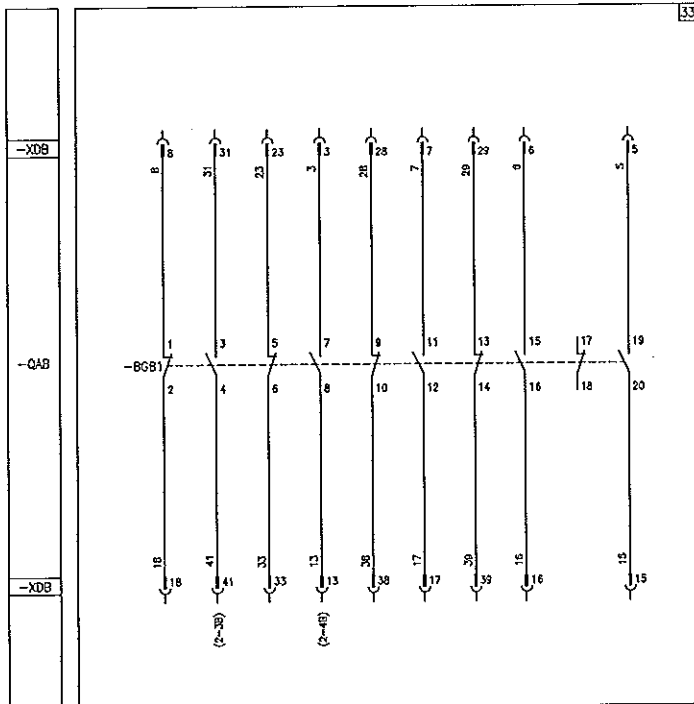

# 5. Electric circuit diagram

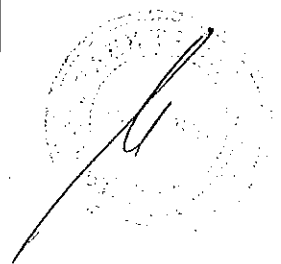
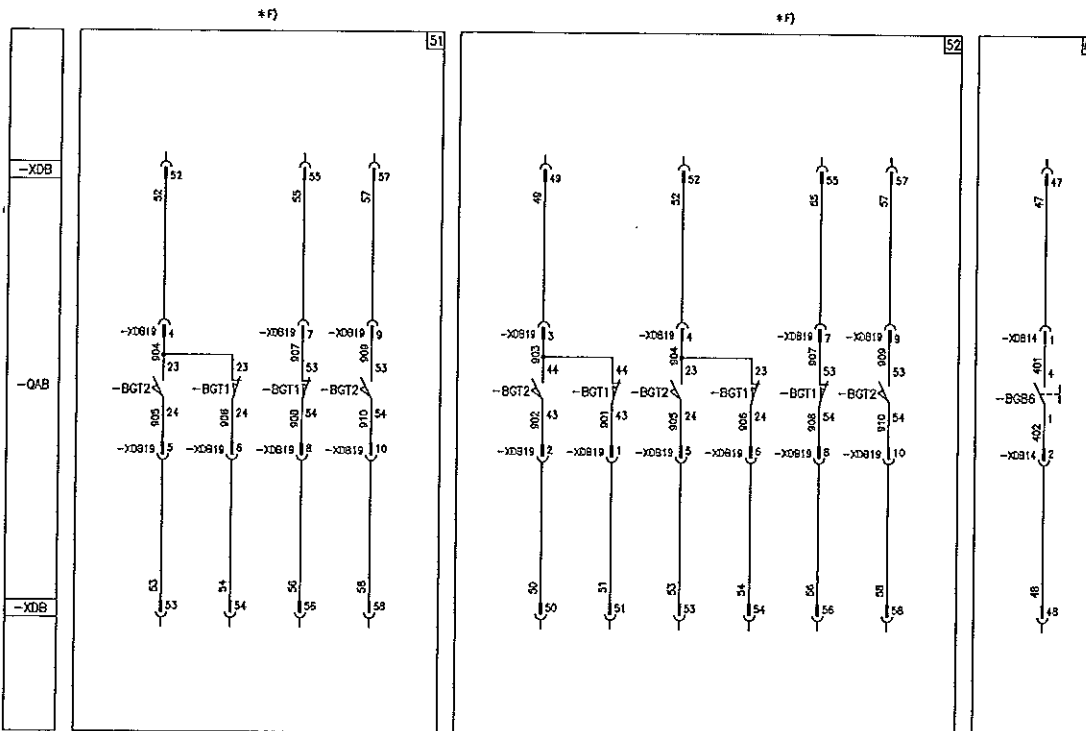
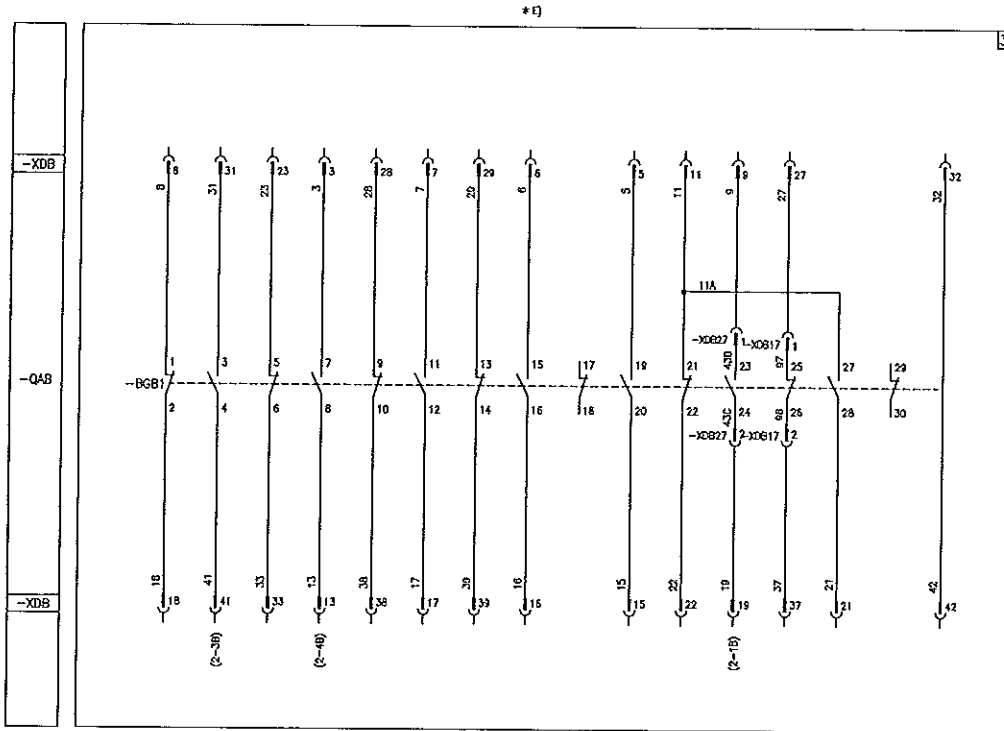
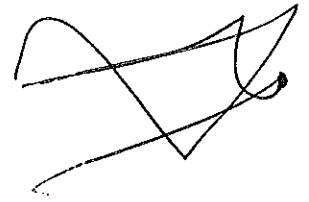

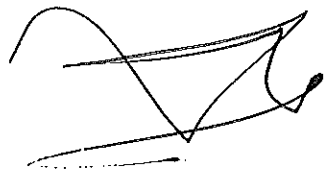

**Caption**

- = Figure number of the diagram.
- \* = See note indicated by the letter.
- BER = SOR Test Unit device for monitoring continuity of shunt opening and closing release winding (see note D)
- BGB1 = Auxiliary contacts of circuit-breaker.
- BGB4 = Auxiliary let-through contact of circuit-breaker with momentary closing during circuit-breaker opening.
- BGB6 = Contact for electrical signalling of undervoltage release de-energized.
- ( -BGB11 = Contact for cutting off electrical signal -BGB4 if opening operation is performed in the manual mode.
- BGD1 = Enclosure door position contact.
- BGS1 = Limit contact of spring loading motor.
- BGS2 = Contact for signalling closing springs loaded-discharged.
- BGT1 = Electrical signalling contacts for circuit-breaker in racked-in position (see note F)
- BGT2 = Electrical signalling contacts for circuit-breaker in isolated position (see note F).
- BGT3 = Circuit-breaker position contact, open during isolating travel.
- MAS = Motor for loading closing springs (see note C).
- MBC = Shunt closing release (see note D).
- MBO1 = First shunt opening release (see note D).
- MBO2 = Second shunt opening release (see note D).
- MBO3 = Opening solenoid for release outside circuit-breaker.
- ( -MBO4 = Third shunt opening release (see note D).
- MBU = Under-voltage release (see note B).
- QAB = Circuit-breaker applications.
- RLE1 = Locking magnet. Mechanically inhibits circuit-breaker closing if de-energized. (Consumption can be limited by connecting a delayed pushbutton in series so as to enable the operation).
- RLE2 = Locking magnet (on truck). Mechanically inhibits circuit-breaker racking-in and isolating if de-energized. (Consumption can be limited by connecting a delayed pushbutton in series so as to enable the operation).

- SFC = Pushbutton or contact for closing circuit-breaker.
- SFO = Pushbutton or contact for opening circuit-breaker.
- TB7 = Rectifier for release -MBO3.
- XDB = Terminal box of circuit-breaker circuits.
- XDB10, ... , 27 = Connectors of applications
- XDB28 = Connector of applications.

**Description of the figures**

- Fig. 1 = Circuit of motor for loading closing springs (see note C).
- Fig. 2 = Shunt closing release (anti-pumping is achieved mechanically). (see note D).
- Fig. 3 = Locking magnet. Mechanically inhibits circuit-breaker closing if de-energized. (If -RL1 is required, provide this figure when fig.31 or 32 are selected). Consumption can be limited by connecting a delayed pushbutton in series so as to enable the operation.
- Fig. 4 = Locking magnet. Mechanically inhibits circuit-breaker closing if de-energized. (If -RL1 is required, provide this figure when fig.33 or 34 are selected). Consumption can be limited by connecting a delayed pushbutton in series so as to enable the operation.
- Fig. 5 = Instantaneous undervoltage release (see note B).
- Fig. 6 = Circuit of third opening release with continuous control of winding (see note D).
- Fig. 7 = Circuit of first opening release with continuous control of winding (see note D).
- Fig. 8 = Locking magnet (on truck). Mechanically inhibits circuit-breaker racking-in and isolating if de-energized. (Consumption can be limited by connecting a delayed pushbutton in series so as to enable the operation).
- Fig. 9 = Circuit of second opening release with continuous control of winding (see note D).
- Fig. 10 = Opening solenoid for release outside circuit-breaker.
- Fig. 11 = Opening solenoid for release outside circuit-breaker with AC supply.

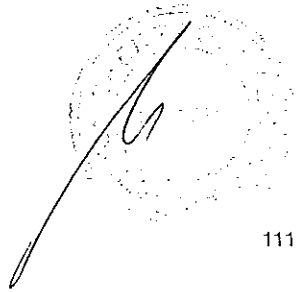
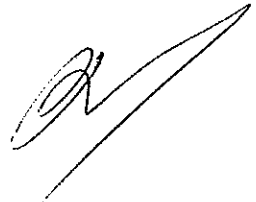

## 5. Electric circuit diagram

- Fig. 26 = Electrical signalling of closing springs loaded and discharged.
- Fig. 30 = Auxiliary let-through contact of circuit-breaker with momentary closing during circuit-breaker opening.
- Fig. 31, ... , 34 = Available auxiliary contacts of circuit-breaker (see note E).
- Fig. 51 = Contacts for electrical signalling of circuit-breaker in racked-in and isolated positions located on circuit-breaker truck (obligatory when fig. 31 or 32 are required).
- Fig. 52 = Contacts for electrical signalling of circuit-breaker in racked-in and isolated positions located on circuit-breaker truck (supplied on request when fig. 33 to 34 are required).
- Fig. 60 = Contact for electrical signalling of undervoltage release de-energized.

### Incompatibility

The circuits indicated in the following figures cannot be supplied at the same time in the same circuit-breaker:

3-4	3-33-34	4-31-32	5-6	10-11
31-32-33-34	31-32-52	33-34-51	51-52	

### Notes

- A) Circuit-breaker is equipped solely with the applications specified in the order confirmation. Consult this catalogue for information about how to make out an order.
- B) The undervoltage release can be supplied for energizing with voltage derived from the supply side of the circuit-breaker or from an independent source. Circuit-breaker closing is only allowed when the release is energized (closing lock is obtained mechanically). If there is the same power supply for the shunt closing and under-voltage releases and the circuit-breaker must close automatically when auxiliary voltage returns, there must be a 50 ms delay between the under-voltage release's enabling instant and energizing of the shunt closing release.  
Incompatible with -MBO4.
- C) Check power of auxiliary circuit to find out whether several motors for loading the closing springs can be operated at the same time. To prevent excessive power draw, the springs must be loaded by hand before auxiliary circuit is powered.
- D) The circuit for monitoring the continuity of the release windings must only be used for that purpose. The SOR Test Unit can be used for checking the continuity of the various different releases:  
-MBO4 incompatible with -MBU.  
-MBO4 not available on Vmax and VD4 50kA.
- E) When fig. 6 is required, contact -BGB1 (23-24) of fig. 32-34 is not available.  
When fig. 7 is required, contact -BGB1 (3-4) of fig. 31-32-33-34 is not available.  
When fig. 9 is required, contact -BGB1 (7-8) of fig. 31-32-33-34 is not available.  
When fig. 10 or 11 are required, contact -BGB1 (31-32) of fig. 32 and 34 is not available.  
When fig. 30 is required, contact -BGB1 (25-26) of fig. 32 and 34 is not available.
- F) The contacts for electrical signalling of circuit-breaker in isolated and racked-in position (-BGT1 and BGT2) shown in fig. 51-52 are installed on circuit-breaker truck (movable part).
- G) Fig. 3 is supplied when fig. 31 or 32 are required.  
Fig. 4 is supplied when fig. 33 or 34 are required (in this case, it is obligatory to supply -BGT3).
- H) Fig. 10 is only available for VD4 up to 31.5 kA and Vmax.  
Fig. 11 is only available for VD4 up to 31.5 kA.
- I) The energizing voltage must be the same for both signals.



Electric circuit diagram of withdrawable circuit-breakers 36 kV 1VCD 400237

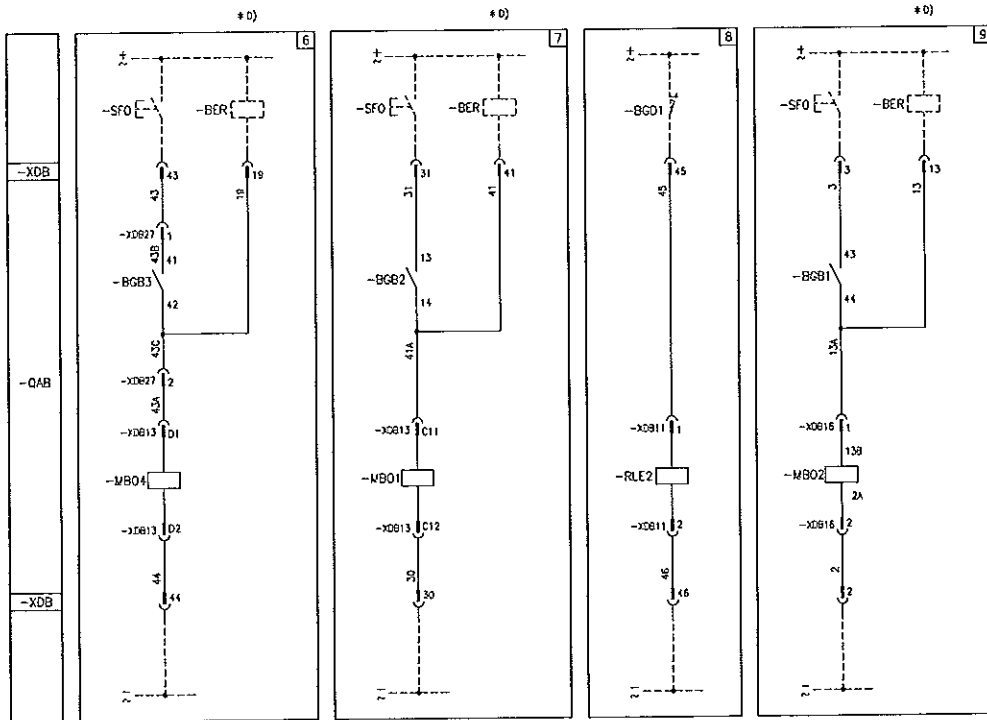
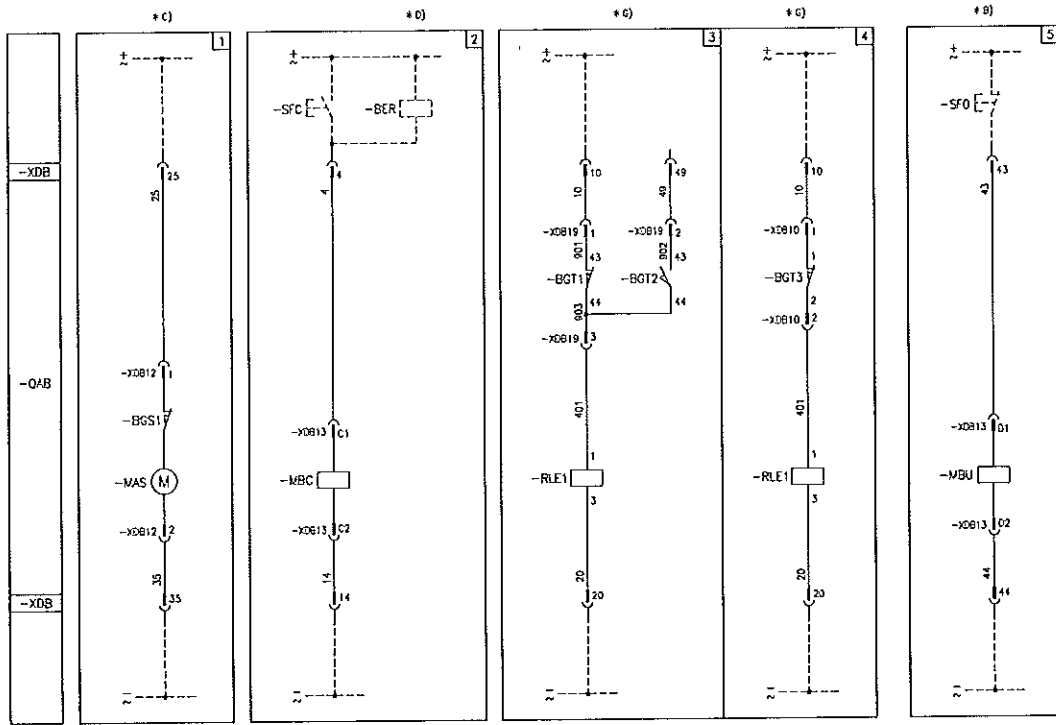



*[Handwritten signature]*

*[Handwritten signature]*

+E) +F)

32

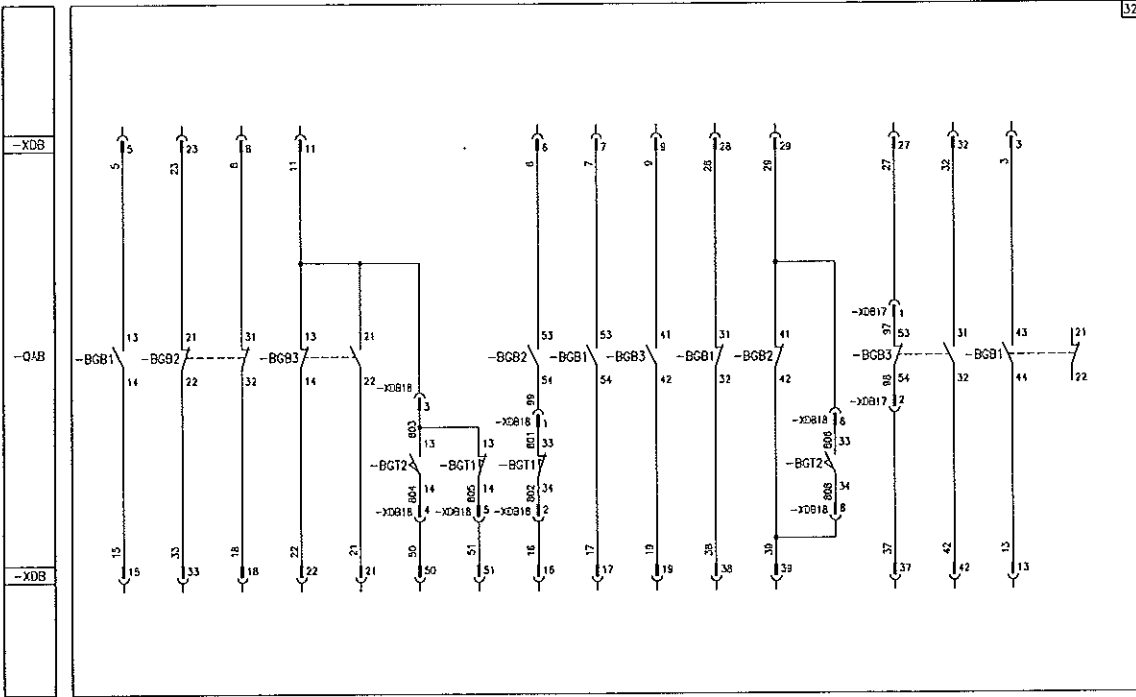

+E)

33

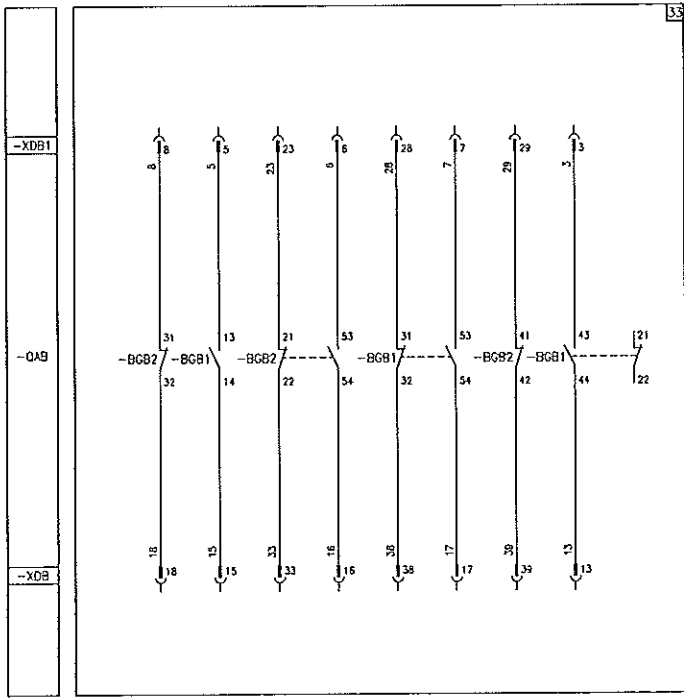

*[Handwritten signature]*

*[Handwritten signature]*

# 5. Electric circuit diagram

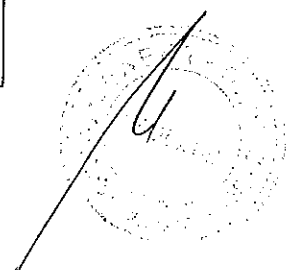
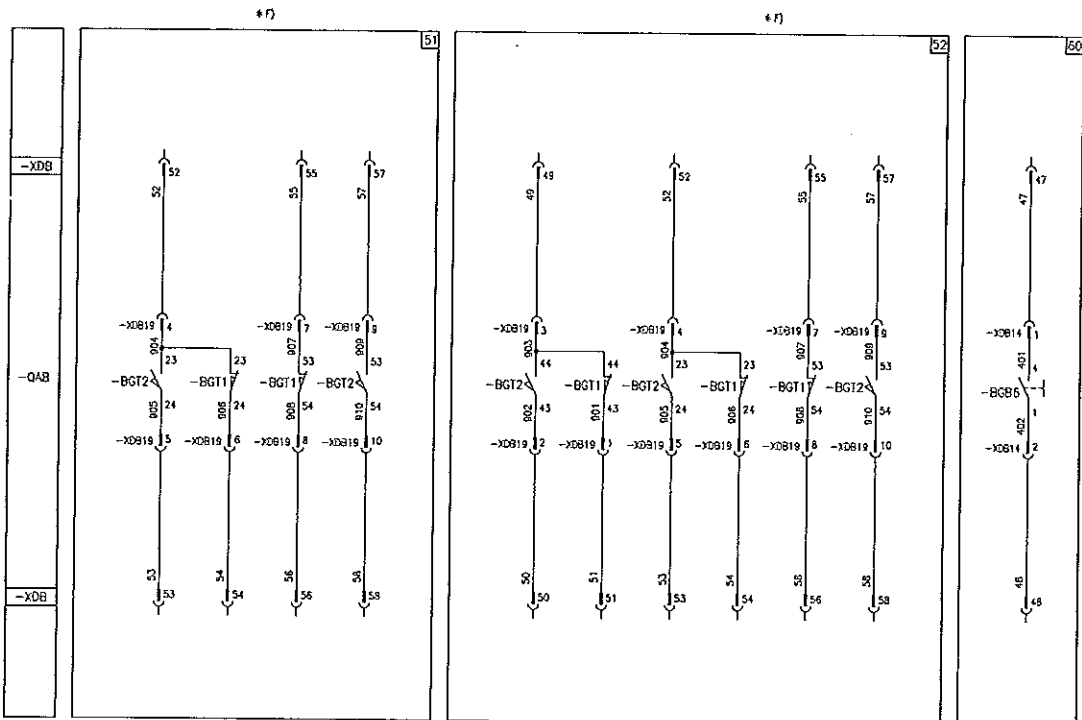
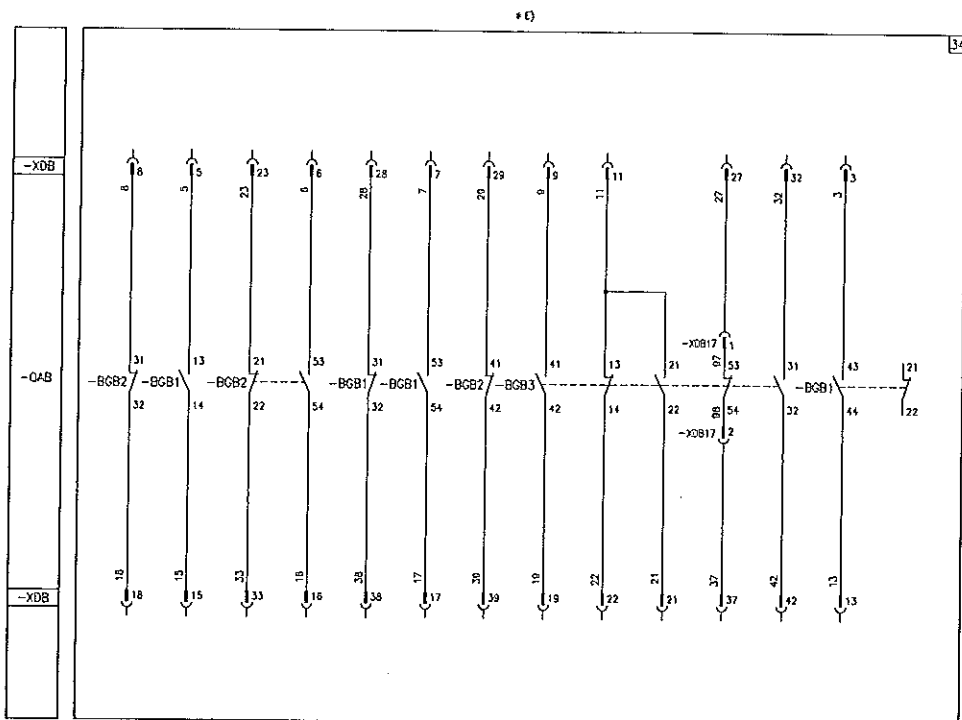
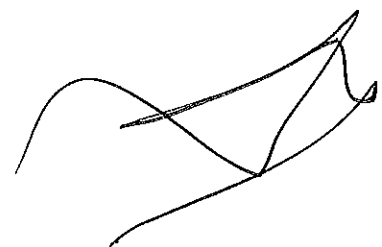
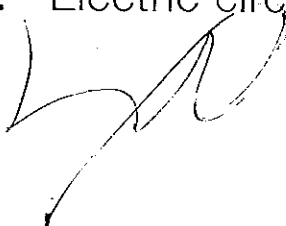

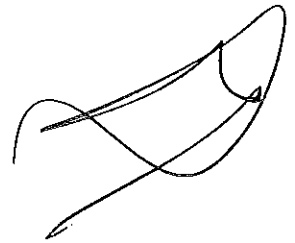

**Caption**

- = Figure number of the diagram.
- \* = See note indicated by the letter.
- BER = SOR Test Unit device for monitoring continuity of shunt opening and closing release winding (see note D)
- BGB1, ... ,3 = Auxiliary contacts of circuit-breaker.
- BGB4 = Auxiliary let-through contact of circuit-breaker with momentary closing during circuit-breaker opening.
- BGB6 = Contact for electrical signalling of undervoltage release de-energized.
- BGB11 = Contact for cutting off electrical signal -BGB4 if opening operation is performed in the manual mode.
- BGD1 = Enclosure door position contact.
- BGS1 = Limit contact of spring loading motor.
- BGS2 = Contact for signalling closing springs loaded-discharged.
- BGT1 = Electrical signalling contacts for circuit-breaker in racked-in position (see note F).
- BGT2 = Contacts for electrical signalling of circuit-breaker in isolated position (see note F).
- BGT3 = Circuit-breaker position contact, open during isolating travel.
- MAS = Motor for loading closing springs (see note C).
- MBC = Shunt closing release (see note D).
- MBO1 = First shunt opening release (see note D).
- MBO2 = Second shunt opening release (see note D).
- MBO3 = Opening solenoid for release outside circuit-breaker.
- MBO4 = Third shunt opening release (see note D).
- MBU = Under-voltage release (see note B).
- QAB = Circuit-breaker applications.
- RLE1 = Locking magnet. Mechanically inhibits circuit-breaker closing if de-energized. (Consumption can be limited by connecting a delayed operation enabling pushbutton in series).

- RLE2 = Locking magnet (on truck). Mechanically inhibits circuit-breaker racking-in and isolating if de-energized. (Consumption can be limited by connecting a delayed pushbutton in series so as to enable the operation).
- SFC = Pushbutton or contact for closing circuit-breaker.
- SFO = Pushbutton or contact for opening circuit-breaker.
- TB7 = Rectifier for release -MBO3.
- XDB = Terminal box of circuit-breaker circuits.
- XDB10, ... , 27 = Connectors of applications.
- XDB28 = Connector of applications.

**Description of the figures**

- Fig. 1 = Circuit of motor for loading closing springs (see note C).
- Fig. 2 = Shunt closing release (anti-pumping is achieved mechanically), (see note D).
- Fig. 3 = Locking magnet. Mechanically inhibits circuit-breaker closing if de-energized. (If -RL1 is required, provide this figure when fig. 31 or 32 are selected). Consumption can be limited by connecting a delayed pushbutton in series so as to enable the operation.
- Fig. 4 = Locking magnet. Mechanically inhibits circuit-breaker closing if de-energized. (If -RL1 is required, provide this figure when fig.33 or 34 are selected). Consumption can be limited by connecting a delayed pushbutton in series so as to enable the operation.
- Fig. 5 = Instantaneous undervoltage release (see note B).
- Fig. 6 = Circuit of third opening release with continuous control of winding (see note D).
- Fig. 7 = Circuit of first opening release with continuous control of winding (see note D).



## 5. Electric circuit diagram

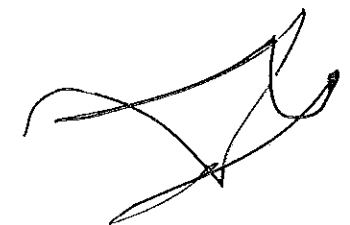
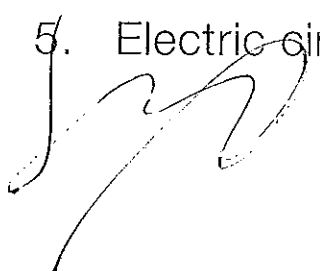

- Fig. 8 = Locking magnet (on truck). Mechanically inhibits circuit-breaker racking-in and isolating if de-energized. (Consumption can be limited by connecting a delayed pushbutton in series so as to enable the operation).
- Fig. 9 = Circuit of second opening release with continuous control of winding (see note D).
- Fig. 10 = Opening solenoid for release outside circuit-breaker.
- Fig. 11 = Opening solenoid for release outside circuit-breaker with AC supply.
- Fig. 26 = Electrical signalling of closing springs loaded and discharged.
- Fig. 30 = Auxiliary let-through contact of circuit-breaker with momentary closing during circuit-breaker opening.
- Fig. 31, ... , 34 = Available auxiliary contacts of circuit-breaker (see note E).
- Fig. 51 = Contacts for electrical signalling of circuit-breaker in racked-in and isolated positions located on circuit-breaker truck (obligatory when fig.31 or 32 are required).
- Fig. 52 = Contacts for electrical signalling of circuit-breaker in racked-in and isolated positions located on circuit-breaker truck (supplied on request when fig.33 to 34 are required).
- Fig. 60 = Contact for electrical signalling of undervoltage release de-energized.

### Notes

- A) The circuit-breaker is equipped solely with the applications specified in the order confirmation. Consult this catalogue for information about how to make out an order.
- B) The undervoltage release can be supplied for energizing with voltage derived from the supply side of the circuit-breaker or from an independent source. Circuit-breaker closing is only allowed when the release is energized (closing lock is obtained mechanically). If there is the same power supply for the shunt closing and under-voltage releases and the circuit-breaker must close automatically when auxiliary voltage returns, there must be a 50 ms delay between the under-voltage release's enabling instant and energizing of the shunt closing release.  
Incompatible with -MBO4.
- C) Check power of auxiliary circuit to find out whether several motors for loading the closing springs can be operated at the same time. To prevent excessive power draw, springs must be loaded by hand before auxiliary circuit is powered.
- D) The circuit for monitoring the continuity of the release windings must only be used for that purpose. The SOR Test Unit can be used for checking the continuity of the various different releases.  
-MBO4 incompatible with -MBU.
- E) When fig. 6 is required, contact -BGB3 (41-42) of fig. 32-34 is not available.  
When fig. 9 is required, contact -BGB1 (43-44) of fig. 31-32-33-34 is not available.  
When fig. 10 or 11 are required, contact -BGB3 (31-32) of fig. 32 and 34 is not available.  
When fig. 30 is required, contact -BGB3 (53-54) of fig. 32 and 34 is not available.
- F) The contacts for electrical signalling of circuit-breaker in racked-in and isolated positions (-BGT1 and -BGT2) shown in fig. 51-52 are located on circuit-breaker truck (moving part).
- G) Fig. 3 is supplied when fig. 31 or 32 are required. Fig. 4 is supplied when fig. 33 or 34 are required (in this case, it is obligatory for -BGT3 to be supplied).
- H) Fig. 10 is only available for VD4 up to 31.5 kA. Fig. 11 is only available for VD4 up to 31.5 kA.
- I) The energizing voltage must be the same for both signals.

### Incompatibility

The circuits indicated in the following figures cannot be supplied at the same time in the same circuit-breaker:

3-4	3-33-34	4-31-32	5-6	10-11
31-32-33-34	31-32-52	33-34-51	51-52	

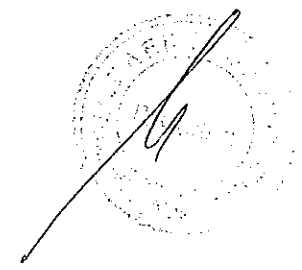
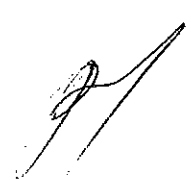

Handwritten signature or mark.

Handwritten signature or mark.

(

(

Handwritten signature or mark.

Handwritten signature or mark.

(

(

---



Contact us

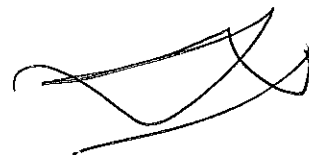

**ABB S.p.A.**  
**Electrification Products Division**  
**Medium Voltage Products**  
Via Friuli, 4  
I-24044 Dalmine  
Tel.: +39 035 6952 111  
Fax: +39 035 6952 874  
E-mail: info.mv@it.abb.com

The data and illustrations are not binding. We reserve the right to make changes without notice in the course of technical development of the product.

© Copyright 2016 ABB. All rights reserved.

**ABB AG <sup>(1)</sup>**  
**Alor Emag Medium Voltage Products**  
Oberhausener Strasse 33      Petzower Strasse 8  
D-40472 Ratingen              D-14542 Glindow  
Phone: +49(0)2102/12-1230  
Fax: +49(0)2102/12-1916  
E-mail: powertech@de.abb.com

[www.abb.com](http://www.abb.com)

1VCP000001 - Rev. V, en - Technical catalogue - 2016.04 (VD4-50 kA) (gs)



Power and productivity  
for a better world™





Приложение 1.1 помощен  
документ\_MA\_VD4-36kV-  
50KA(EN)Y\_647654-1403

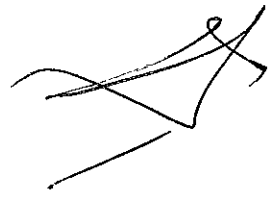

Medium voltage products

# Installation and service instructions

## 12 ... 36 kV - 630 ... 3150 A - 16 ... 50 kA

### Index

For your safety!	1
I. Introduction	2
II. Environmental protection programme	2
1. Packing and transport	3
2. Checking on receipt	4
3. Storage	5
4. Handling	6
5. Description	7
6. Instructions for operating the circuit-breaker	48
7. Installation	52
8. Putting into service	59
9. Maintenance	61
10. Application of the X-ray emission Standards	65
11. Spare parts and accessories	66
12. Electric circuit diagrams	67
13. Overall dimensions	68
14. Product quality and environmental protection	95

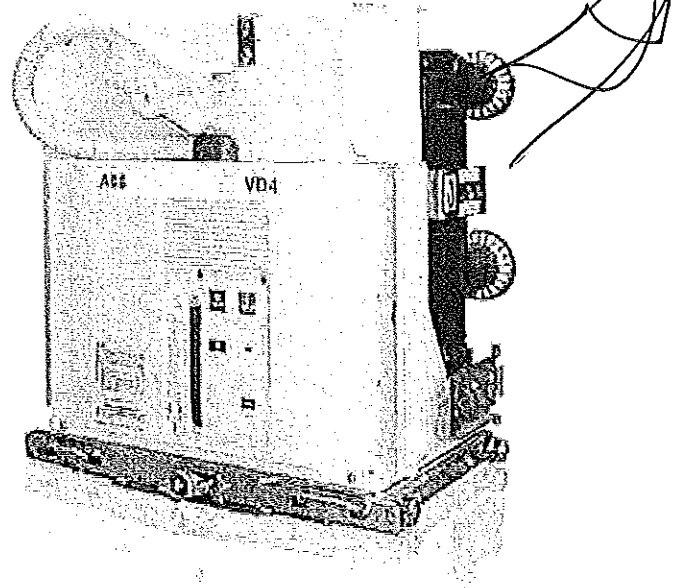

Power and productivity  
for a better world™

**ABB**

## For your safety!

- Make sure that the installation room (spaces, divisions and ambient) is suitable for the electrical apparatus.
- Check that all the installation, putting into service and maintenance operations are carried out by qualified personnel with suitable knowledge of the apparatus.
- Make sure that the standard and legal prescriptions are complied with during installation, putting into service and maintenance, so that installations according to the rules of good working practice and safety in the work place are constructed.
- Strictly follow the information given in this instruction manual.
- Check that the rated performance of the apparatus is not exceeded during service.
- Check that the personnel operating the apparatus have this instruction manual to hand as well as the necessary information for correct intervention.
- Pay special attention to the danger notes indicated in the manual by the following symbol:



Responsible behaviour safeguards  
your own and others' safety!

For any requests, please contact the  
ABB Assistance Service.

## I. Introduction

This publication contains the information needed to install medium voltage VD4 circuit-breakers and put them into service.

For correct use of the product, please read it carefully. Like all the apparatus we manufacture, the VD4 circuit-breakers are designed for different installation configurations. However, this apparatus allows further technical-construction modifications (at the customer's request) to adapt to special installation requirements.

Consequently, the information given below may sometimes not contain instructions concerning special configurations. Apart from this manual, it is therefore always necessary to consult the latest technical documentation (electric circuit and wiring diagrams, assembly and installation drawings, any protection coordination studies, etc.), especially regarding any variants requested in relation to the standardised configurations.

Only use original spare parts for maintenance operations. For further information, please also see the technical catalogue of the circuit-breaker and the spare parts catalogue.

 **All the installation, putting into service, running and maintenance operations must be carried out by skilled personnel with in-depth knowledge of the apparatus.**

## II. Environmental protection programme

The VD4 circuit-breakers are manufactured in accordance with the ISO 14000 Standards (Guidelines for environmental management).

The production processes are carried out in compliance with the Standards for environmental protection in terms of reduction in energy consumption as well as in raw materials and production of waste materials. All this is thanks to the medium voltage apparatus manufacturing facility environmental management system.

# 1. Packing and transport

The circuit-breaker is shipped in special packing, in the open position and with the spring discharged.  
Each piece of apparatus is protected by a plastic cover to prevent any infiltration of water during the loading and unloading stages and to keep the dust off during storage.

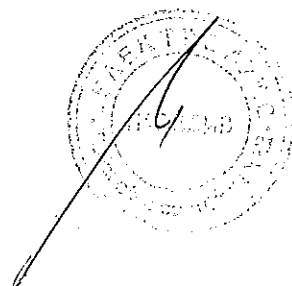
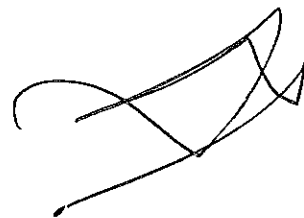

## 2. Checking on receipt



Before carrying out any operation, always make sure that the operating mechanism spring is discharged and that the apparatus is in the open position.

On receipt, check the state of the apparatus, integrity of the packing and correspondence with the nameplate data (see fig. 1) with what is specified in the order confirmation and in the accompanying shipping note.

Also make sure that all the materials described in the shipping note are included in the supply.

Should any damage or irregularity be noted in the supply on unpacking, notify ABB (directly or through the agent or supplier) as soon as possible and in any case within five days of receipt.

The apparatus is only supplied with the accessories specified at the time of ordering and validated in the order confirmation sent by ABB.

The accompanying documents inserted in the shipping packing are:

- instruction manual (this document)
- test certification
- identification label
- copy of the shipping documents
- electric wiring diagram.

Other documents which are sent prior to shipment of the apparatus are:

- order confirmation
- original shipping advice note
- any drawings or documents referring to special configurations/conditions.

<b>ABB</b>			
1	CIRCUIT-BREAKER	IEC 62271-100	2
	VD4 ... ..	CEI 17-1	
3	CLASSIFICATION ... ..		
	SN ... ..	PR. YEAR .....	
	M MASS ... kV		
	Ur		
4	ELECTRIC DIAGRAM ... ..		
	FIG. ... ..		
B	OPERATING MECHANISM		
5	-MO1 ... .. V		
	Made by ABB		

### Caption

- A Circuit-breaker rating plate
- B Operating mechanism rating plate
- 1 Type of apparatus
- 2 Symbols of compliance with Standards
- 3 Serial number
- 4 Circuit-breaker characteristics
- 5 Characteristics of the operating mechanism auxiliaries

Fig. 1

### 3. Storage

When a period of storage is foreseen, our workshops can (on request) provide suitable packing for the specified storage conditions.

On receipt the apparatus must be carefully unpacked and checked as described in Checking on receipt (chap. 2).

If immediate installation is not possible, the packing must be replaced, using the original material supplied.

Insert packets of special hygroscopic substances inside the packing, with at least one standard packet for piece of apparatus.

Should the original packing not be available and immediate installation is not possible, store in a covered, well-ventilated, dry, dust-free, non-corrosive ambient, away from any easily flammable materials and at a temperature between  $-5\text{ }^{\circ}\text{C}$  and  $+45\text{ }^{\circ}\text{C}$ .

In any case, avoid any accidental impacts or positioning which stresses the structure of the apparatus.

